

Off-centre (107mm) Product Inlet Models - Single Grade

TW1 Dispenser - SF and HF

Dispenser Models

8752KXTW1	9152KXTW1
8753KXTW1	9153KXTW1
8852KXTW1	9852KXTW1
8853KXTW1	9853KXTW1

TW1 Self-contained Pump - SF and HF

Dispenser Models

8752KTW1
8852KTW1
9152KTW1
9852KTW1

Central Product Inlet Models

Self-contained Pump - Twin Inlet Manifold

Dispenser Models

8753KTW1M
8853KTW1M
9153KTW1M
9853KTW1M

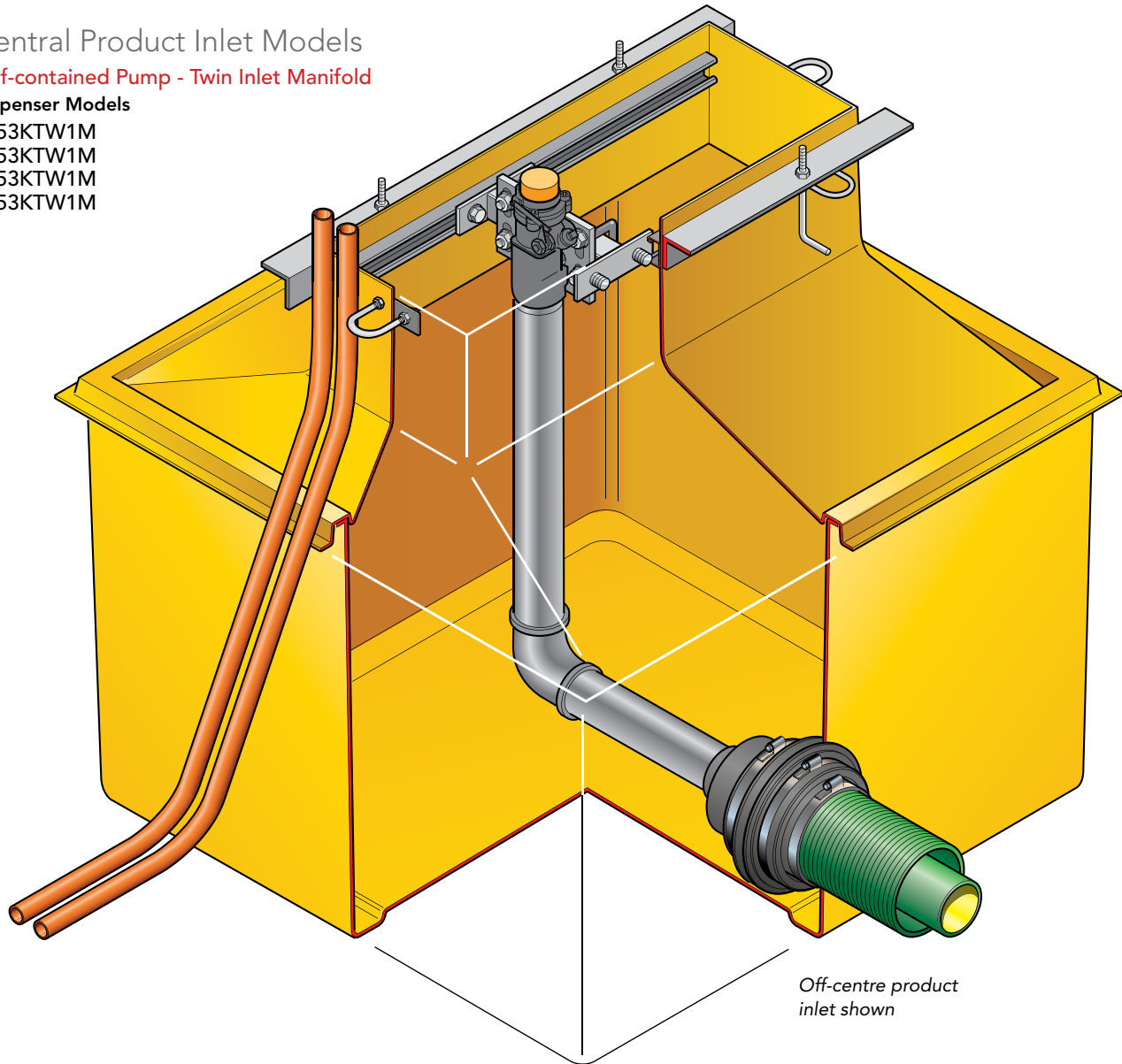

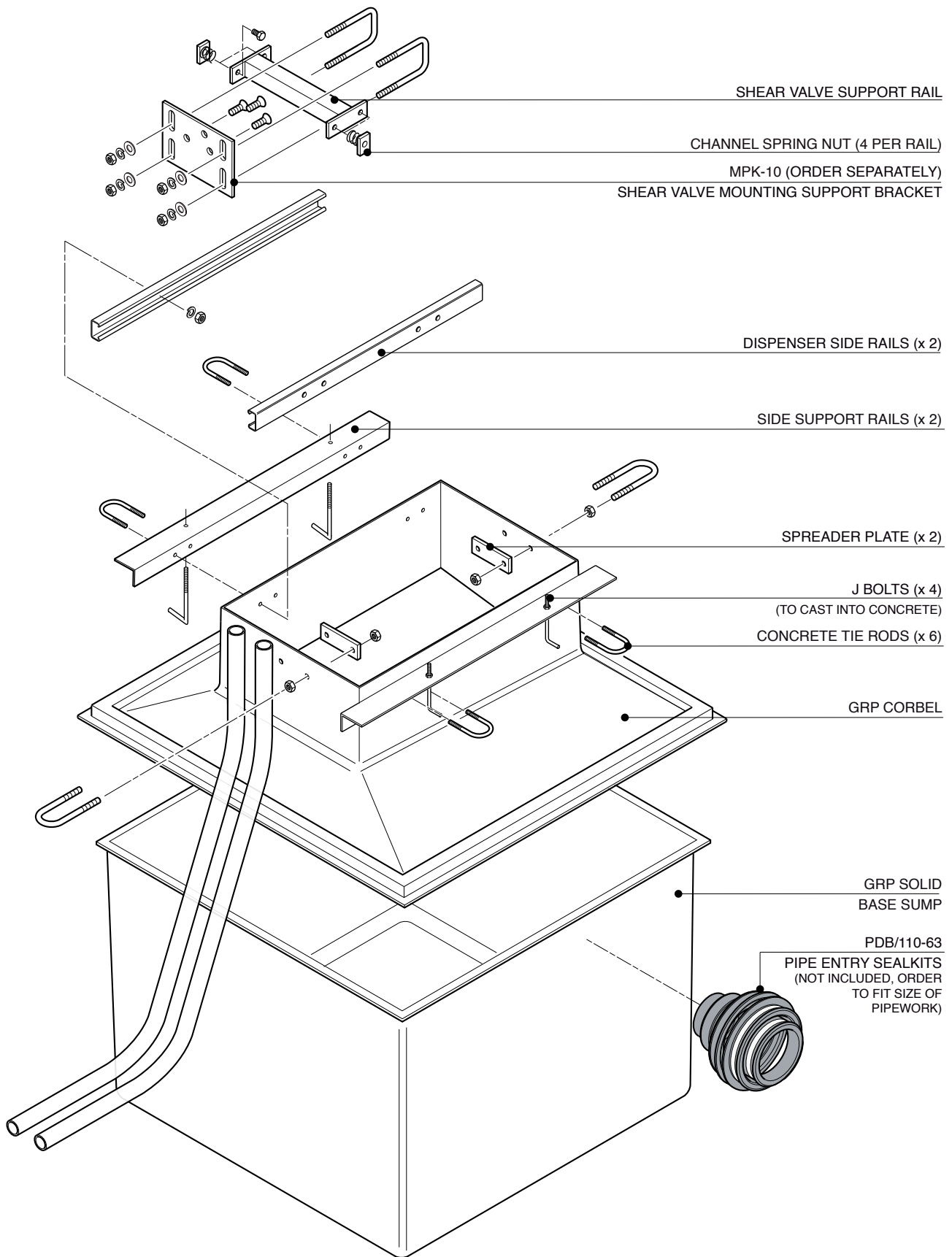

682 x 682 x 652mm deep dispenser sump and corbel to fit Gasboy TW1 dispenser models. Includes dispenser support rails, 1 shear valve rail and all fixings.

For reference purposes only. This drawing is not a specification. Order against product code only. To enable continuous improvement of our products, the designs and specifications are subject to change without notice.

Off-centre (107mm) Product Inlet Models - Single Grade

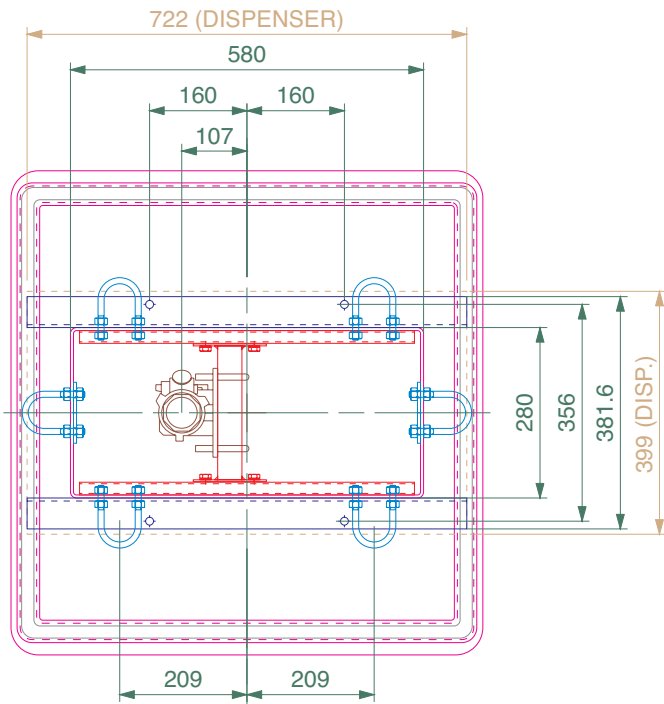

TW1 Dispenser - SF and HF

Dispenser Models

8752KXTW1	9152KXTW1
8753KXTW1	9153KXTW1
8852KXTW1	9852KXTW1
8853KXTW1	9853KXTW1

TW1 Self-contained Pump - SF and HF

Dispenser Models

8752KTW1
8852KTW1
9152KTW1
9852KTW1

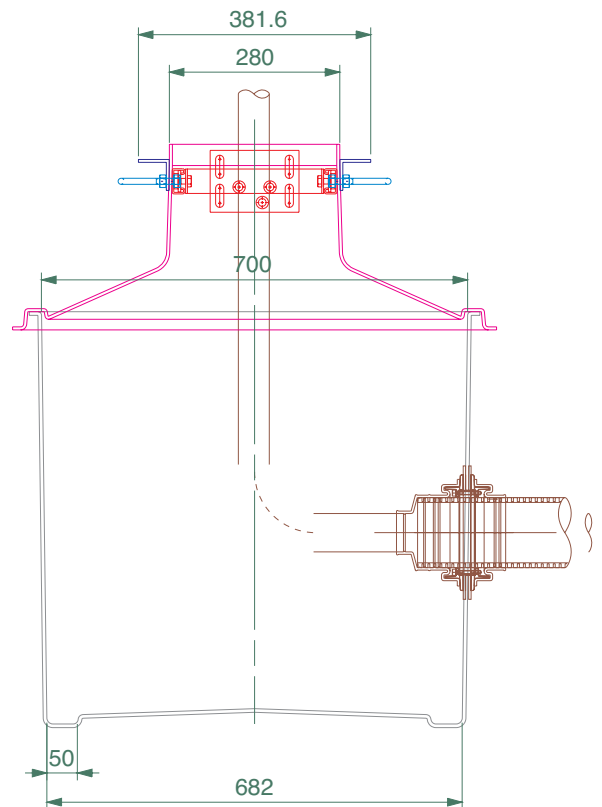
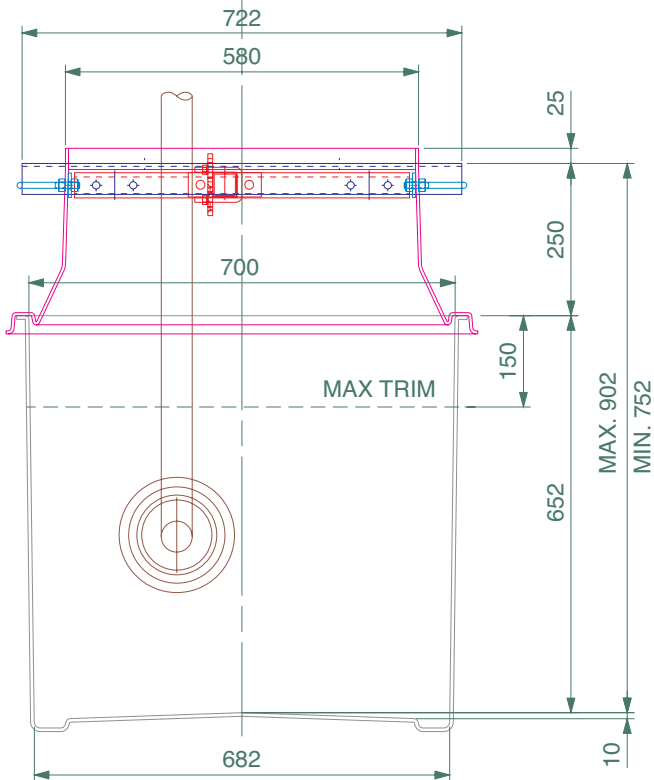

682 x 682 x 652mm deep dispenser sump and corbel to fit Gasboy TW1 dispenser models. Includes dispenser support rails, 1 shear valve rail and all fixings.

For reference purposes only. This drawing is not a specification. Order against product code only. To enable continuous improvement of our products, the designs and specifications are subject to change without notice.

FIBRELITE 
PART OF OPW A DOVER COMPANY

Central Product Inlet Models

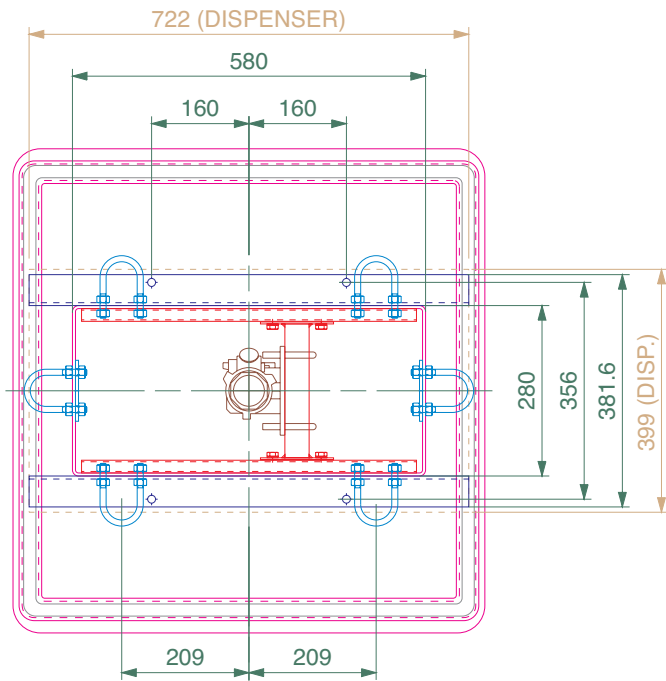

Self-contained Pump - Twin Inlet Manifold

Dispenser Models

- 8753KTW1M
- 8853KTW1M
- 9153KTW1M
- 9853KTW1M

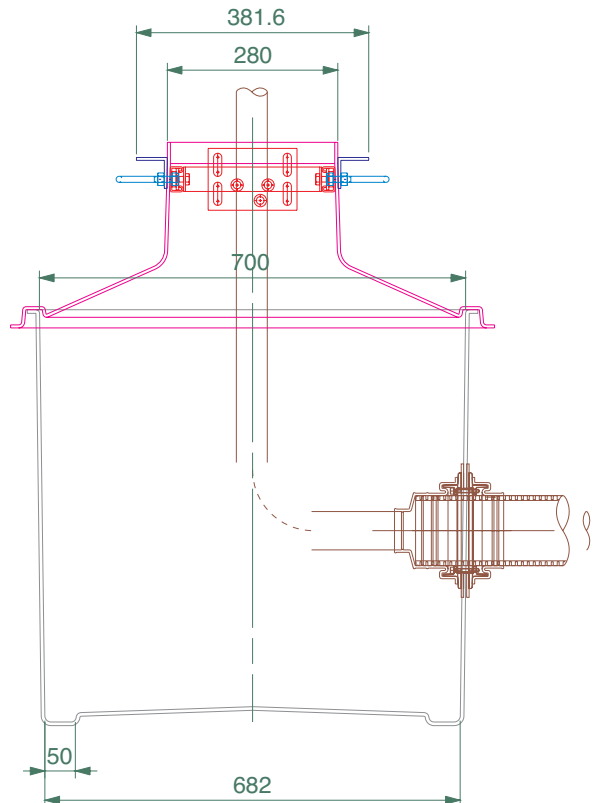
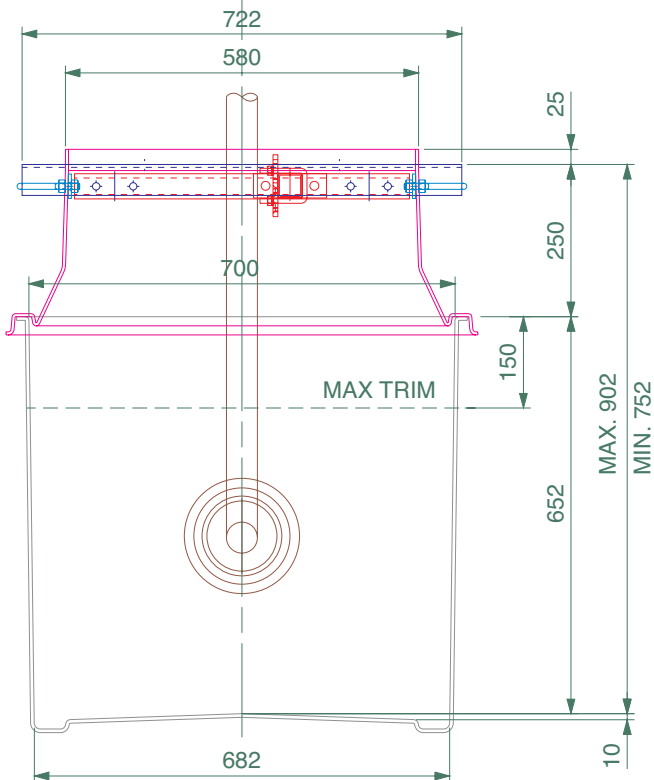

682 x 682 x 652mm deep dispenser sump and corbel to fit Gasboy TW1 dispenser models. Includes dispenser support rails, 1 shear valve rail and all fixings.

For reference purposes only. This drawing is not a specification. Order against product code only. To enable continuous improvement of our products, the designs and specifications are subject to change without notice.

FIBRELITE 
PART OF OPW A DOVER COMPANY