

862mm x 862mm GRP solid base sump and corbel to fit Wayne HELIX dispenser model. Includes dispenser support rails, 2 shear valve rails and all fixings.

For reference purposes only. This drawing is not a specification. Order against product code only. To enable continuous improvement of our products, the designs and specifications are subject to change without notice.

FIBRELITE 
PART OF OPW A DOVER COMPANY

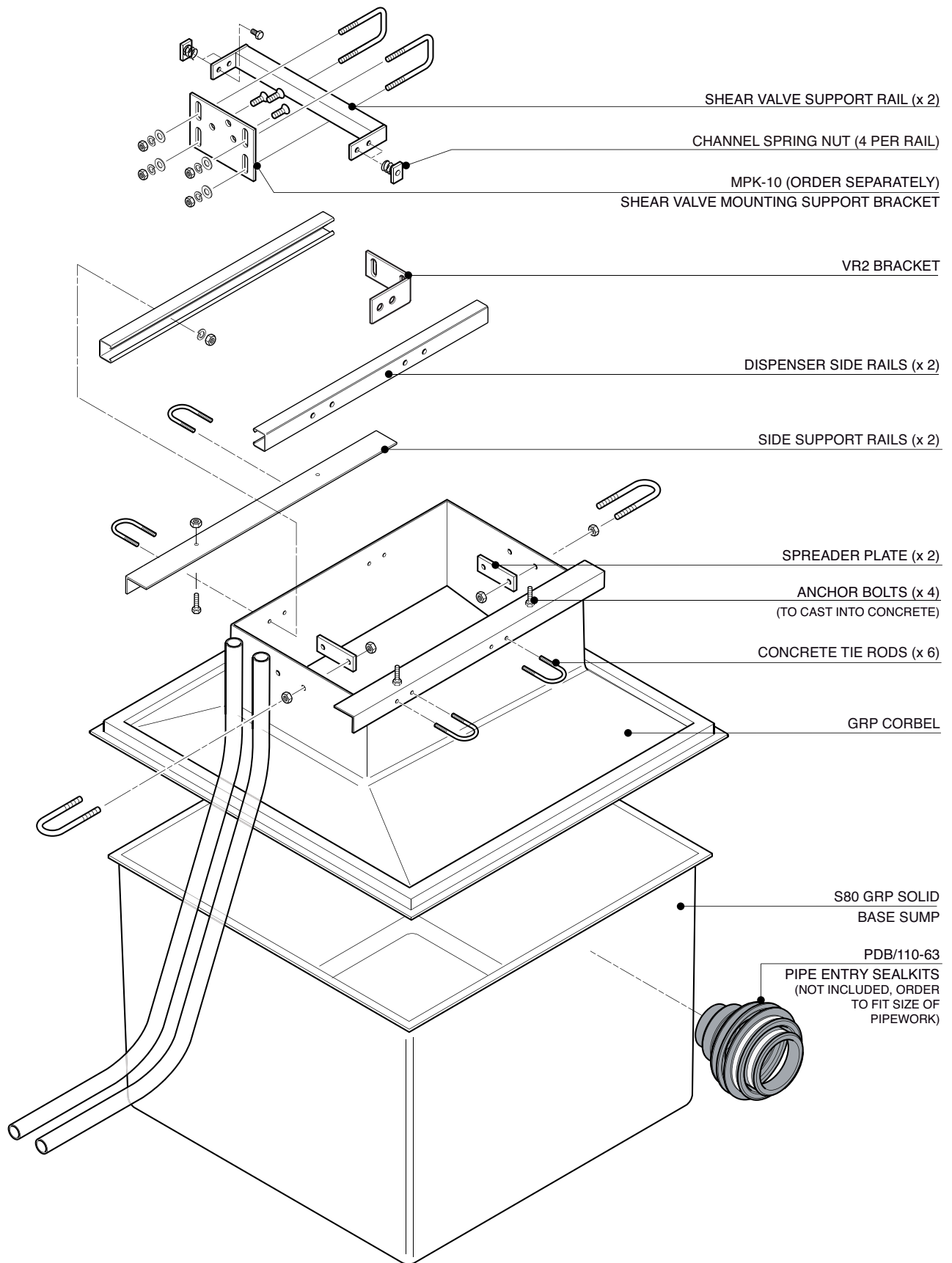

862mm x 862mm GRP solid base sump and corbel to fit Wayne HELIX dispenser model. Includes dispenser support rails, 2 shear valve rails and all fixings.

For reference purposes only. This drawing is not a specification. Order against product code only. To enable continuous improvement of our products, the designs and specifications are subject to change without notice.

FIBRELITE 
PART OF OPW A DOWDER COMPANY

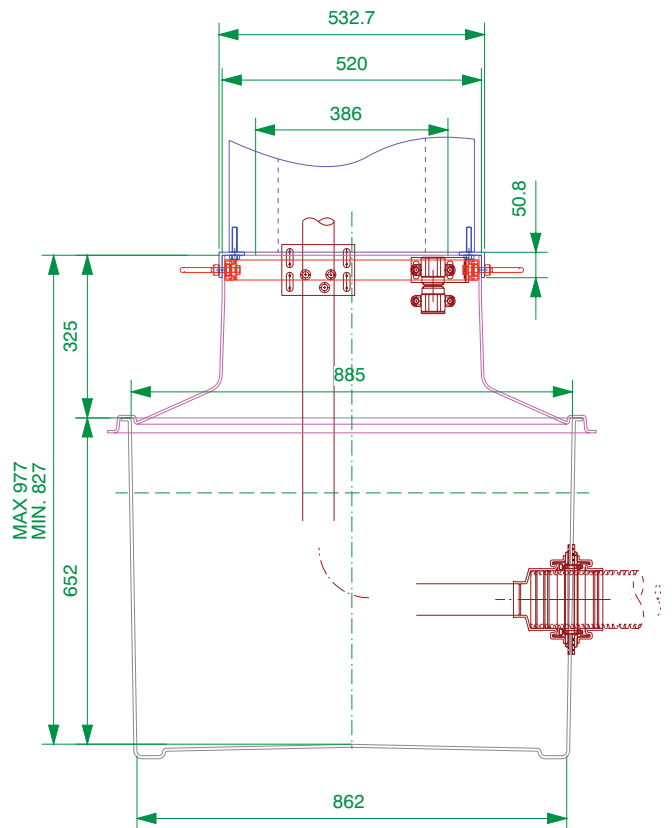
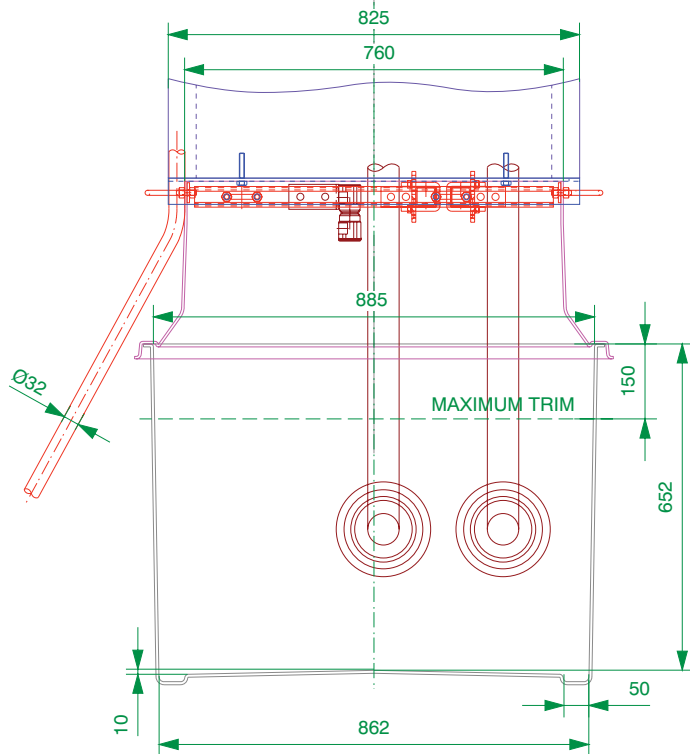
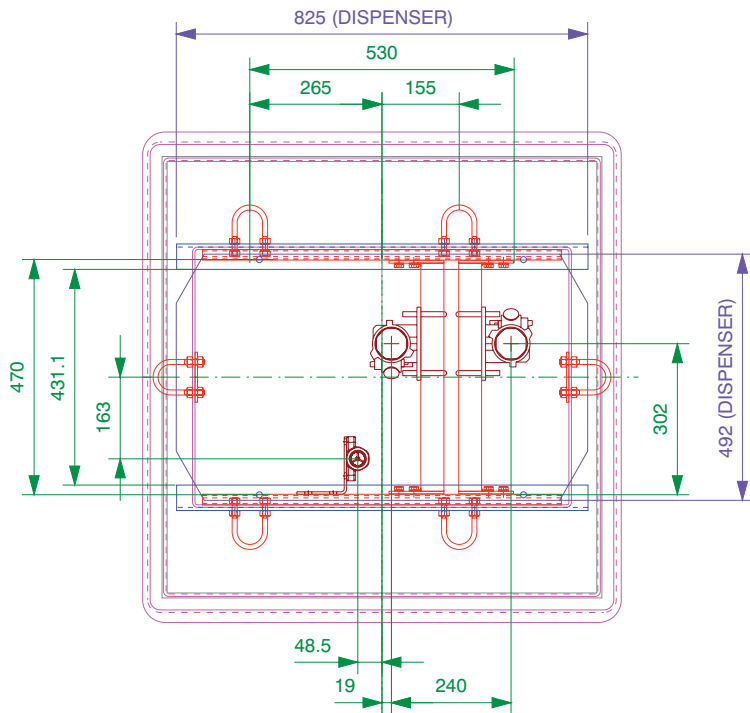

862mm x 862mm GRP solid base sump and corbel to fit Wayne HELIX dispenser model. Includes dispenser support rails, 2 shear valve rails and all fixings.

For reference purposes only. This drawing is not a specification. Order against product code only. To enable continuous improvement of our products, the designs and specifications are subject to change without notice.

FIBRELITE 
PART OF OPW A DOVER COMPANY