

45" diameter sump to fit 42" tank collar ring with corbel, internal lid, adjustable skirt and round 36" flat sealed cover.

For reference purposes only. This drawing is not a specification. Order against product code only. To enable continuous improvement of our products, the designs and specifications are subject to change without notice.

**FIBRELITE**   
PART OF OPW A DOVER COMPANY

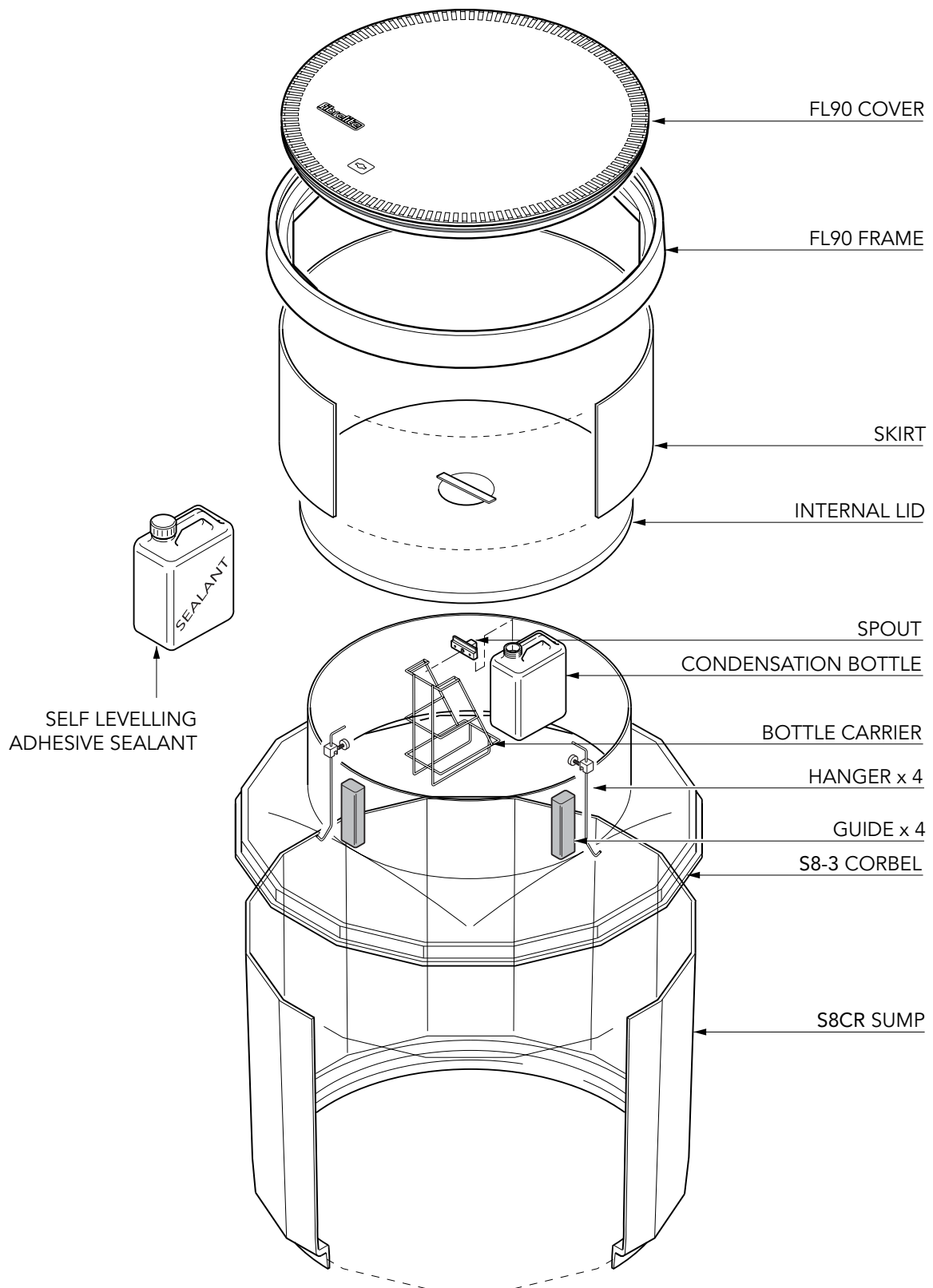

45" diameter sump to fit 42" tank collar ring with corbel, internal lid, adjustable skirt and round 36" flat sealed cover.

For reference purposes only. This drawing is not a specification. Order against product code only. To enable continuous improvement of our products, the designs and specifications are subject to change without notice.

**FIBRELITE**   
 PART OF OPW A DOVER COMPANY

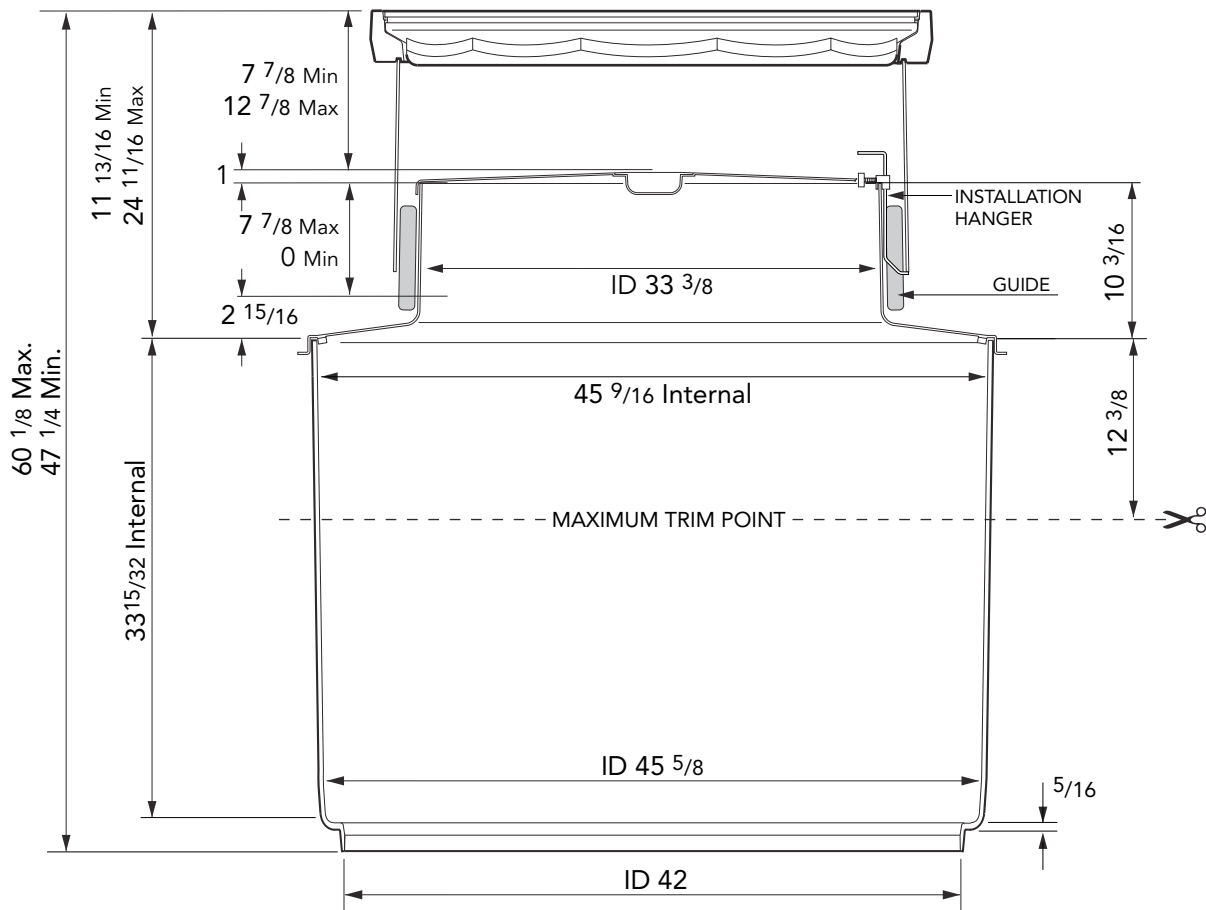
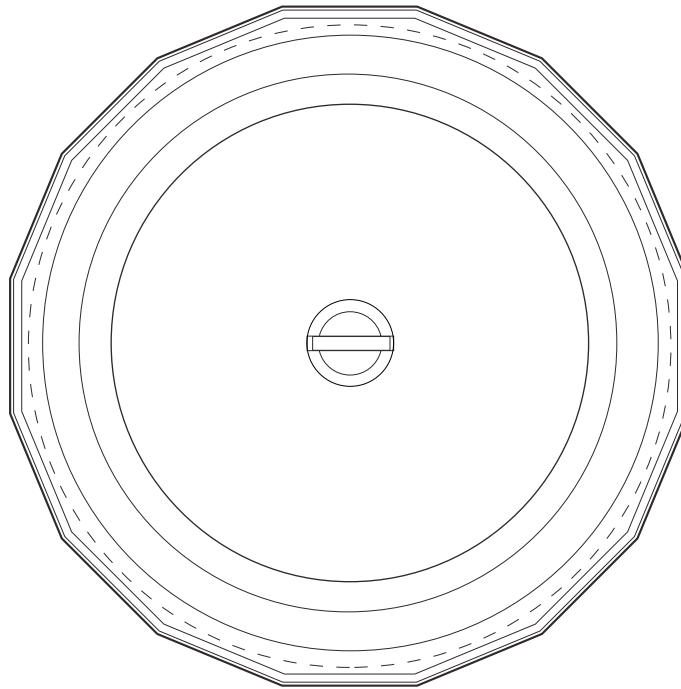

45" diameter sump to fit 42" tank collar ring with corbel, internal lid, adjustable skirt and round 36" flat sealed cover.

For reference purposes only. This drawing is not a specification. Order against product code only. To enable continuous improvement of our products, the designs and specifications are subject to change without notice.

**FIBRELITE**   
 PART OF OPW A DOVER COMPANY

**VERY IMPORTANT**  
 OUTER EDGE "A" OF FRAME SET  $\frac{1}{4}$  -  $\frac{1}{2}$ "  
 ABOVE GENERAL GRADE AREA WITH  
 CONCRETE RAMPED AWAY OVER 12".

**TYPICAL INSTALLATION**

**CONCRETE**

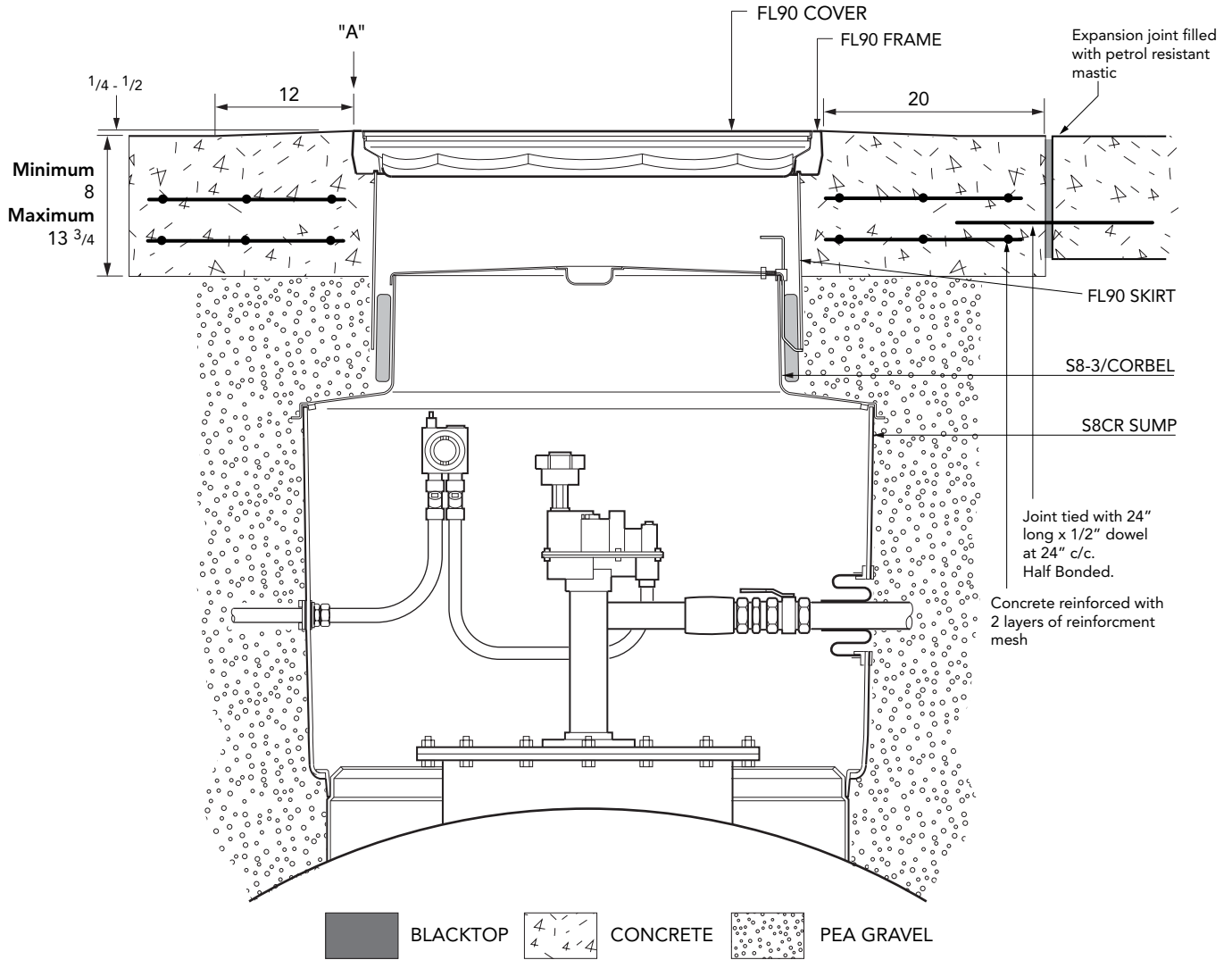

**ALTERNATIVE INSTALLATION ADVICE**

**BLACKTOP**

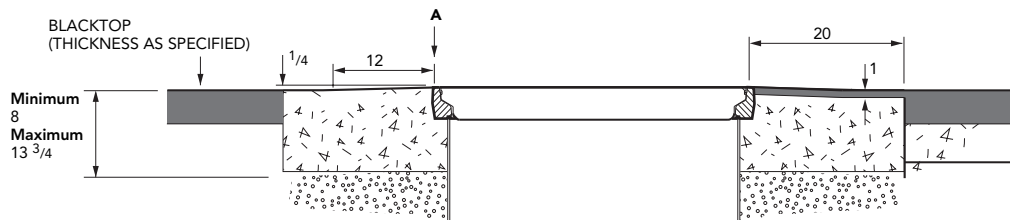

45" diameter sump to fit 42" tank collar ring with corbel, internal lid, adjustable skirt and round 36" flat sealed cover.

For reference purposes only. This drawing is not a specification. Order against product code only. To enable continuous improvement of our products, the designs and specifications are subject to change without notice.

**FIBRELITE**   
 PART OF OPW A DOVER COMPANY