

300mm diameter watertight flat sealed cover with composite frame. Temperature and chemical resistant. Designed for steam applications.

For reference purposes only. This drawing is not a specification. Order against product code only. To enable continuous improvement of our products, the designs and specifications are subject to change without notice.

FIBRELITE 
PART OF OPW A DOVER COMPANY

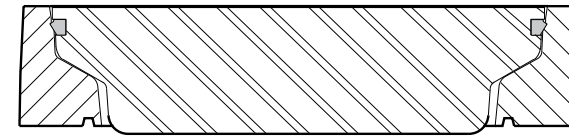
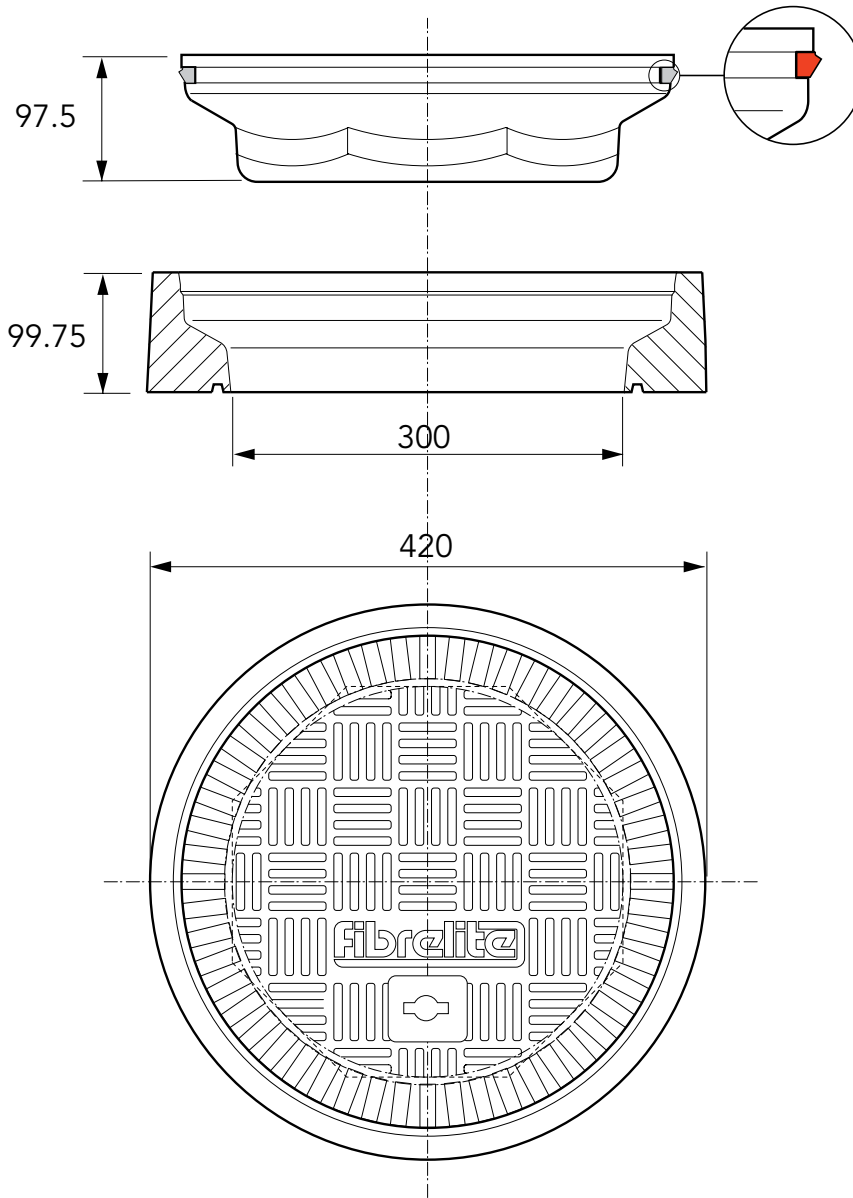

Load Rating	Cover Weight	Frame Weight
C250	7 kg	3 kg

300mm diameter watertight flat sealed cover with composite frame. Temperature and chemical resistant. Designed for steam applications.

For reference purposes only. This drawing is not a specification. Order against product code only. To enable continuous improvement of our products, the designs and specifications are subject to change without notice.

FIBRELITE 
PART OF OPW A DOVER COMPANY

CONCRETE

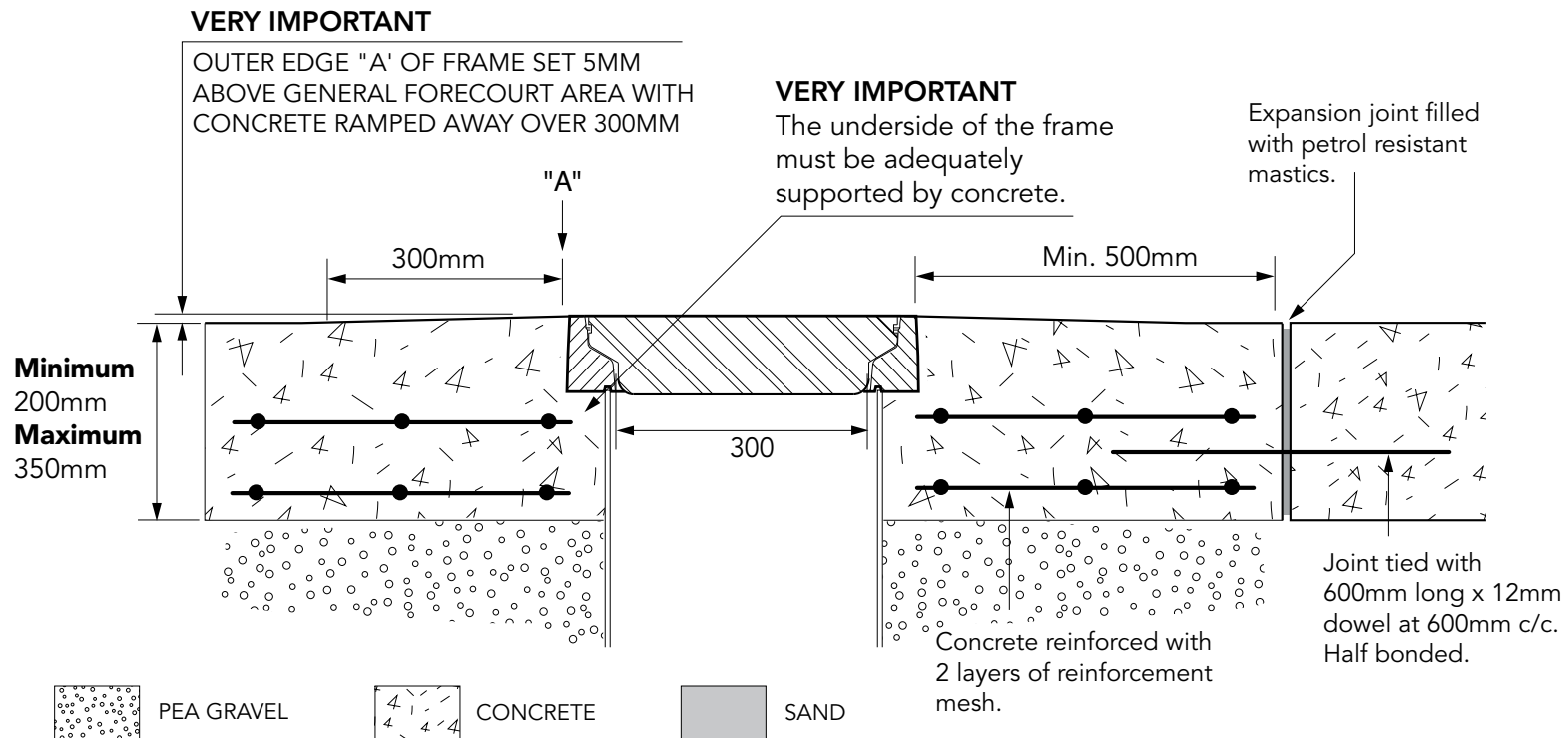

TARMACADAM

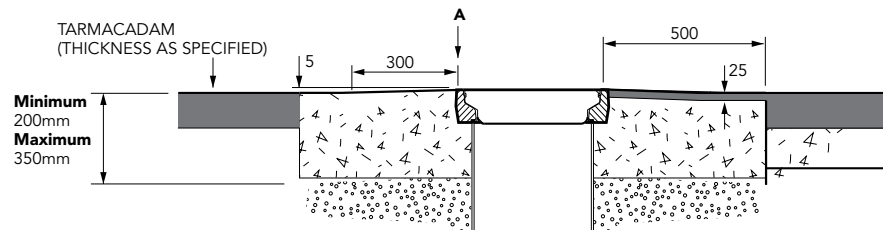

SETTS

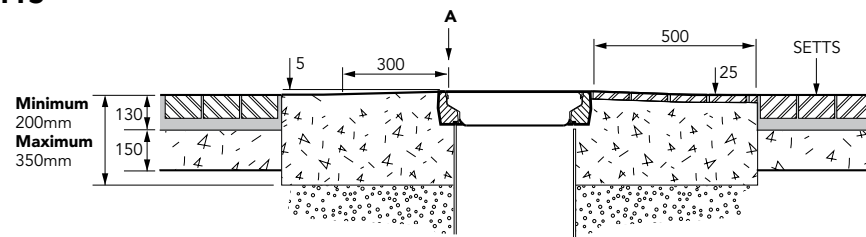

300mm diameter watertight flat sealed cover with composite frame. Temperature and chemical resistant. Designed for steam applications.

For reference purposes only. This drawing is not a specification. Order against product code only. To enable continuous improvement of our products, the designs and specifications are subject to change without notice.

