

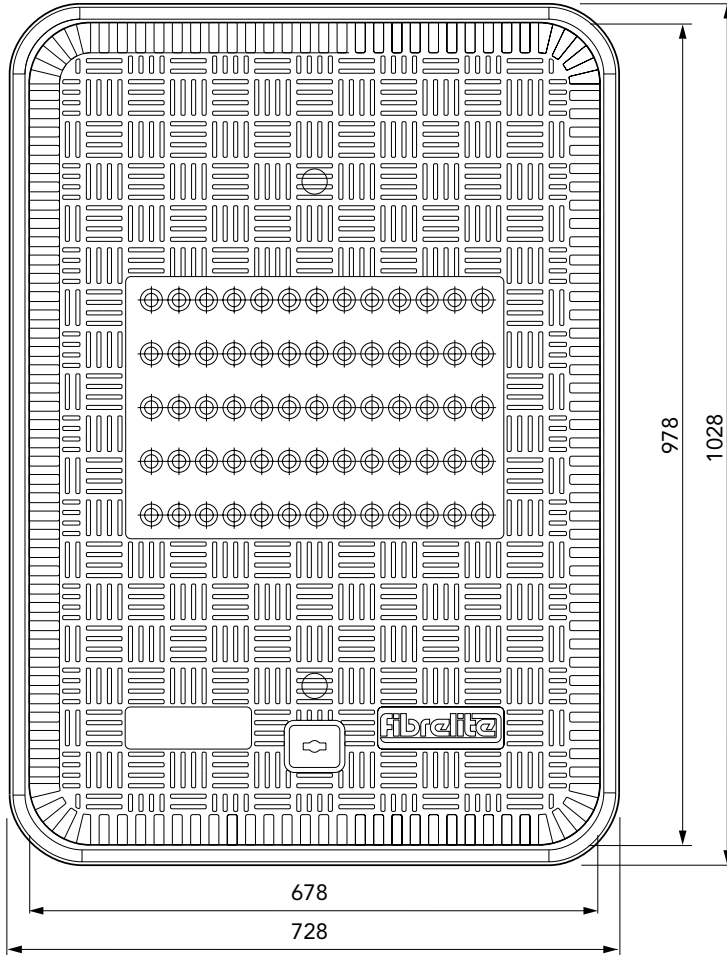

900mm x 600mm flat, vented composite cover with aluminium frame. Temperature and chemical resistant. Designed for steam applications.

For reference purposes only. This drawing is not a specification. Order against product code only. To enable continuous improvement of our products, the designs and specifications are subject to change without notice.

**FIBRELITE**   
PART OF OPW A DOVER COMPANY

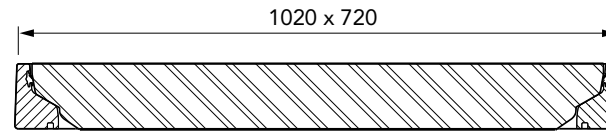
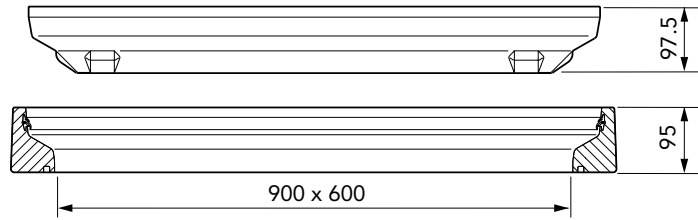

Load Rating	Cover Weight	Frame Weight
C250	27 kg	11 kg

900mm x 600mm flat, vented composite cover with aluminium frame. Temperature and chemical resistant. Designed for steam applications.

For reference purposes only. This drawing is not a specification. Order against product code only. To enable continuous improvement of our products, the designs and specifications are subject to change without notice.



# CONCRETE

## VERY IMPORTANT

OUTER EDGE "A" OF FRAME SET 5MM ABOVE GENERAL FORECOURT AREA WITH CONCRETE RAMPED AWAY OVER 300MM

## VERY IMPORTANT

The underside of the frame must be adequately supported by concrete.

Expansion joint filled with petrol resistant mastics.

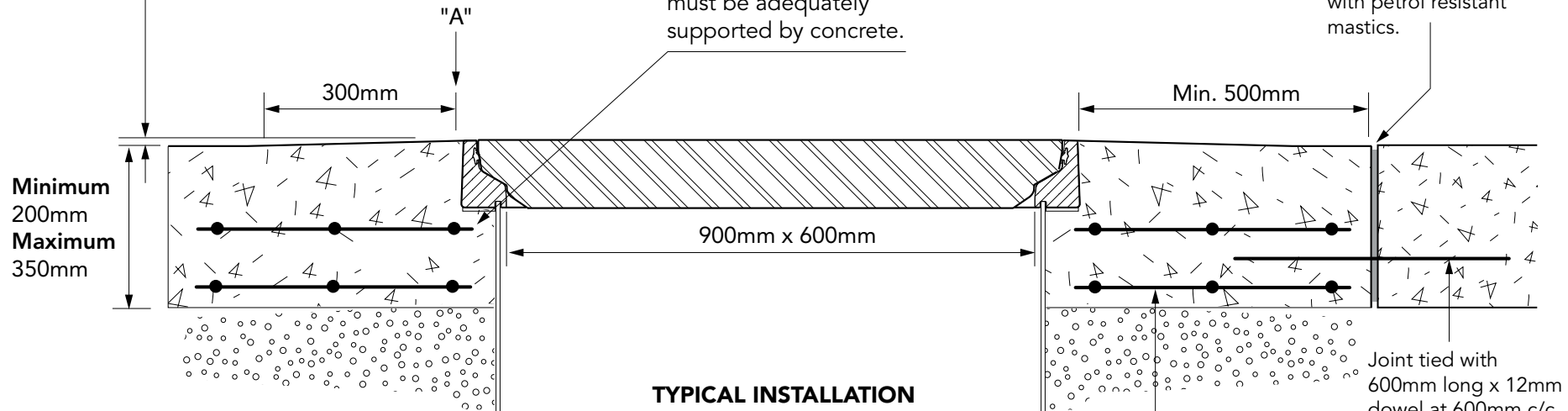

TYPICAL INSTALLATION



Concrete reinforced with 2 layers of reinforcement mesh.

# TARMACADAM

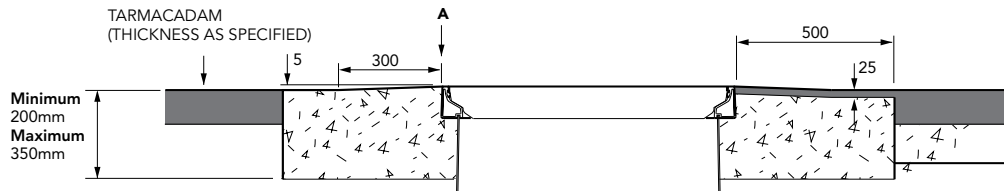

# SETTS

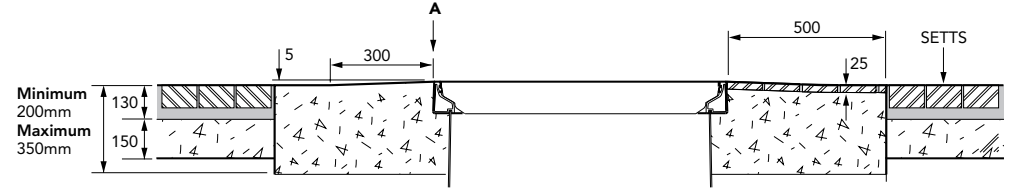

900mm x 600mm flat, vented composite cover with aluminium frame. Temperature and chemical resistant. Designed for steam applications.

For reference purposes only. This drawing is not a specification. Order against product code only. To enable continuous improvement of our products, the designs and specifications are subject to change without notice.

