

# GRP Chamber Systems

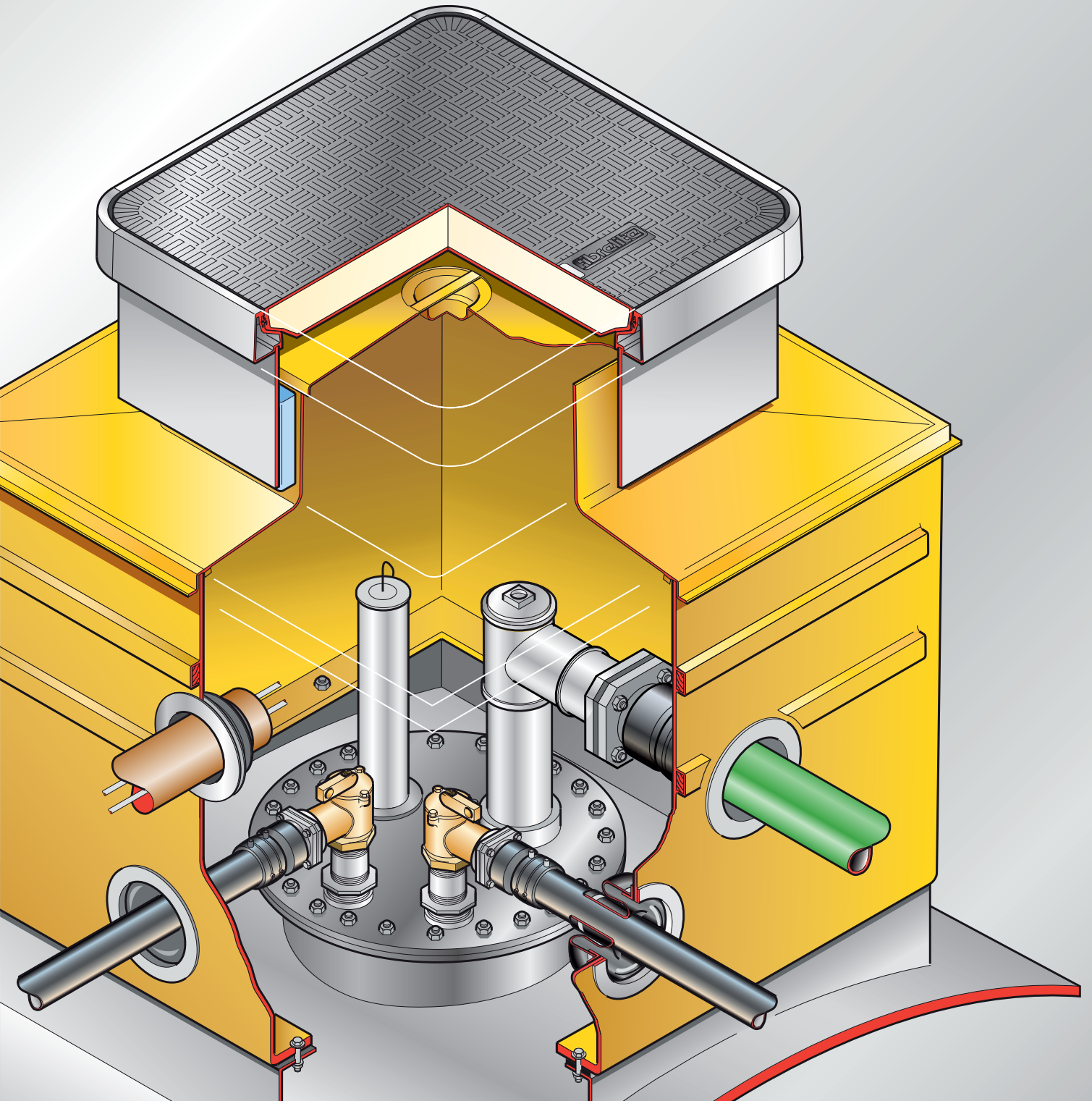

We've got you covered

**FIBRELITE** 

# Vacuum Testable, Anti-static, Non-corrosive,

## Forecourt Chamber Systems

Designed to be bolted onto square tank upstands, our GRP range offers a great alternative to metal sumps which frequently corrode and leak around pipework penetrations.

The systems are adjustable height which allows easy installation and eliminates the potential for load transfer from the cover to the tank. A non-structural internal lid is supplied as standard.

Square systems can only be buried up to 1.8 metres deep. All systems are vacuum testable.

### Bolted base systems with watertight flat sealed covers

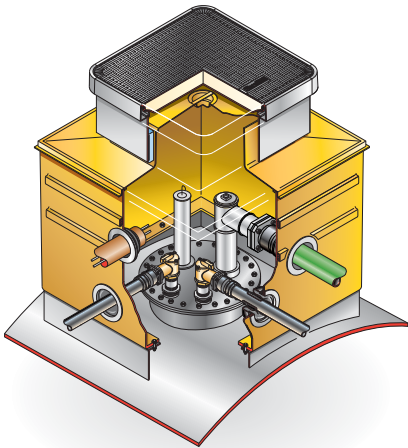

**S7-376**

Product Code	Description
S6-376	1.2m <sup>2</sup> chamber with a corbel, skirt, non-structural internal lid and 760mm <sup>2</sup> flat sealed cover and frame. Chamber has a 1m <sup>2</sup> tank upstand connection.
S6-390	1.2m <sup>2</sup> chamber with a corbel, skirt, non-structural internal lid and 900mm dia. flat sealed cover and frame. Chamber has a 1m <sup>2</sup> tank upstand connection.
S7-376	1.2m <sup>2</sup> chamber with a corbel, skirt, non-structural internal lid and 760mm <sup>2</sup> flat sealed cover and frame
S7-390	1.2m <sup>2</sup> chamber with a corbel, skirt, non-structural internal lid and 900mm dia. flat sealed cover and frame

Solid base systems are available if required.

Order structural platforms separately for manual dip and fill risers if required. Refer to GRP Structural Platform table for information.

The standard colour of the cover is black. Covers can also be supplied with dip ports if required. Refer to Manual Dip Port Covers table for information.

The covers are available in both C250 (25 tonnes) and D400 (40 tonnes) load ratings.

## Green Area Chamber Systems

Our lockable GRP systems offer a cost effective, non-corrosive alternative to metal chambers.

All systems are vacuum testable.

### Bolted base systems with a lockable lid

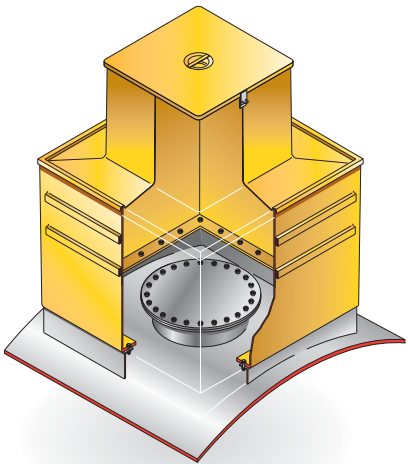

**S7-2/G**

Product Code	Description
S6/GREEN-AREA	1.2m <sup>2</sup> chamber with a corbel and 760mm <sup>2</sup> lockable lid. Chamber has a 1m <sup>2</sup> tank upstand connection.
S7/GREEN-AREA	1.2m <sup>2</sup> chamber with a corbel and 760mm <sup>2</sup> lockable lid. Chamber has a 1.2m <sup>2</sup> tank upstand connection.

# Watertight Solutions

## Manual Dip Port Covers

Designed for quick and easy access to a manual dip stick located inside the tank sump. The dip port covers are sealed, and can be located in a central or offset position in the cover as required.

The dip port covers can also be colour coded to the fuel grade and chained to main cover for added security. The covers are available in both C250 (25 tonnes) and D400 (40 tonnes) load ratings.

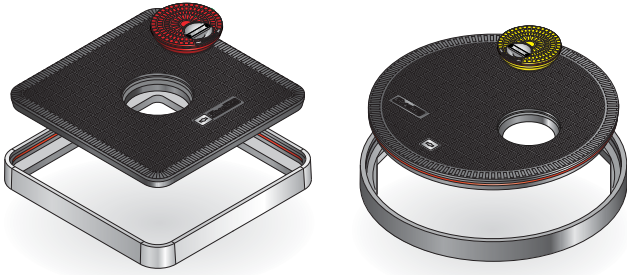

### Product Code Description

FL76/CD	760x760mm flat sealed cover with centre dip port & aluminium frame
FL76/OD	760x760mm flat sealed cover with offset dip port & aluminium frame
FL90/CD	900mm dia. flat sealed cover with centre dip port & composite frame
FL90/OD	900mm dia. flat sealed cover with offset dip port & composite frame

## Accessories

### GRP Chamber Extensions

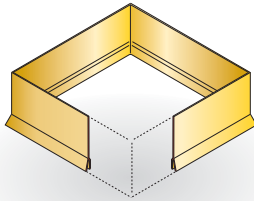

S7/EX300

Install only one extension per chamber system.

### Product Code Description

S7/EX300	300mm deep extension to fit S6, S7 and S7SB sumps
----------	---

### GRP Structural Platforms

Non-structural internal lids are supplied as standard with all chamber systems.

Structural platforms are designed with a safe working load of 200kg and are coated with a tough anti-slip finish. We recommend that they are installed for manual dip applications.

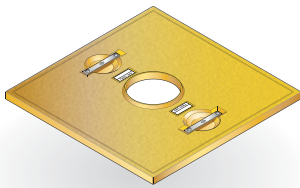

S/S-LID/SQUARE/20

### Product Code Description

S/S-LID/SQUARE/20	Square platform with one central hole (200mm dia) with upward lip. Designed for central manual dip and fill riser.
S/S-LID/SQUARE/SOLID	Solid square platform, 6 hole positions marked to be cut to suit offset manual dip.

### High Groundwater Sealkits

Designed to seal between the corbel and skirt of our height adjustable sump systems, the flexible sealant allows for ground movement. This eliminates potential load transfer from the cover to the tank.

A water collection bottle and drain is designed to collect any condensation build up inside a sealed system, which collects in the sealed recess and drains into the bottle. The sealant is resistant to hydrocarbons.

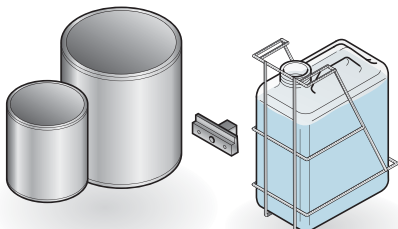

### Product Code Description

S/CS/SEALKIT	Half tin sealant (Tins A & B), bottle, cage, drain & fixing kit
S/CS/SEALANT	1 tin sealant (A), 1 tin catalyst (B)
S/CS/BOTTLE	Bottle, cage, drain and fixings
S/BOTTLE	Bottle only
S/CAGE	Hanging cage for bottle
S/DRAIN	Drain with fixing kit





Fibresec  
GROUP  
COMPANY



TÜV



FM 37923

**Fibrelite's commitment towards maintaining the highest possible standards**

Fibrelite products are manufactured in the US and UK only, to ensure the strictest control on raw material quality and manufacturing standards. All products are manufactured in accordance with ISO 9001.2000. ISO accreditation applies to the UK manufacturing plant.

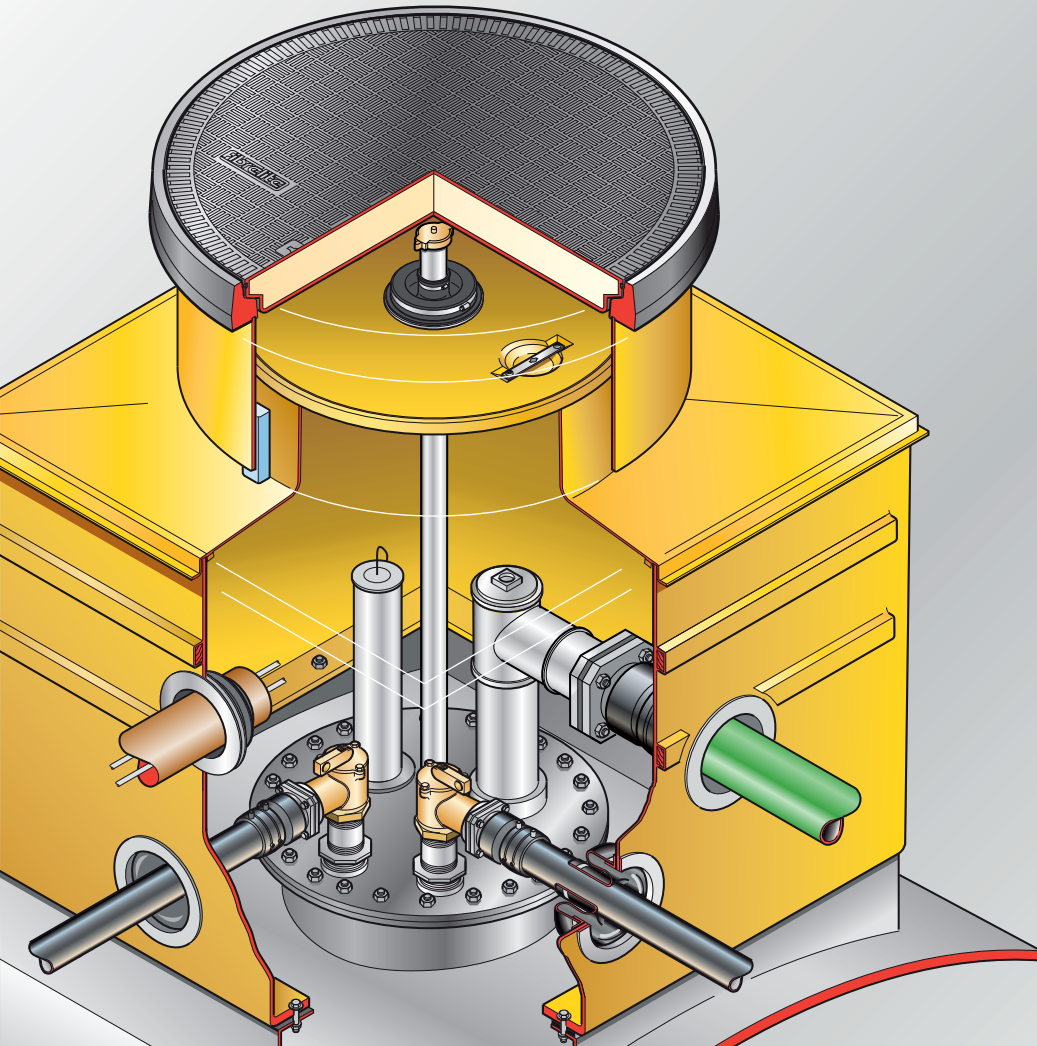

**FIBRELITE**   
PART OF OPW A HONEYWELL COMPANY

**UK Office:**

Snaygill Industrial Estate, Keighley Road, Skipton, North Yorkshire, BD23 2QR, UK

Tel: +44 (0) 1756 794 963

E-mail: [enquiries@fibrelite.com](mailto:enquiries@fibrelite.com) , Website: [www.fibrelite.com](http://www.fibrelite.com)

**US Office:**

3250 US Highway 70 Business West, Smithfield, NC 27577, USA

Tel: + 1 919 209 2404 Fax: +1 (800) 421 3297

E-mail: [enquiries@fibrelite.com](mailto:enquiries@fibrelite.com)