

- Substations
- Power Plants
- Co-Gen Facilities
- Wind Farms
- Refineries
- Universities
- Correctional Institutions
- Industrial Plants
- Telecommunication Sites
- Waste Water Treatment Plants



**Fibrelite Trench Lids**

Manufactured from high performance polymers and engineered to outperform similar products made from concrete and fiberglass reinforced concrete materials, these lids are lightweight, yet tough enough to withstand traffic and harsh field conditions.

# Lightweight Composite Lids for Tier 15 Crossing Trench

Engineered monolithic construction

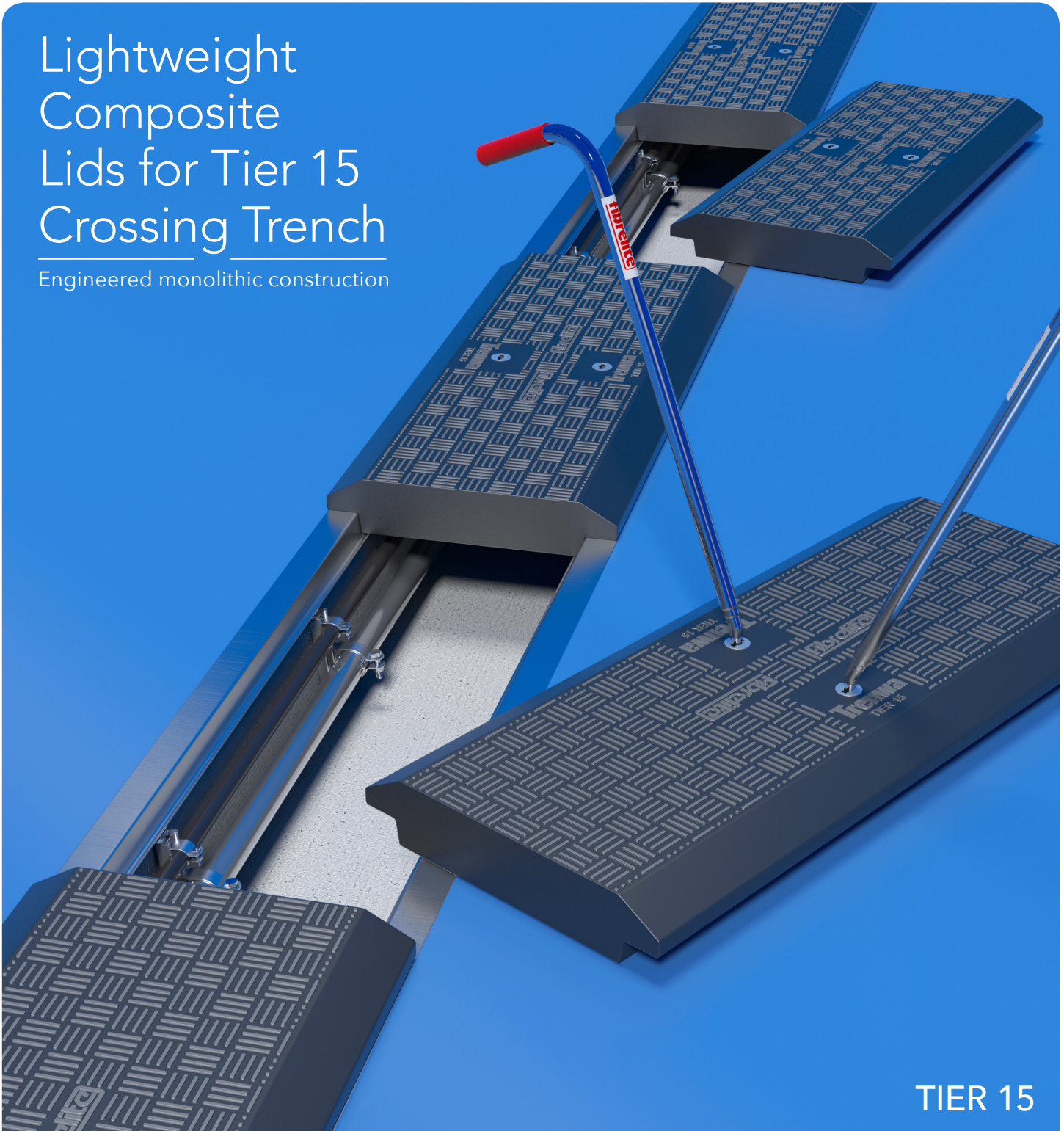

**TIER 15**

Developed over 50 years ago by Trenwa - precast concrete trench is our specialty. With four modern, strategically located plants, we are the country's leading producer of durable, precast trench systems in the broadest range of types and sizes.

**Tel:** +1 859 781 0831

1419 Alexandria Pike

**Fax:** +1 859 781 1085

Fort Thomas

**Email:** info@trenwa.com

KY 41075

USA



## Why Fibrelite?

Fibrelite has been at the forefront of composite quality and innovation since 1980 when we designed the world's first FRP composite manhole cover for the retail petroleum industry. And our high-performance, lightweight and safe-to-lift composite covers are now selected by specifiers, architects and engineers worldwide.



Easy lift FRP Fibrelite covers



Fibrelite covers are corrosion resistant

## Why Choose a Fibrelite Trench Cover?

Although FRP composite covers are now increasingly preferred to the traditional metal or concrete options - not every composite cover is going to perform to the highest standards year after year.

With a Fibrelite trench cover you can be sure that you have a high performance product created via resin transfer molding (RTM) to create a durable, monolithic cover that you can fit-and-forget. What's more, each one will have been individually engineered under the watchful eye of our technical teams in our own manufacturing facilities in the USA, UK and Malaysia.



Developed over 50 years ago by Trenwa - precast concrete trench is our specialty. With four modern, strategically located plants, we are the country's leading producer of durable, precast trench systems in the broadest range of types and sizes.

**Tel:** +1 859 781 0831

**Fax:** +1 859 781 1085

**Email:** info@trenwa.com

1419 Alexandria Pike

Fort Thomas

KY 41075

USA



## No Risk of Theft

There is no risk of theft with a Fibrelite composite cover as composites have no resale value in the scrap market - so you won't be left with a dangerous, uncovered hole in the ground.



## Durability

Designed as a 'fit-and-forget' product, our FRP composite covers are maintenance-free, durable and very strong as a matter of course.



## Skid Resistance

Independent wet and dry tests carried out by Devon CC Materials Laboratory (UK) showed that Fibrelite trench covers – even when wet - had anti-slip properties equivalent to a modern high grade road surface which far exceeds health and safety advisory limits.



## Corrosion Resistance

A prime reason for selecting a composite cover is because of its inherent resistance to corrosion making it an obvious choice where water, wastewater or corrosive liquids are involved. They are also ideal where underground infrastructure requires protection from external corrosive compounds such as salt.



## Ergonomically Lifting Handle

As well as being lightweight – typically a third of the weight of an equivalent-size cover produced in metal or concrete - the ergonomically designed lifting aid has the added benefit of eliminating the risk of back injury and crushed fingers.



Developed over 50 years ago by Trenwa - precast concrete trench is our specialty. With four modern, strategically located plants, we are the country's leading producer of durable, precast trench systems in the broadest range of types and sizes.

**Tel:** +1 859 781 0831

1419 Alexandria Pike

**Fax:** +1 859 781 1085

Fort Thomas

**Email:** info@trenwa.com

KY 41075

# Engineering Specifications

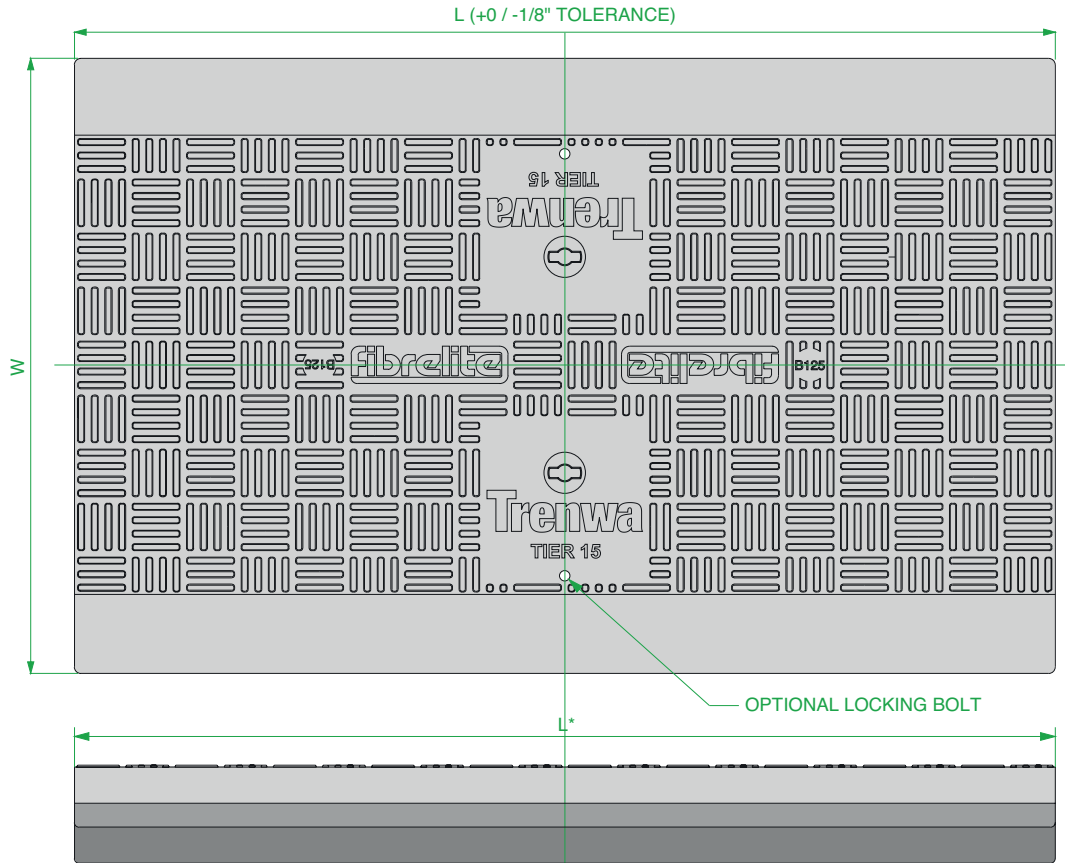

- Lightweight composite construction
- Chip and crack resistant
- Freeze / thaw cycle impervious
- Non-conductive
- Chemically inert
- Exceeds service requirements
- 15 year warranty

- Anti-slip / anti-static surface
- Non-corrosive
- Custom colors available
- No scrap value
- Weather resistant
- Maintenance free
- UV stable

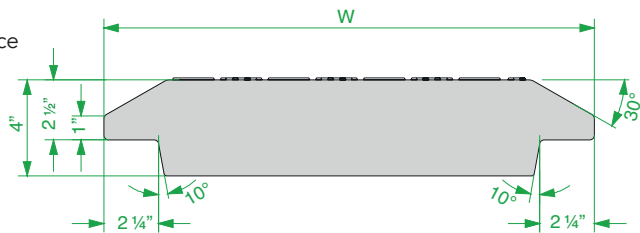

COVER CODE	W = WIDTH (INCHES)	L* = LENGTH (INCHES)	WEIGHT (LBS)
LMF16-60	16	60	41
LMF26-60	26	60	62
LMF30-60	30	60	70
LMF36-60	36	60	82
LMF46-30	46	30	82
LMF46-40	46	40	105
LMF54-30	54	30	95
LMF54-40	54	40	125

\* +0 / -1/8" TOLERANCE

SPECIAL LENGTHS LESS THAN 1/2 A STANDARD LID WILL NOT HAVE LIFTING INSERTS

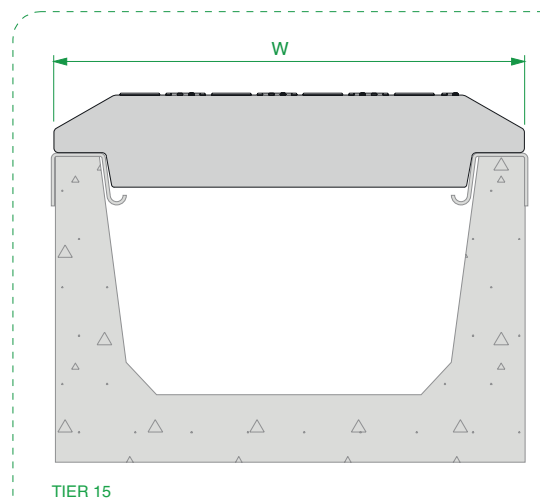

Developed over 50 years ago by Trenwa - precast concrete trench is our specialty. With four modern, strategically located plants, we are the country's leading producer of durable, precast trench systems in the broadest range of types and sizes.

Tel: +1 859 781 0831

1419 Alexandria Pike

Fax: +1 859 781 1085

Fort Thomas

Email: info@trenwa.com

KY 41075

Trenwa - Tough Enough to Trust

www.trenwa.com

Page: 4 of 5

USA

## Our Load Test Reports

All our trench covers are independently tested in accordance with strict criteria and not only meet but often surpass the relevant class conditions for deflection under load as demonstrated in the reports.

Trench covers supplied for use in the US have also been independently tested to ensure that they meet AASHTO (American Association of State Highway & Transportation Officials) standards.



## Accreditations

Fibrelite has held accreditation to the ISO quality standard (ISO 9001:2008) and British Standards Kitemark since 1998 and this commitment to product excellence enables us to provide the most comprehensive range of high strength modular and custom-made trench covers with the very best strength to weight ratio available in the market today.

Our covers:

- exceed H20 and H25 load rating standards.



## Locks Available

Locks and restraining bolts available for added security.

