

Fibrelite Lightweight Composite Lids For HS20 Road Crossing Trenches

Manufactured from high performance polymers and engineered to outperform similar products made from concrete and fiberglass reinforced concrete materials, these lids are lightweight, yet tough enough to withstand traffic and harsh field conditions.

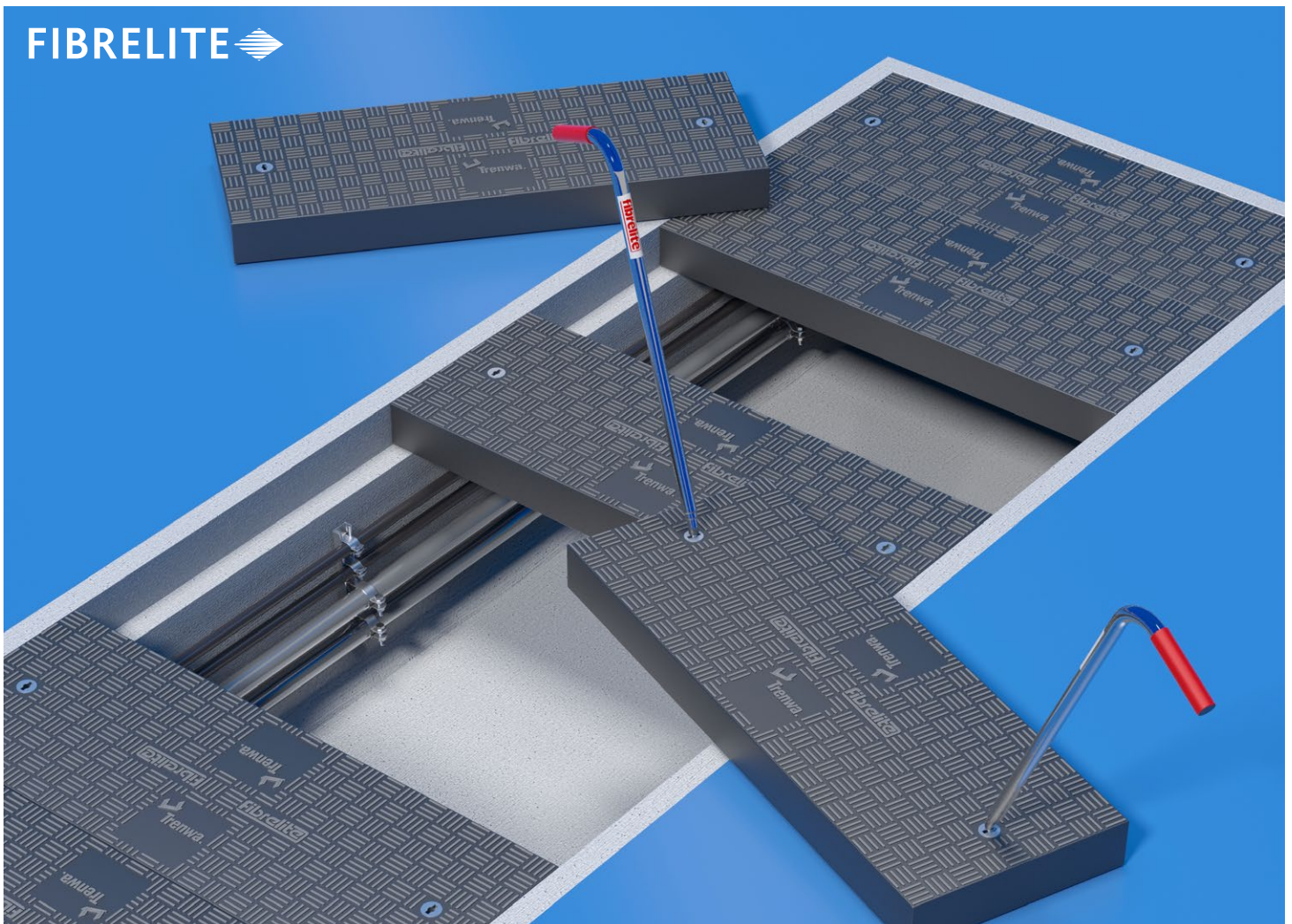

Substations • Power Plants • Co-Gen Facilities • Wind Farms • Refineries • Universities
Data Centers • Industrial Plants • Telecommunication Sites • Waste Water Treatment Plants

Fibrelite Lightweight Composite Lids for HS20 Road Crossing Trenches

Engineering Specifications & Benefits

- Lightweight FRP composite construction
- Chip and crack resistant
- Safe, fast manual removal and replacement with the Fibrelite FL7 lifting handles
- Freeze / thaw cycle impervious
- Non-conductive
- Chemically inert
- Exceeds service requirements
- Anti-slip / anti-static surface
- Non-corrosive
- Custom colors available
- No scrap value
- Weather resistant
- Maintenance-free
- UV stable

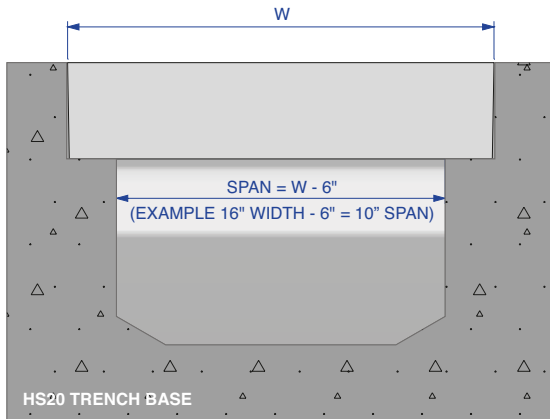
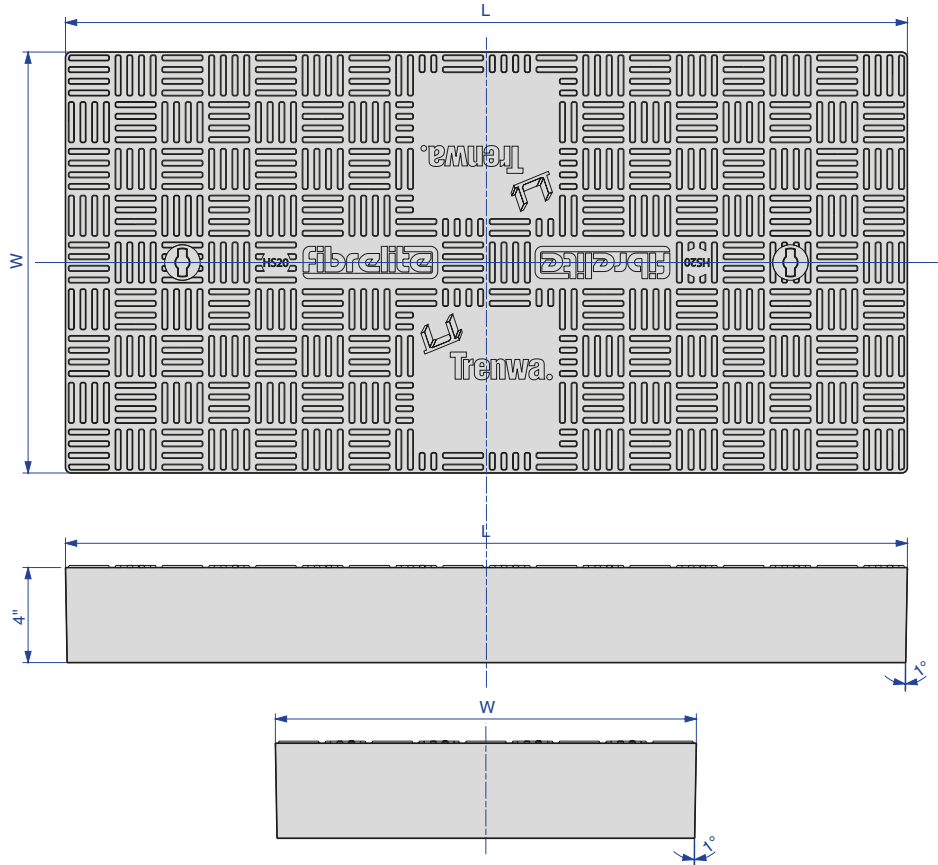

COVER CODE	W = WIDTH (INCHES)	L* = LENGTH (INCHES)	WEIGHT (LBS)
LHF16-60	16	60	55
LHF26-60	26	60	80
LHF30-60	30	60	95
LHF36-30	36	30	60
LHF36-60	36	60	118
LHF46-20	46	20	68
LHF46-30	46	30	98
LHF54-20	54	20	90
LHF54-30	54	30	138

*+0 /-1/8" Tolerance. All LHF panel sizes are also available in HS-25 (50K) and HS-40 (64K) load ratings. Contact Trenwa for more information.

Trenwa – Tough Enough to Trust

Family owned and operated since 1961 – precast concrete trench is our specialty. With four modern, strategically located plants, we are the country's leading producer of durable, precast trench systems in the broadest range of types and sizes.

Tel: (859) 781 0831
Fax: (859) 781 1085
Email: info@trenwa.com

Address: 1419 Alexandria Pike,
Fort Thomas, KY 41075, USA

FIBRELITE 
PART OF OPW a DOVER company

Fibrelite Lightweight HS20 Lids – Accessories



Ergonomic Lifting Handle

FL7 cover lifting handle.

Size: 7" (W) x 31" (H)



Lifting Handle Cabinet

The FL7A-ENCL cabinet is designed to fit two lifting handles securely. A lock and key are provided.

Size: 14" (W) x 36" (H) x 4" (D)

Trenwa – Tough Enough to Trust

Family owned and operated since 1961 – precast concrete trench is our specialty. With four modern, strategically located plants, we are the country's leading producer of durable, precast trench systems in the broadest range of types and sizes.

Tel: (859) 781 0831
Fax: (859) 781 1085
Email: info@trenwa.com
Address: 1419 Alexandria Pike,
Fort Thomas, KY 41075, USA

FIBRELITE 
PART OF OPW a **DOVER** company