

Fixed height 450mm deep, 300mm dia. solid base sump with a 300mm dia. flat sealed cover and frame.

For reference purposes only. This drawing is not a specification. Order against product code only. To enable continuous improvement of our products, the designs and specifications are subject to change without notice.

**FIBRELITE**   
PART OF OPW A DOVER COMPANY

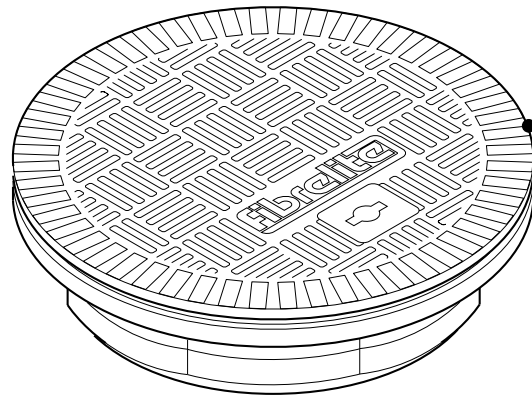

FL120

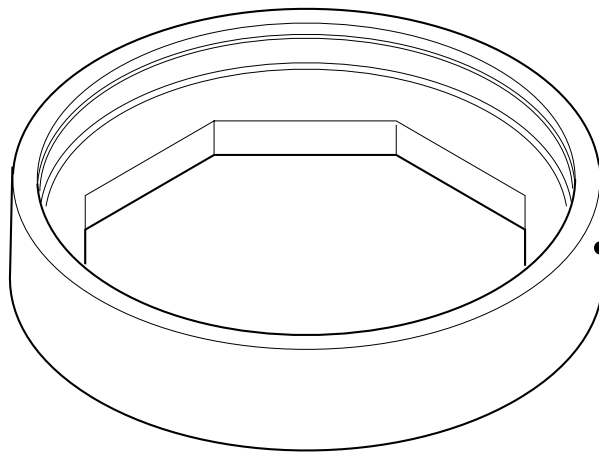

FL120 FRAME

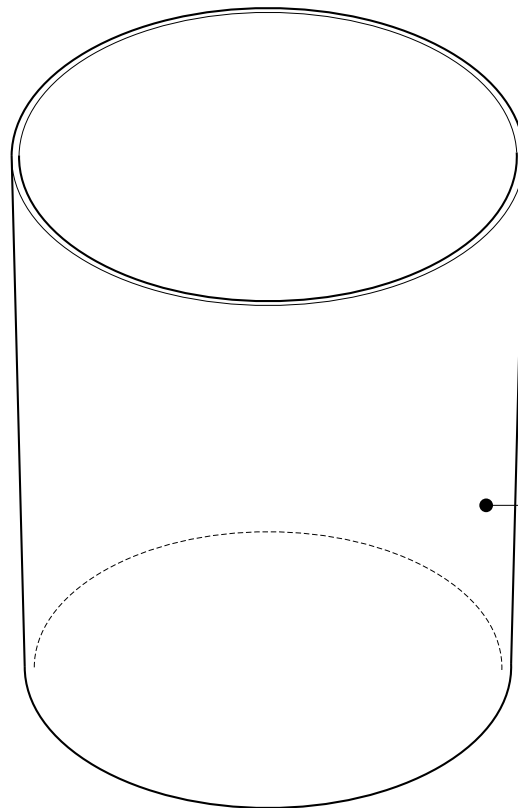

S0SH SOLID BASE SUMP

Fixed height 450mm deep, 300mm dia. solid base sump with a 300mm dia. flat sealed cover and frame.

For reference purposes only. This drawing is not a specification. Order against product code only. To enable continuous improvement of our products, the designs and specifications are subject to change without notice.

**FIBRELITE**   
PART OF OPW A DOVER COMPANY

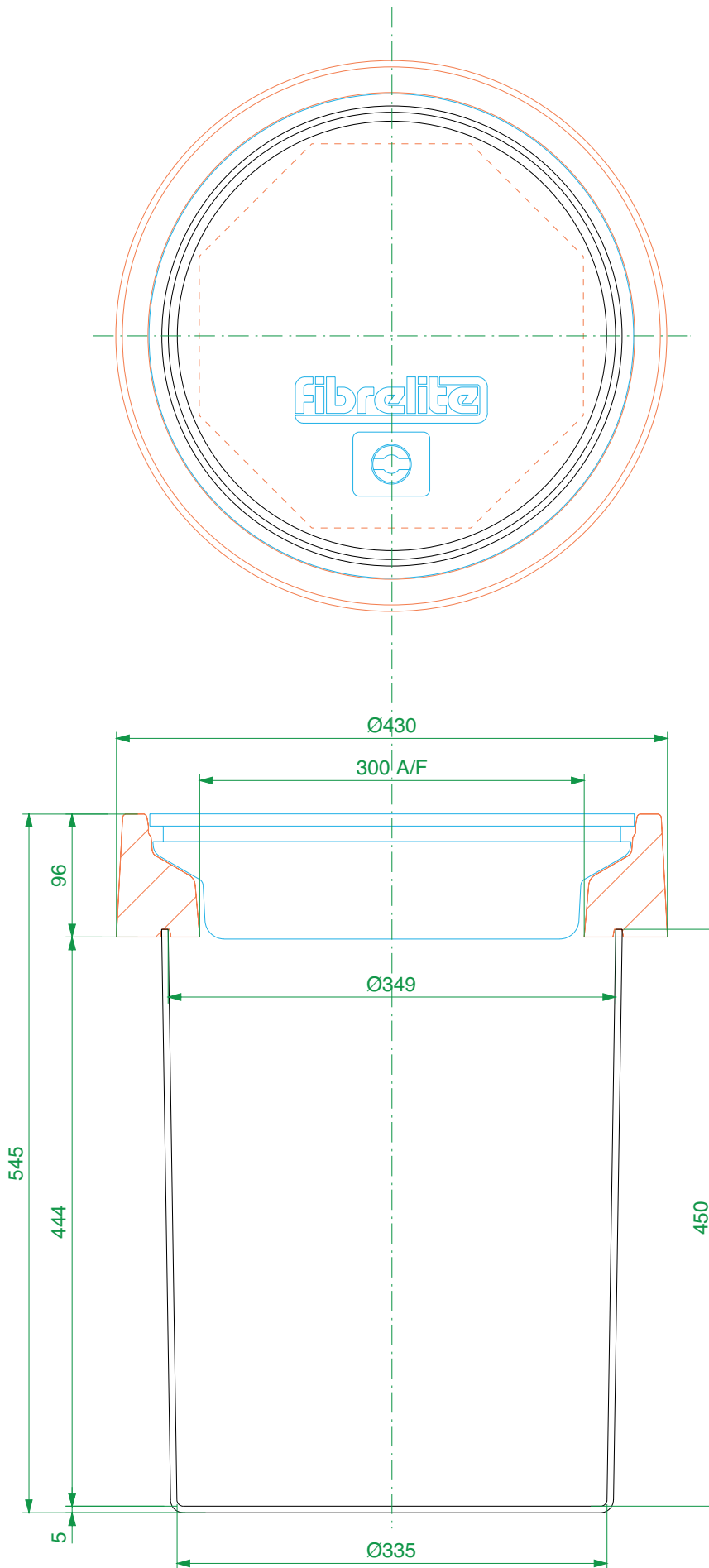

Fixed height 450mm deep, 300mm dia. solid base sump with a 300mm dia. flat sealed cover and frame.

For reference purposes only. This drawing is not a specification. Order against product code only. To enable continuous improvement of our products, the designs and specifications are subject to change without notice.

**FIBRELITE**   
PART OF OPW A DOVER COMPANY

**! VERY IMPORTANT !**  
 SET OUTER EDGE 'A' OF  
 FRAME 25MM ABOVE GENERAL  
 FORECOURT AREA RAMPED  
 AWAY OVER 450MM.

TYPICAL INSTALLATION

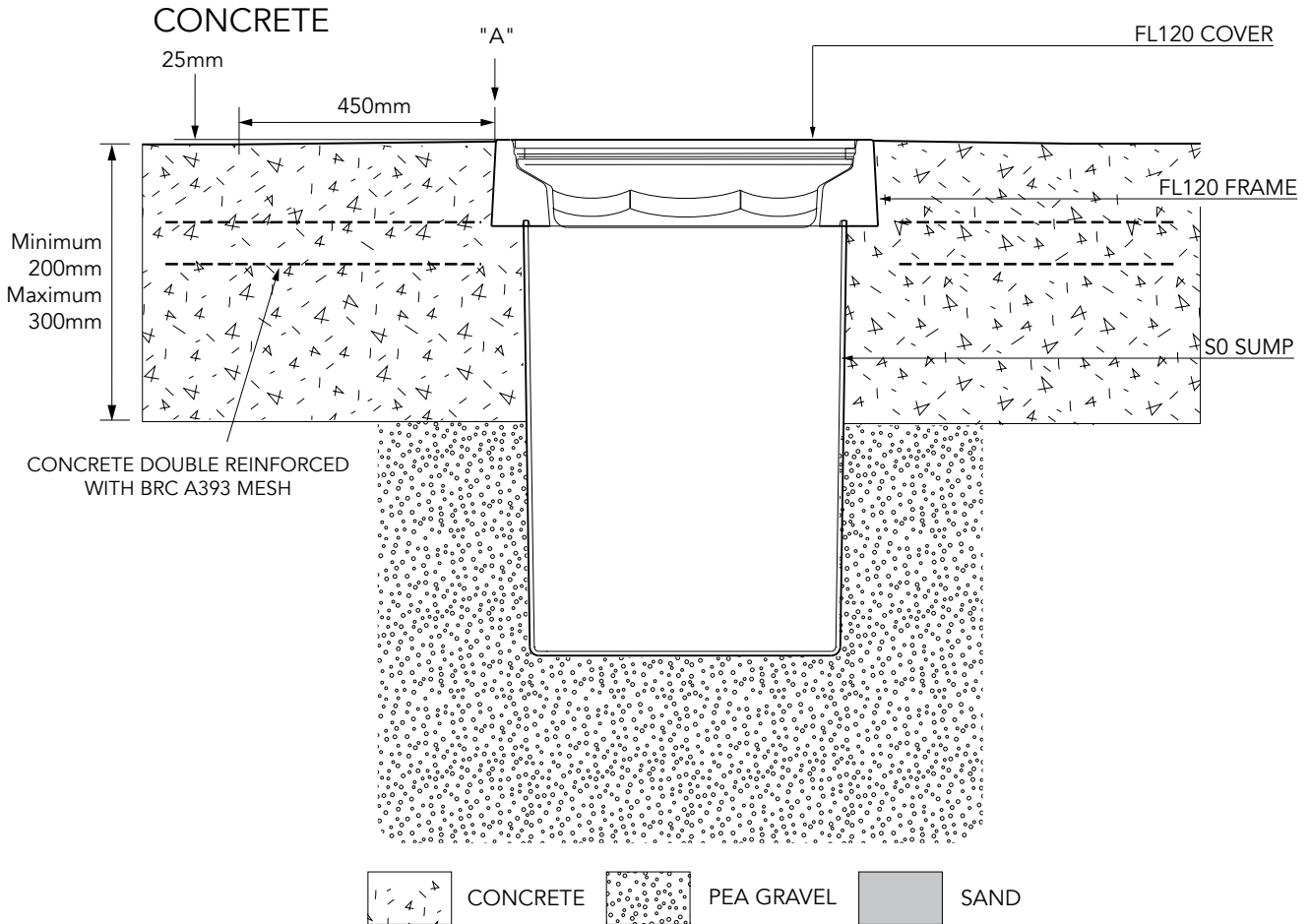

ALTERNATIVE INSTALLATION ADVICE

TARMACADAM

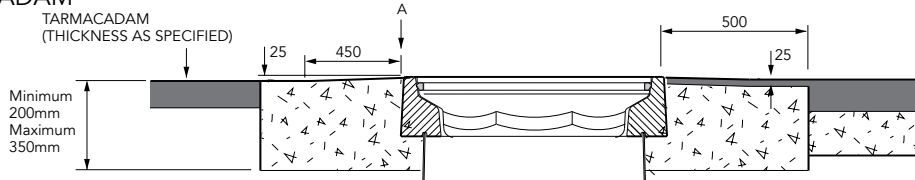

Fixed height 450mm deep, 300mm dia. solid base sump with a 300mm dia. flat sealed cover and frame.

For reference purposes only. This drawing is not a specification. Order against product code only. To enable continuous improvement of our products, the designs and specifications are subject to change without notice.

**FIBRELITE**   
 PART OF OPW A DOVER COMPANY