

1.4m diameter bolted base chamber, sealed corbel with a height adjustable skirt, non-structural internal lid, round 900mm flat sealed cover with a central port cover and frame.

For reference purposes only. This drawing is not a specification. Order against product code only. To enable continuous improvement of our products, the designs and specifications are subject to change without notice.

**FIBRELITE**   
PART OF OPW A DOVER COMPANY

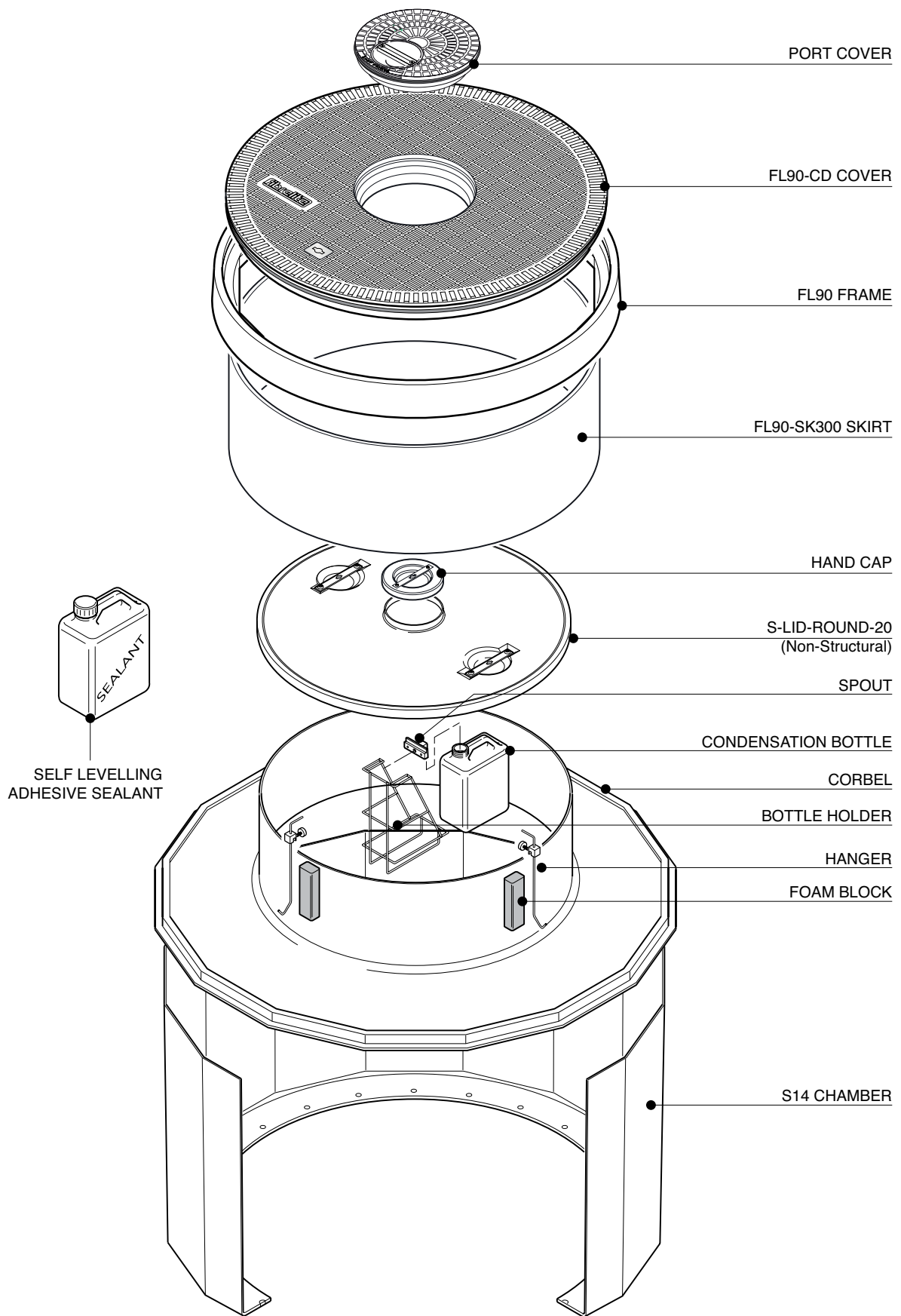

1.4m diameter bolted base chamber, sealed corbel with a height adjustable skirt, non-structural internal lid, round 900mm flat sealed cover with a central port cover and frame.

For reference purposes only. This drawing is not a specification. Order against product code only. To enable continuous improvement of our products, the designs and specifications are subject to change without notice.

**FIBRELITE**   
PART OF OPW A DOVER COMPANY

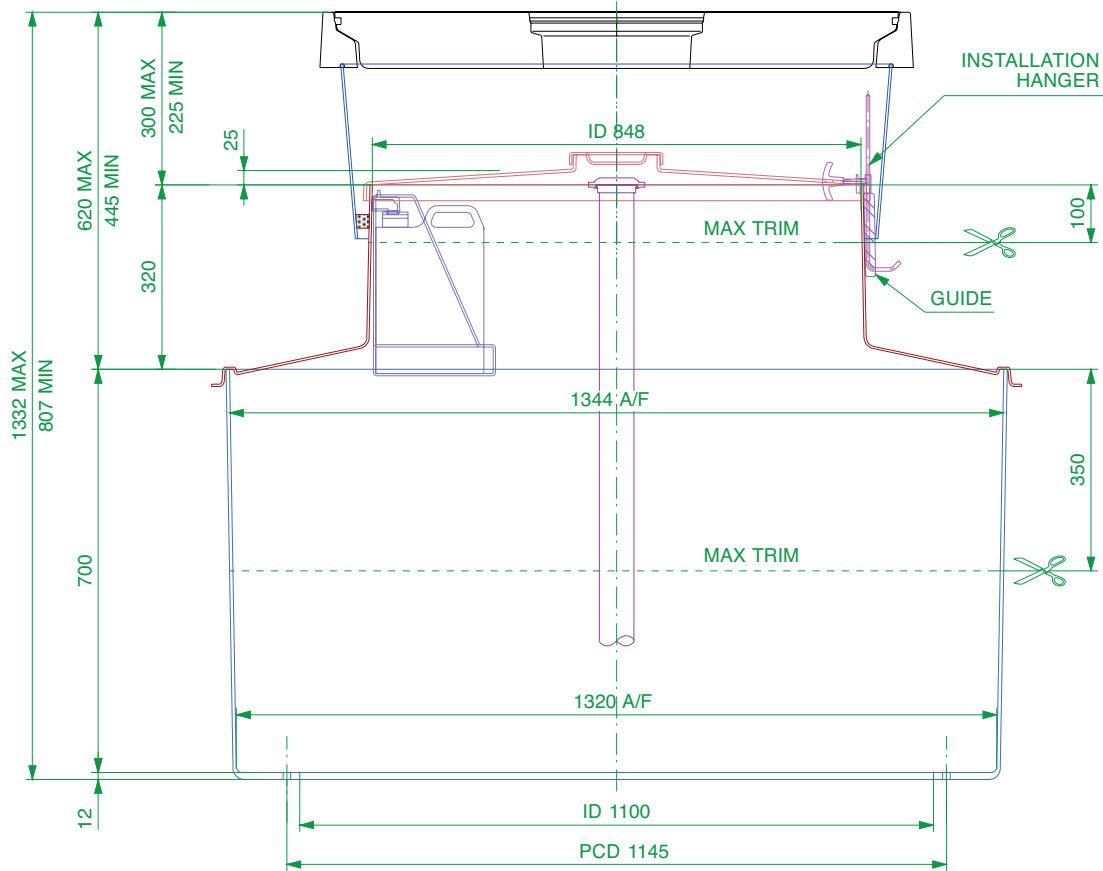
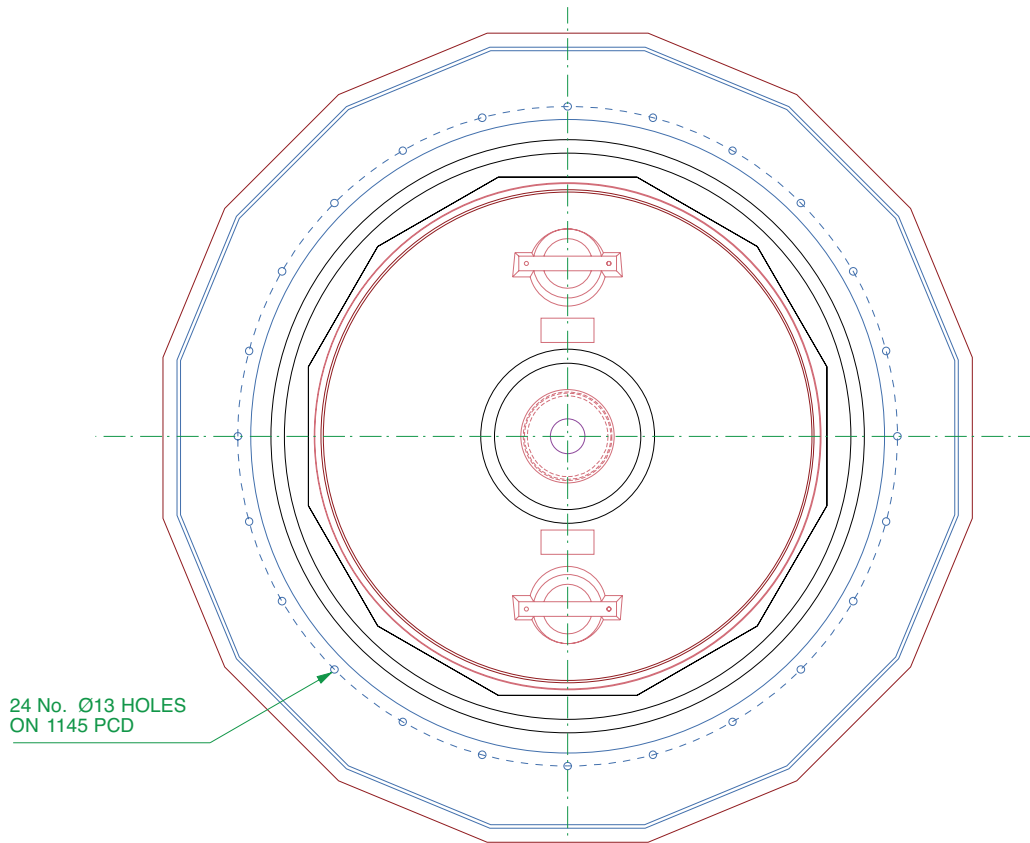

1.4m diameter bolted base chamber, sealed corbel with a height adjustable skirt, non-structural internal lid, round 900mm flat sealed cover with a central port cover and frame.

For reference purposes only. This drawing is not a specification. Order against product code only. To enable continuous improvement of our products, the designs and specifications are subject to change without notice.

**FIBRELITE**   
PART OF OPW A DOVER COMPANY

**VERY IMPORTANT**  
 OUTER EDGE "A" OF FRAME SET 5 - 10MM  
 ABOVE GENERAL FORECOURT AREA WITH  
 CONCRETE RAMPED AWAY OVER 300MM.

TYPICAL INSTALLATION

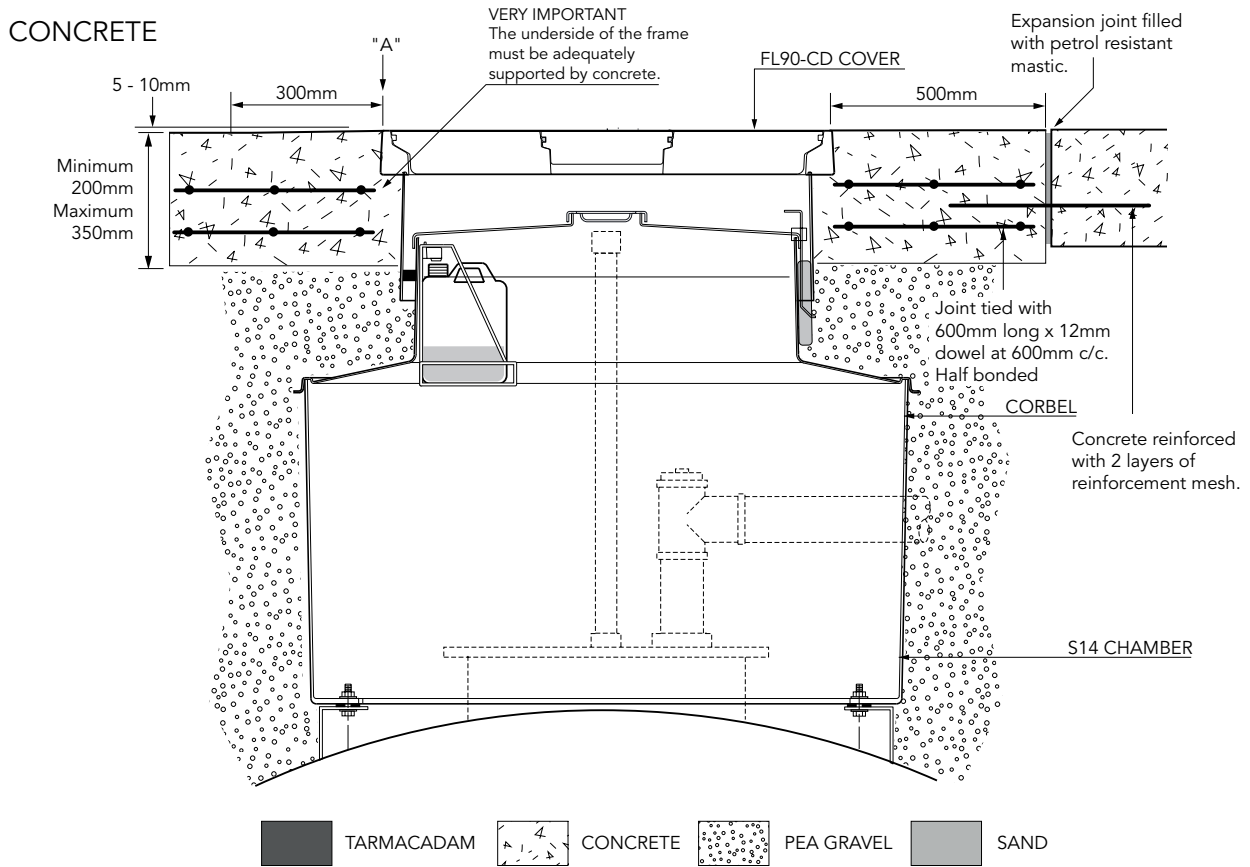

ALTERNATIVE INSTALLATION ADVICE

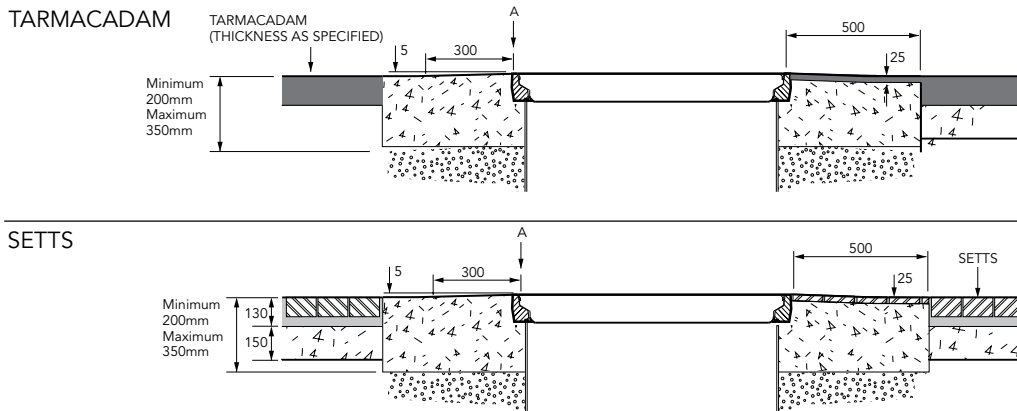

1.4m diameter bolted base chamber, sealed corbel with a height adjustable skirt, non-structural internal lid, round 900mm flat sealed cover with a central port cover and frame.

For reference purposes only. This drawing is not a specification. Order against product code only. To enable continuous improvement of our products, the designs and specifications are subject to change without notice.

