

1.4m dia. chamber, sealed corbel with a height adjustable skirt, watertight lid, 900mm flat sealed cover and frame. Exxon Mobil European Tank Chamber.

For reference purposes only. This drawing is not a specification. Order against product code only. To enable continuous improvement of our products, the designs and specifications are subject to change without notice.

**FIBRELITE**   
PART OF OPW A DOVER COMPANY

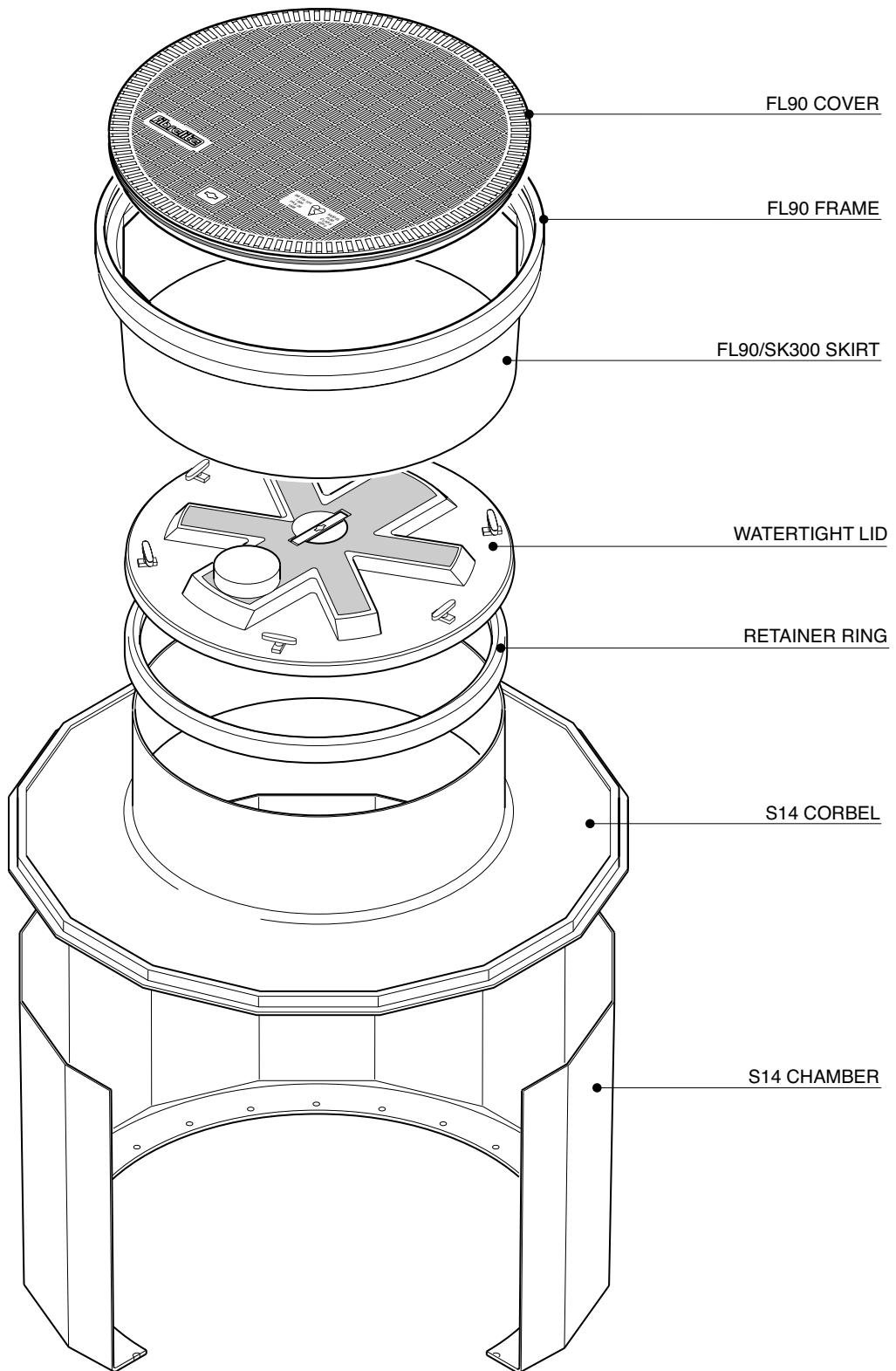

1.4m dia. chamber, sealed corbel with a height adjustable skirt, watertight lid, 900mm flat sealed cover and frame. Exxon Mobil European Tank Chamber.

For reference purposes only. This drawing is not a specification. Order against product code only. To enable continuous improvement of our products, the designs and specifications are subject to change without notice.

**FIBRELITE**   
PART OF OPW A DOW COMPANY

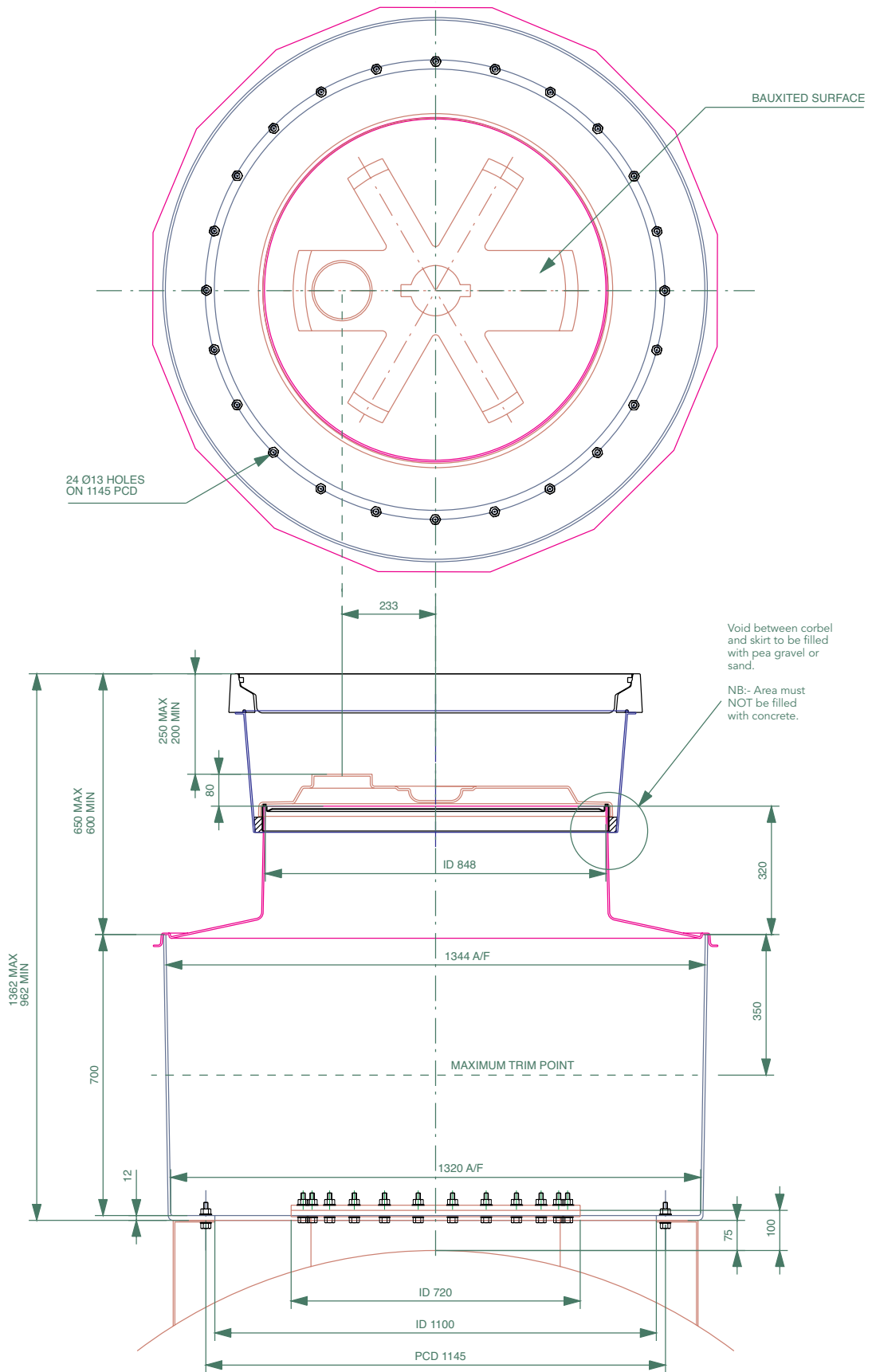

1.4m dia. chamber, sealed corbel with a height adjustable skirt, watertight lid, 900mm flat sealed cover and frame. Exxon Mobil European Tank Chamber.

For reference purposes only. This drawing is not a specification. Order against product code only. To enable continuous improvement of our products, the designs and specifications are subject to change without notice.

**FIBRELITE**   
PART OF OPW A DOWDER COMPANY

**VERY IMPORTANT**  
 OUTER EDGE "A" OF FRAME SET 5 - 10MM  
 ABOVE GENERAL FORECOURT AREA WITH  
 CONCRETE RAMPED AWAY OVER 300MM.

**TYPICAL INSTALLATION**

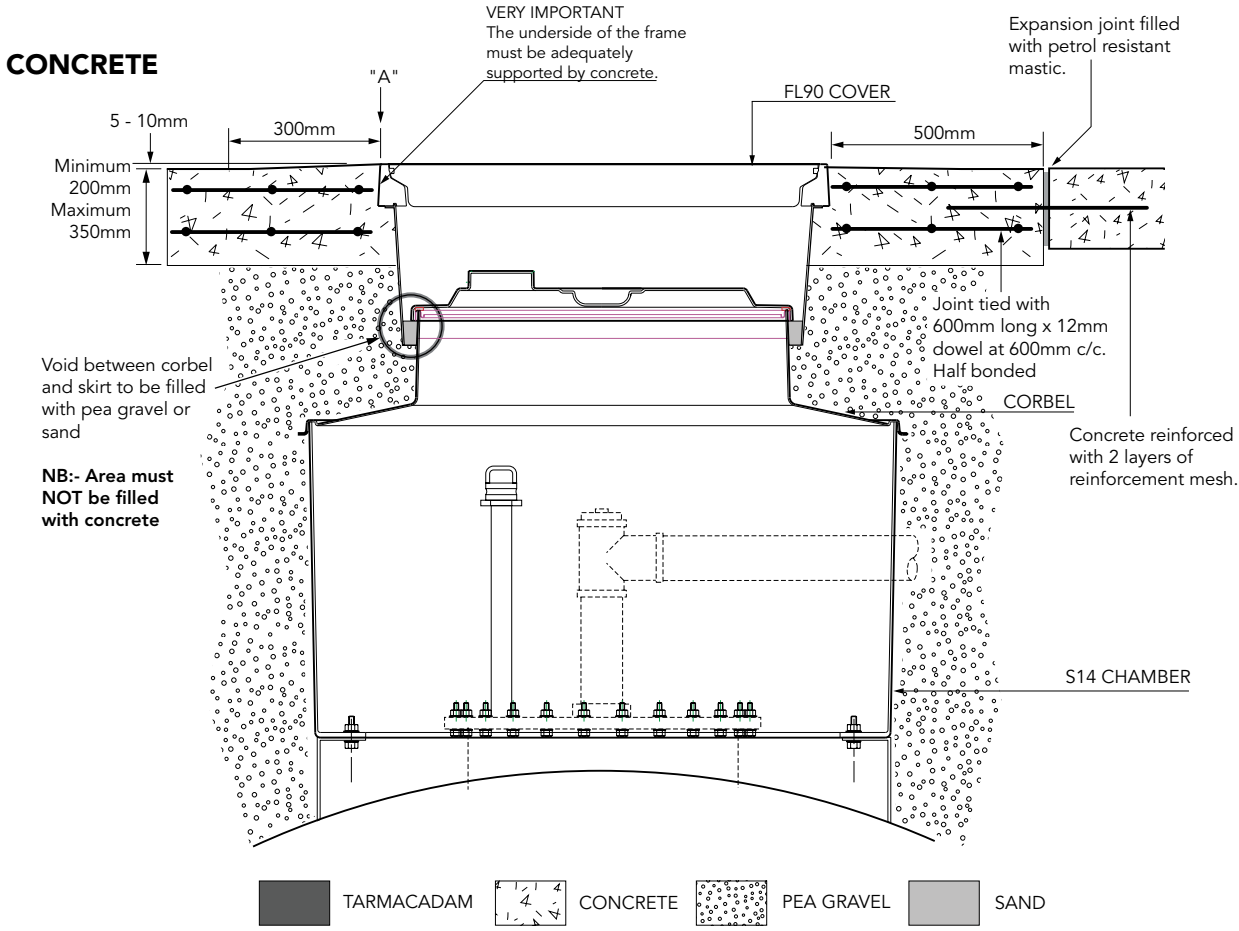

**ALTERNATIVE INSTALLATION ADVICE**

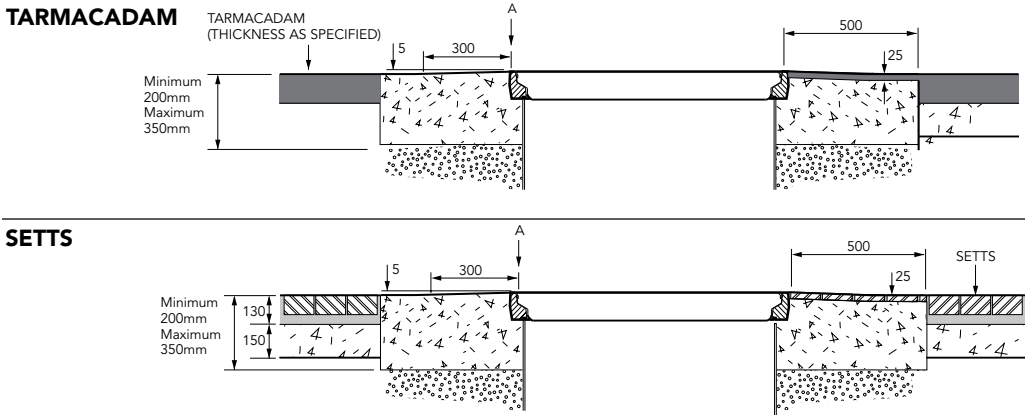

1.4m dia. chamber, sealed corbel with a height adjustable skirt, watertight lid, 900mm flat sealed cover and frame. Exxon Mobil European Tank Chamber.

For reference purposes only. This drawing is not a specification. Order against product code only. To enable continuous improvement of our products, the designs and specifications are subject to change without notice.

