

1.4m diameter stackable bolted base chamber, corbel, non-structural internal lid, adjustable height skirt, 900mm diameter watertight flat sealed cover and frame.

For reference purposes only. This drawing is not a specification. Order against product code only. To enable continuous improvement of our products, the designs and specifications are subject to change without notice.

FIBRELITE 
PART OF OPW A DOVER COMPANY

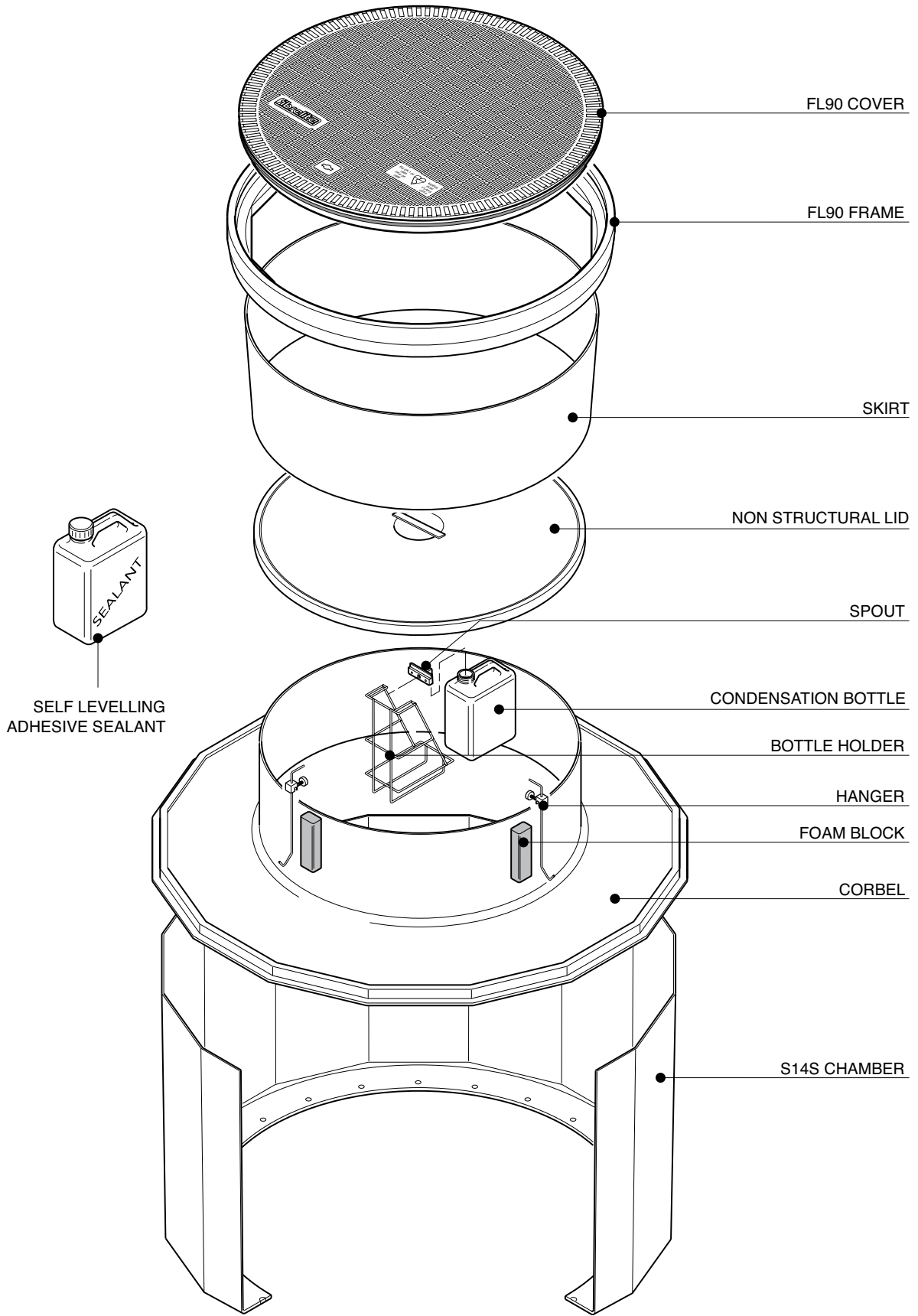

1.4m diameter stackable bolted base chamber, corbel, non-structural internal lid, adjustable height skirt, 900mm diameter watertight flat sealed cover and frame.

For reference purposes only. This drawing is not a specification. Order against product code only. To enable continuous improvement of our products, the designs and specifications are subject to change without notice.



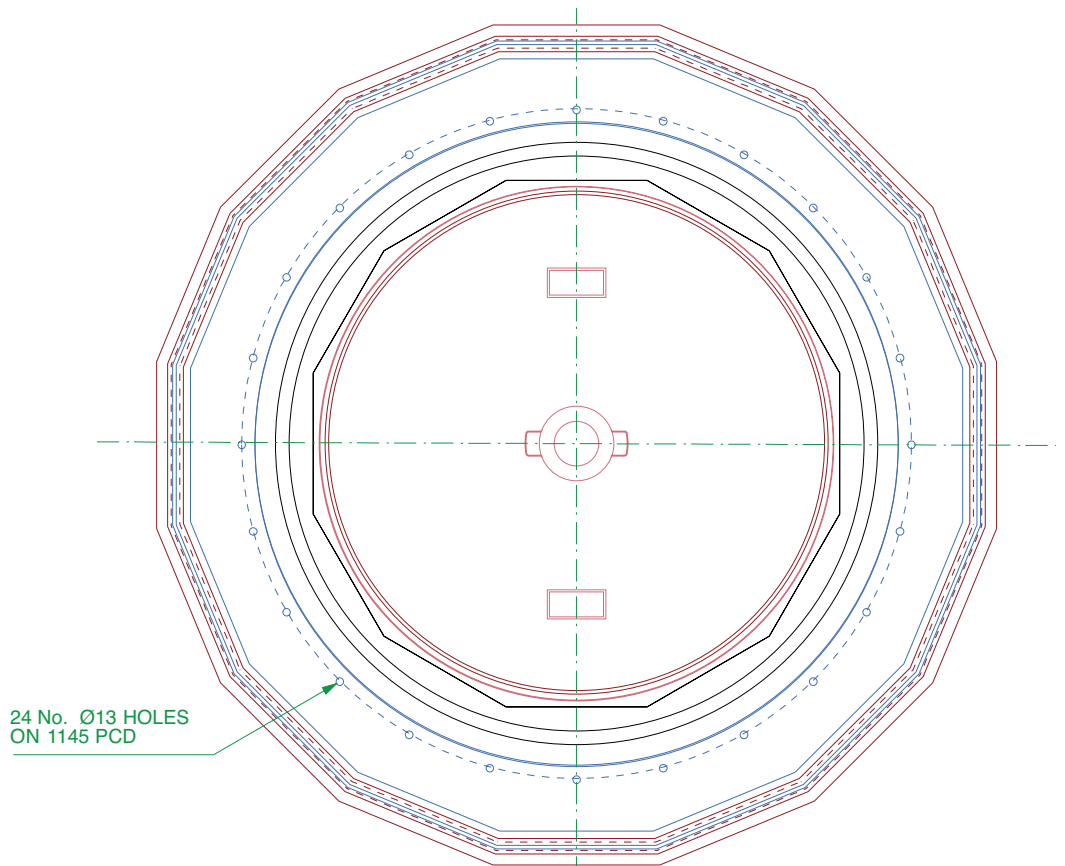

24 No. Ø13 HOLES
ON 1145 PCD

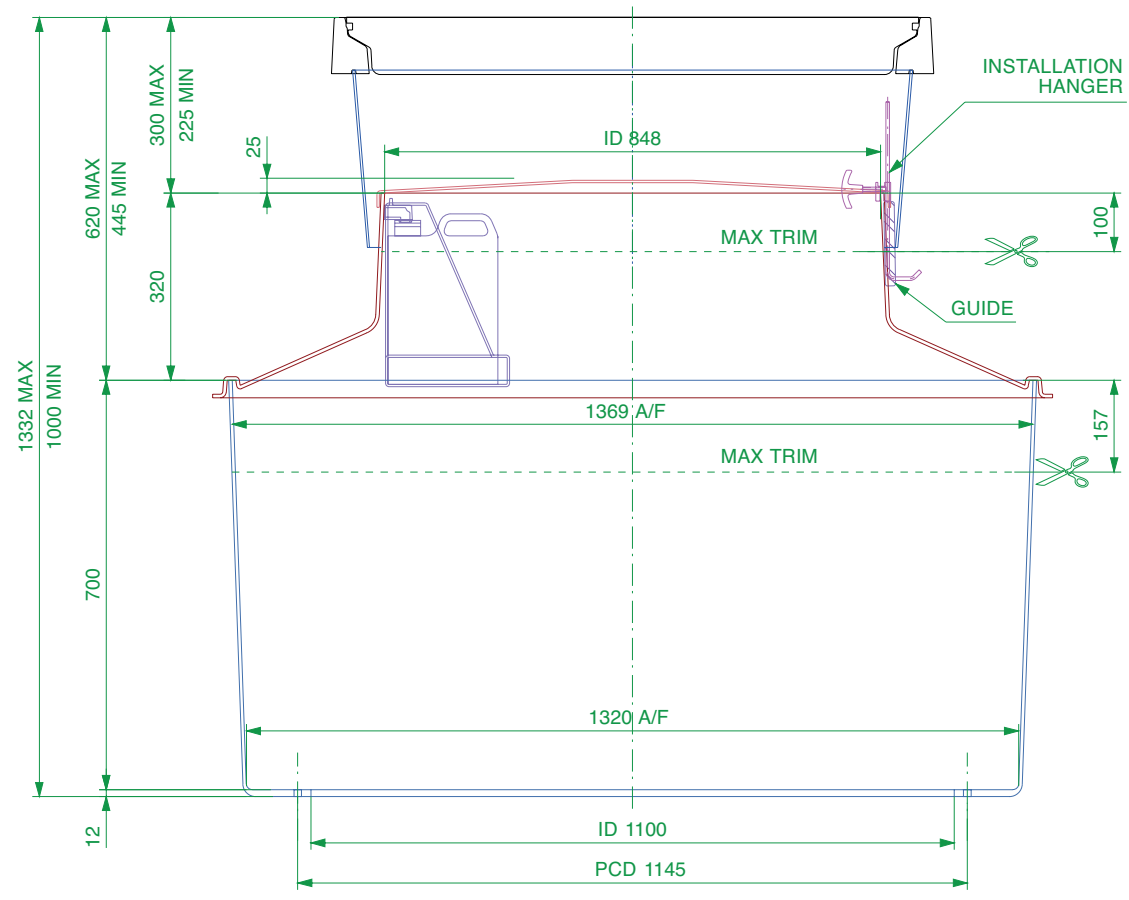

1.4m diameter stackable bolted base chamber, corbel, non-structural internal lid, adjustable height skirt, 900mm diameter watertight flat sealed cover and frame.

For reference purposes only. This drawing is not a specification. Order against product code only. To enable continuous improvement of our products, the designs and specifications are subject to change without notice.



VERY IMPORTANT
OUTER EDGE "A" OF FRAME SET 5 - 10MM
ABOVE GENERAL FORECOURT AREA WITH
CONCRETE RAMPED AWAY OVER 300MM.

TYPICAL INSTALLATION

CONCRETE

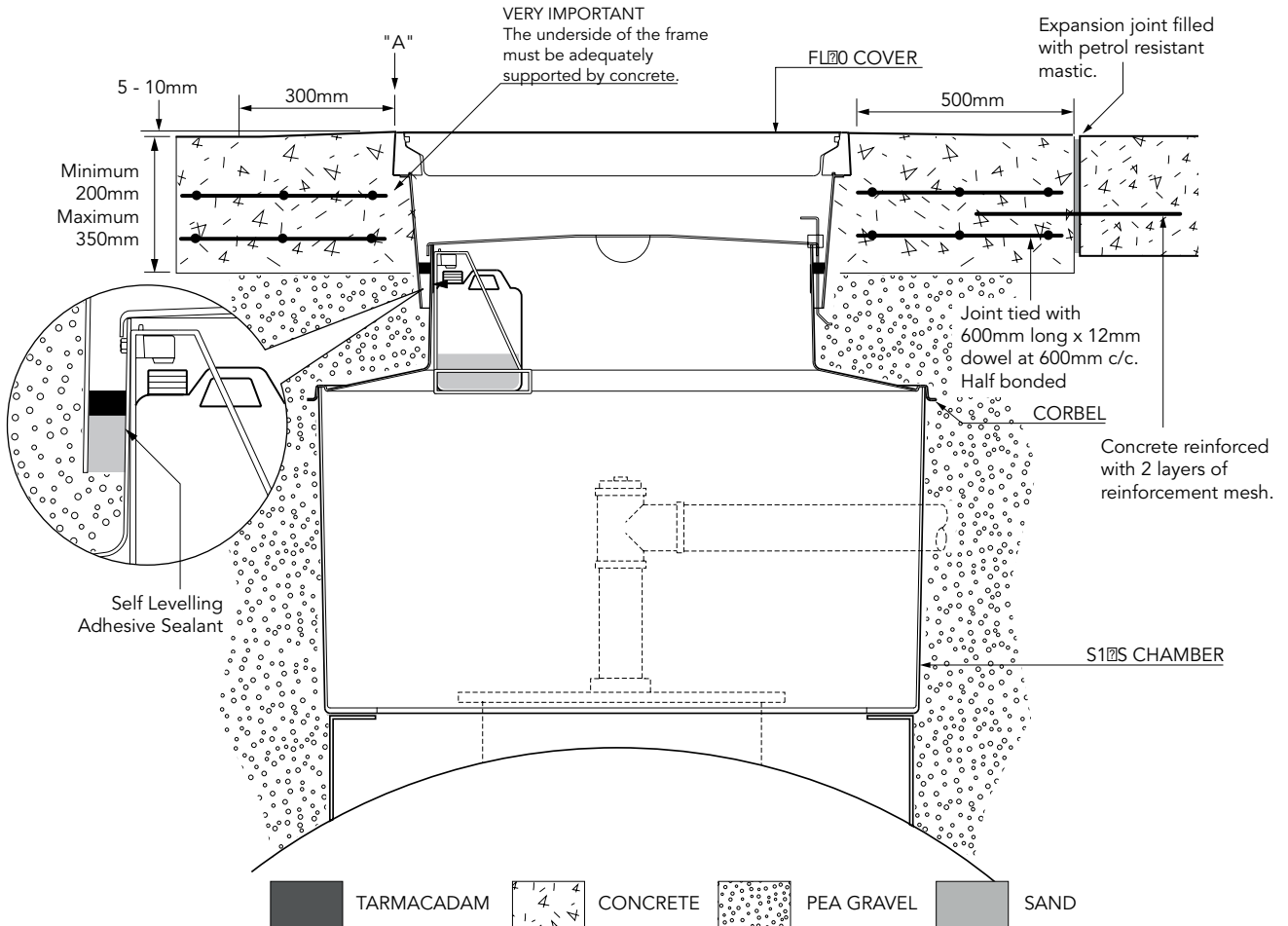

ALTERNATIVE INSTALLATION ADVICE

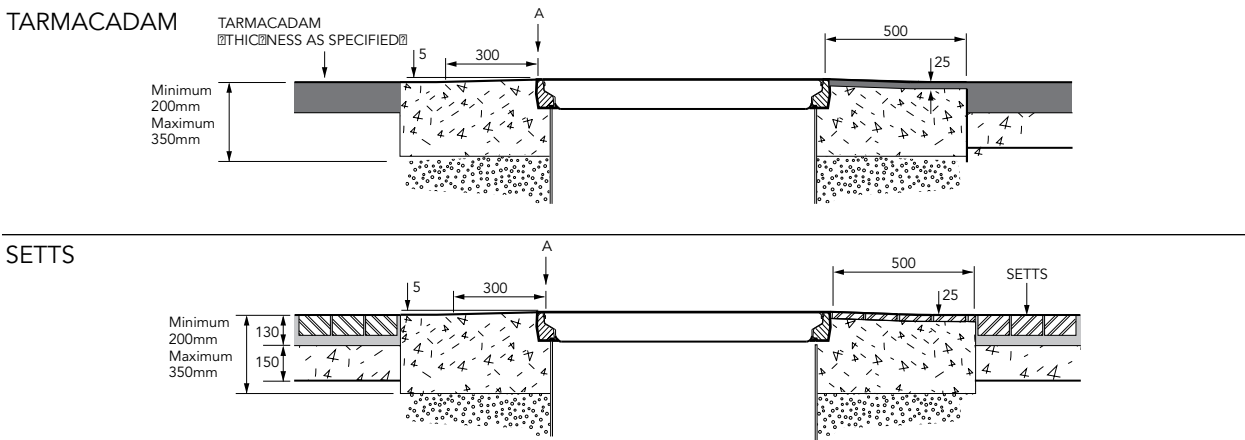

1.4m diameter stackable bolted base chamber, corbel, non-structural internal lid, adjustable height skirt, 900mm diameter watertight flat sealed cover and frame.

For reference purposes only. This drawing is not a specification. Order against product code only. To enable continuous improvement of our products, the designs and specifications are subject to change without notice.

FIBRELITE
 PART OF OPW A DOVER COMPANY