

1.45m diameter sump with collar ring, corbel, internal lid, adjustable height skirt and round 1020mm flat sealed cover with an offset manual dip cover and frame.

For reference purposes only. This drawing is not a specification. Order against product code only. To enable continuous improvement of our products, the designs and specifications are subject to change without notice.

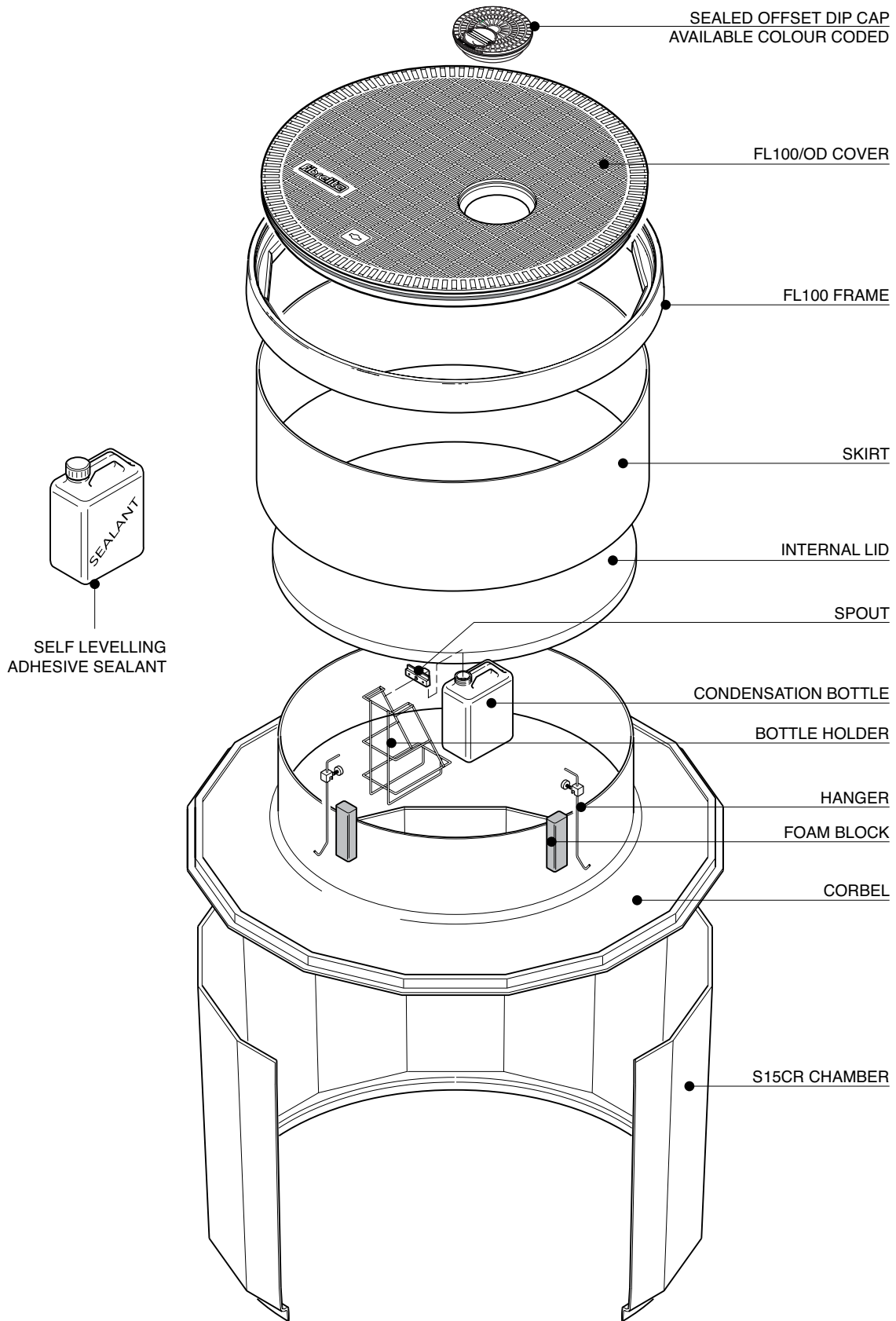

1.45m diameter sump with collar ring, corbel, internal lid, adjustable height skirt and round 1020mm flat sealed cover with an offset manual dip cover and frame.

For reference purposes only. This drawing is not a specification. Order against product code only. To enable continuous improvement of our products, the designs and specifications are subject to change without notice.

**FIBRELITE**   
PART OF OPW A  COMPANY

**VERY IMPORTANT**  
 OUTER EDGE "A" OF FRAME SET 5 - 10MM  
 ABOVE GENERAL FORECOURT AREA WITH  
 CONCRETE RAMPED AWAY OVER 300MM.

**TYPICAL INSTALLATION**

**CONCRETE**

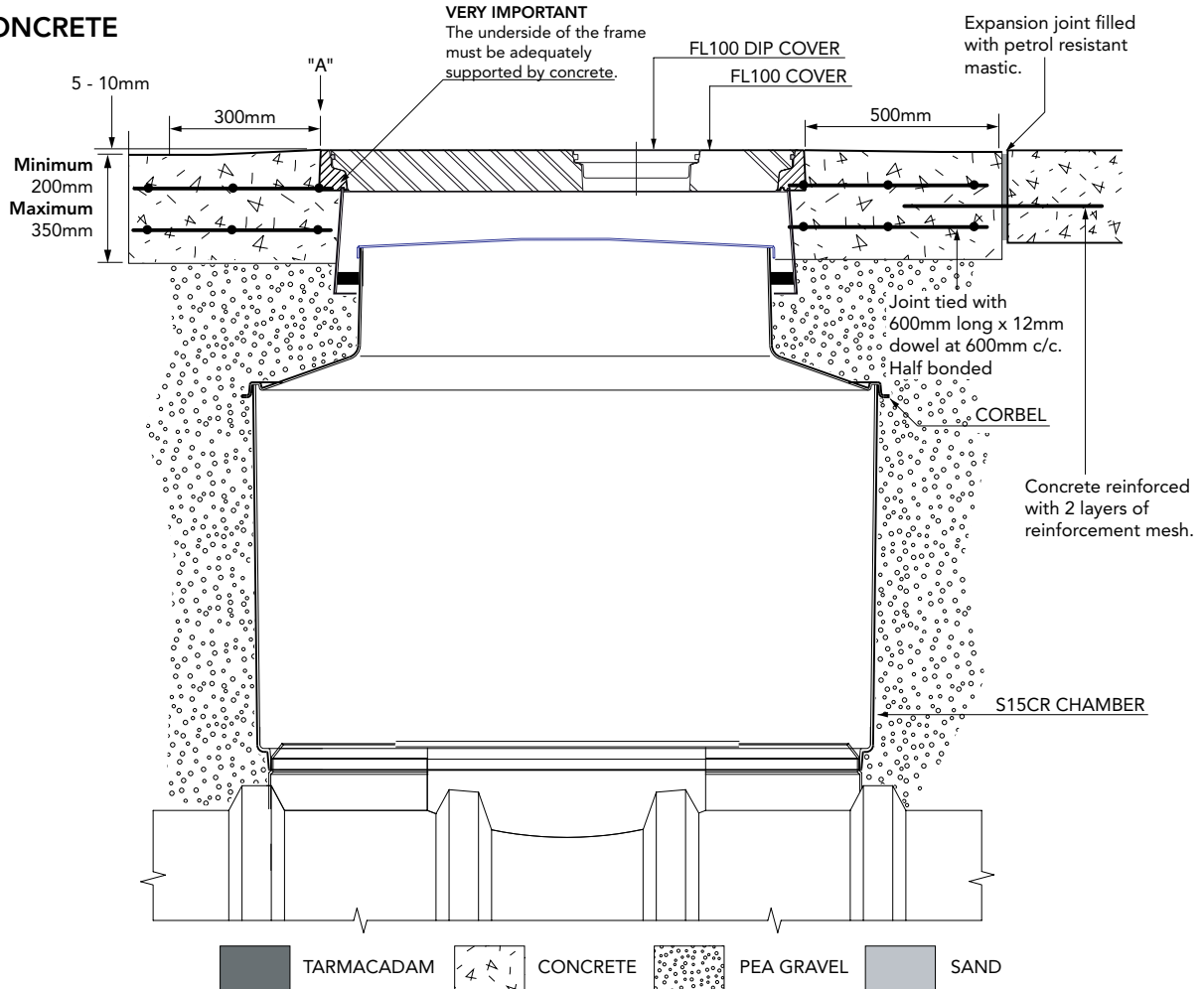

**ALTERNATIVE INSTALLATION ADVICE**

**TARMACADAM**

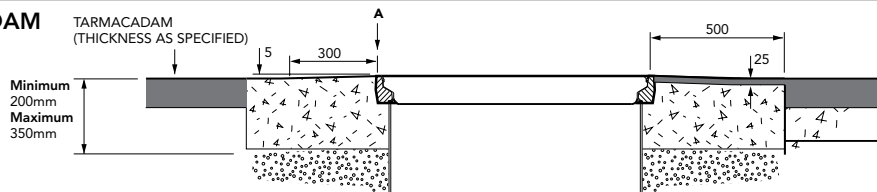

**SETTS**

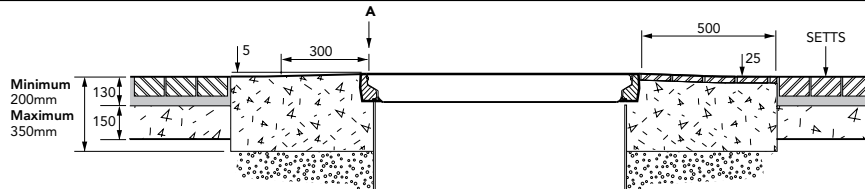

1.45m diameter sump with collar ring, corbel, internal lid, adjustable height skirt and round 1020mm flat sealed cover with an offset manual dip cover and frame.

For reference purposes only. This drawing is not a specification. Order against product code only. To enable continuous improvement of our products, the designs and specifications are subject to change without notice.



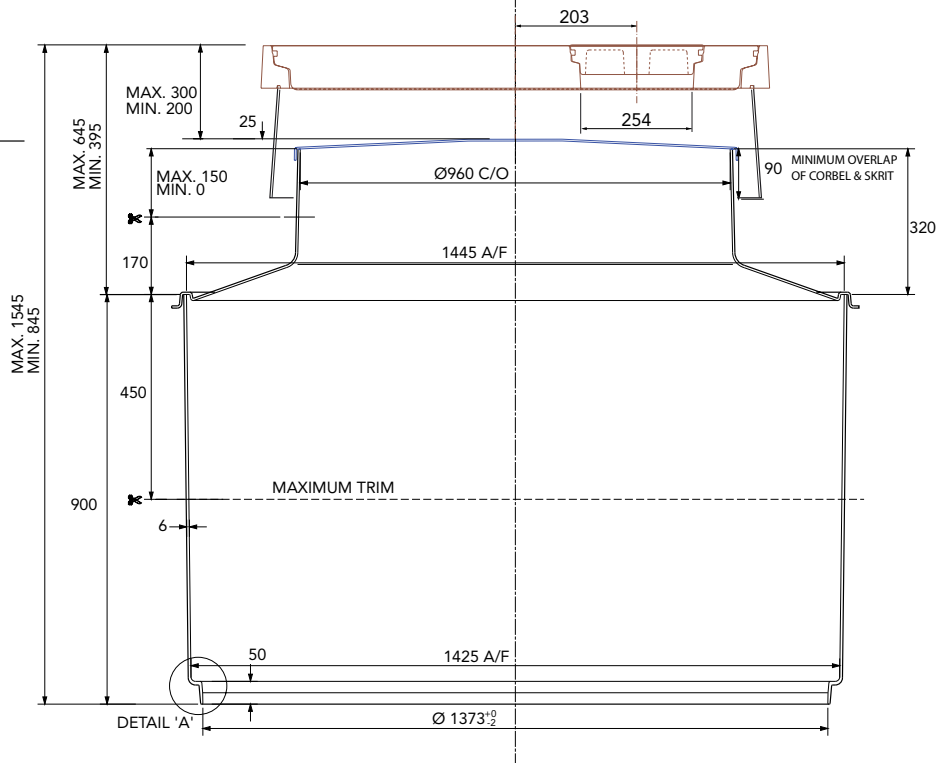
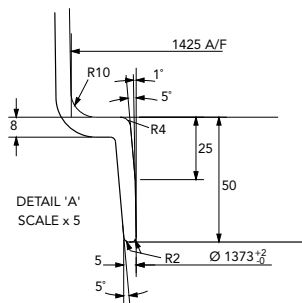
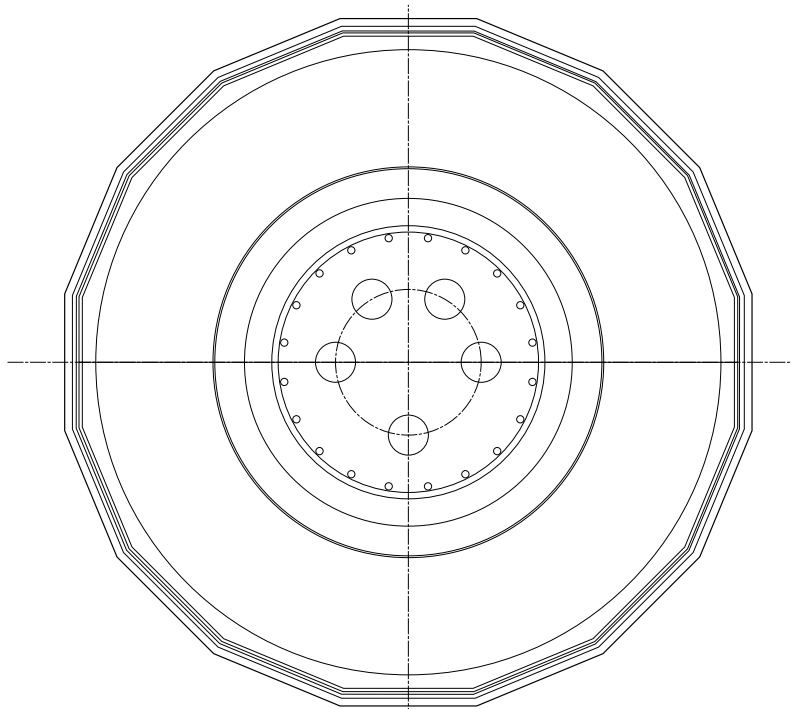
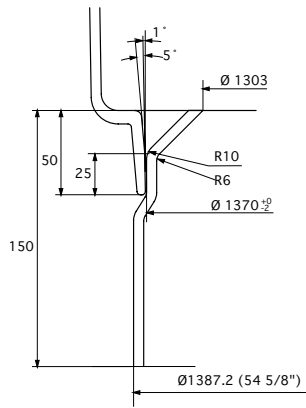

1.45m diameter sump with collar ring, corbel, internal lid, adjustable height skirt and round 1020mm flat sealed cover with an offset manual dip cover and frame.

For reference purposes only. This drawing is not a specification. Order against product code only. To enable continuous improvement of our products, the designs and specifications are subject to change without notice.

**FIBRELITE**   
PART OF OPW A DOVER COMPANY