

1.45m diameter sump with collar ring, corbel, adjustable height skirt and round 1020mm flat sealed cover and frame.

For reference purposes only. This drawing is not a specification. Order against product code only. To enable continuous improvement of our products, the designs and specifications are subject to change without notice.

FIBRELITE 
PART OF OPW A DOVER COMPANY

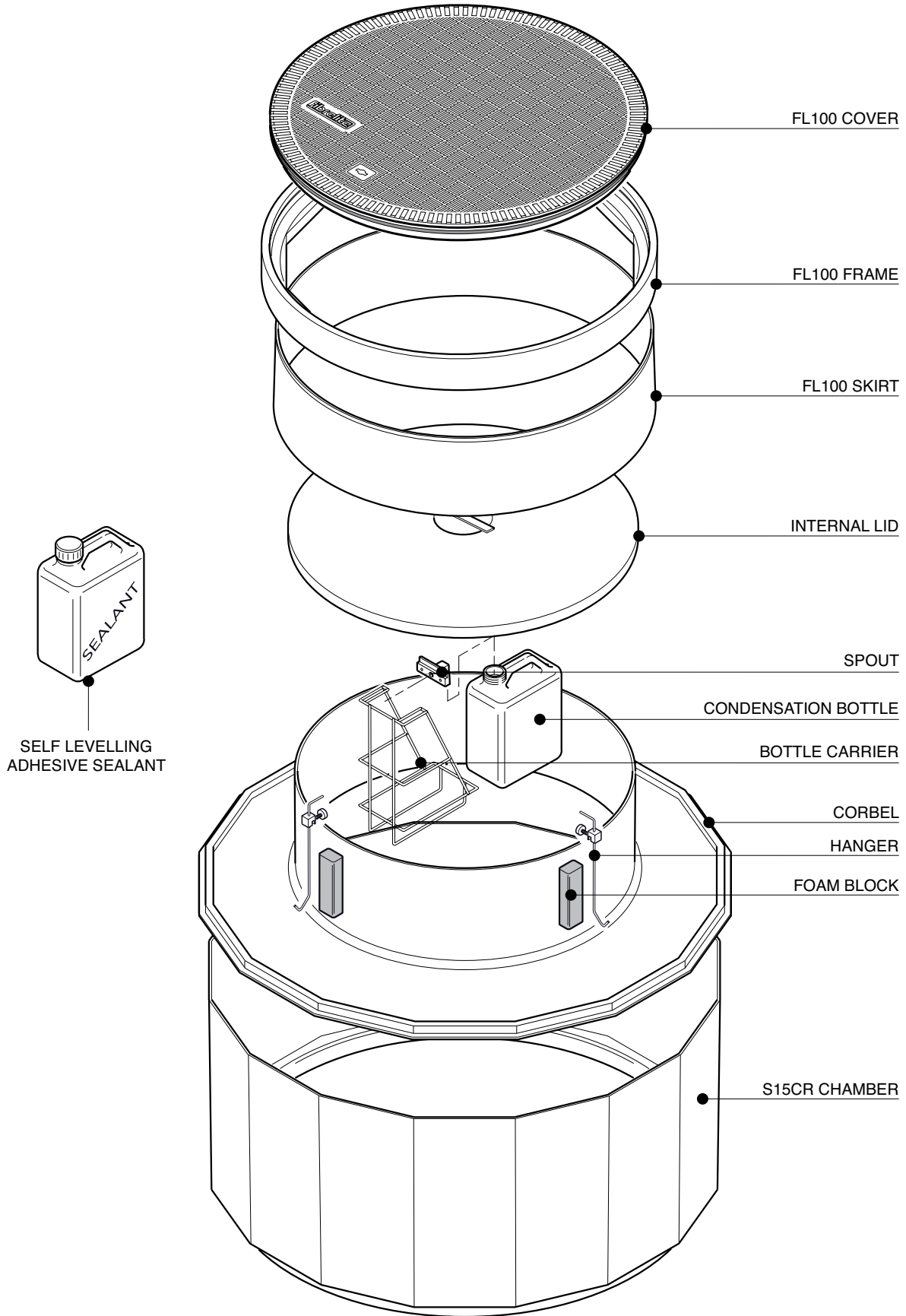

1.45m diameter sump with collar ring, corbel, adjustable height skirt and round 1020mm flat sealed cover and frame.

For reference purposes only. This drawing is not a specification. Order against product code only. To enable continuous improvement of our products, the designs and specifications are subject to change without notice.

FIBRELITE 
PART OF OPW A DOWDER COMPANY

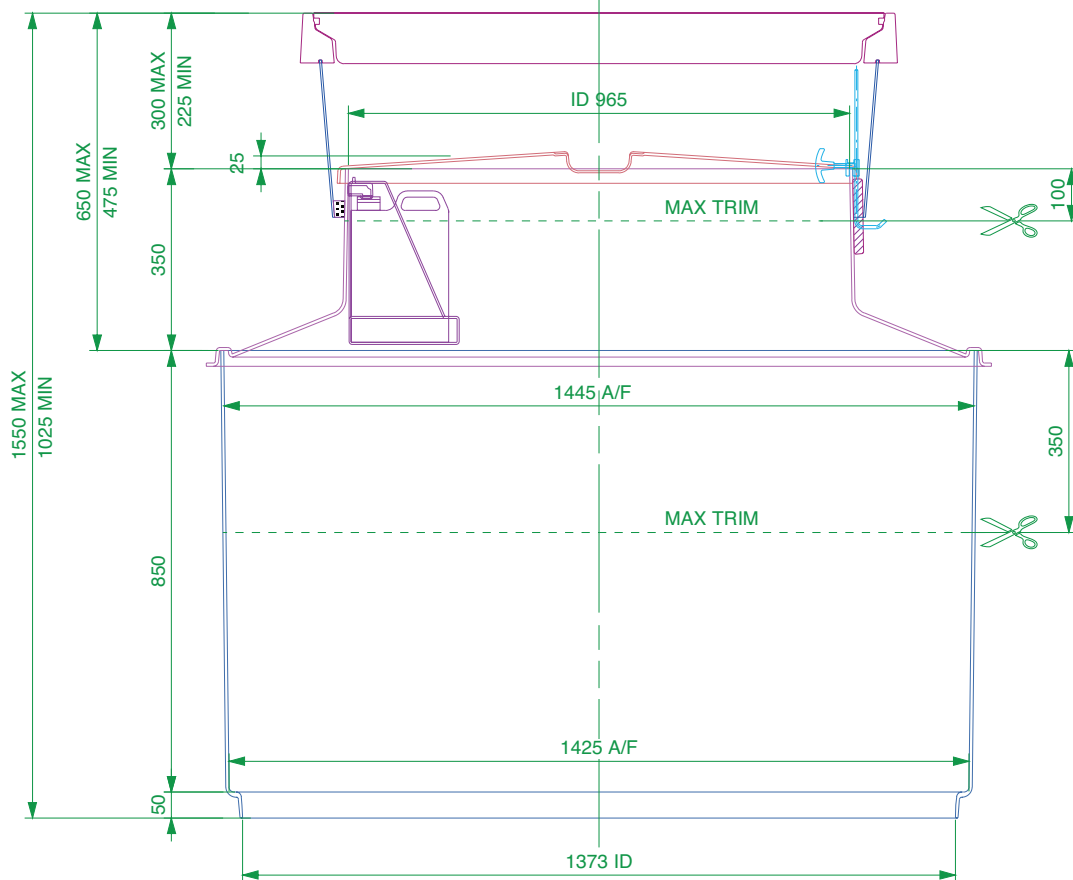
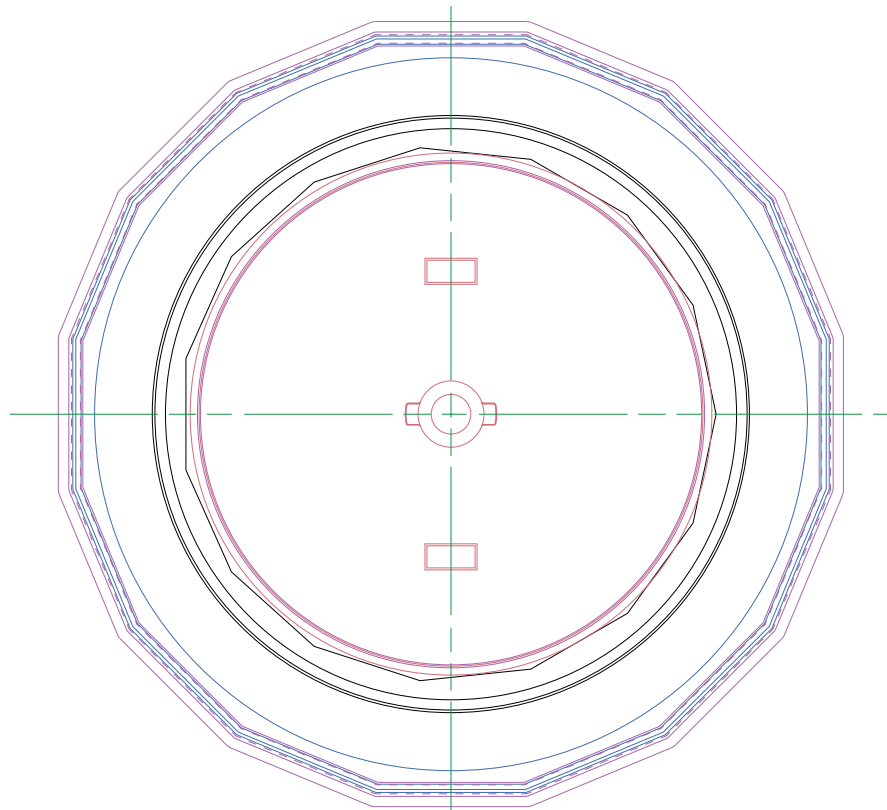

1.45m diameter sump with collar ring, corbel, adjustable height skirt and round 1020mm flat sealed cover and frame.

For reference purposes only. This drawing is not a specification. Order against product code only. To enable continuous improvement of our products, the designs and specifications are subject to change without notice.

FIBRELITE 
PART OF OPW A DOVER COMPANY

VERY IMPORTANT
 OUTER EDGE "A" OF FRAME SET 5 - 10MM
 ABOVE GENERAL FORECOURT AREA WITH
 CONCRETE RAMPED AWAY OVER 300MM.

TYPICAL INSTALLATION

CONCRETE

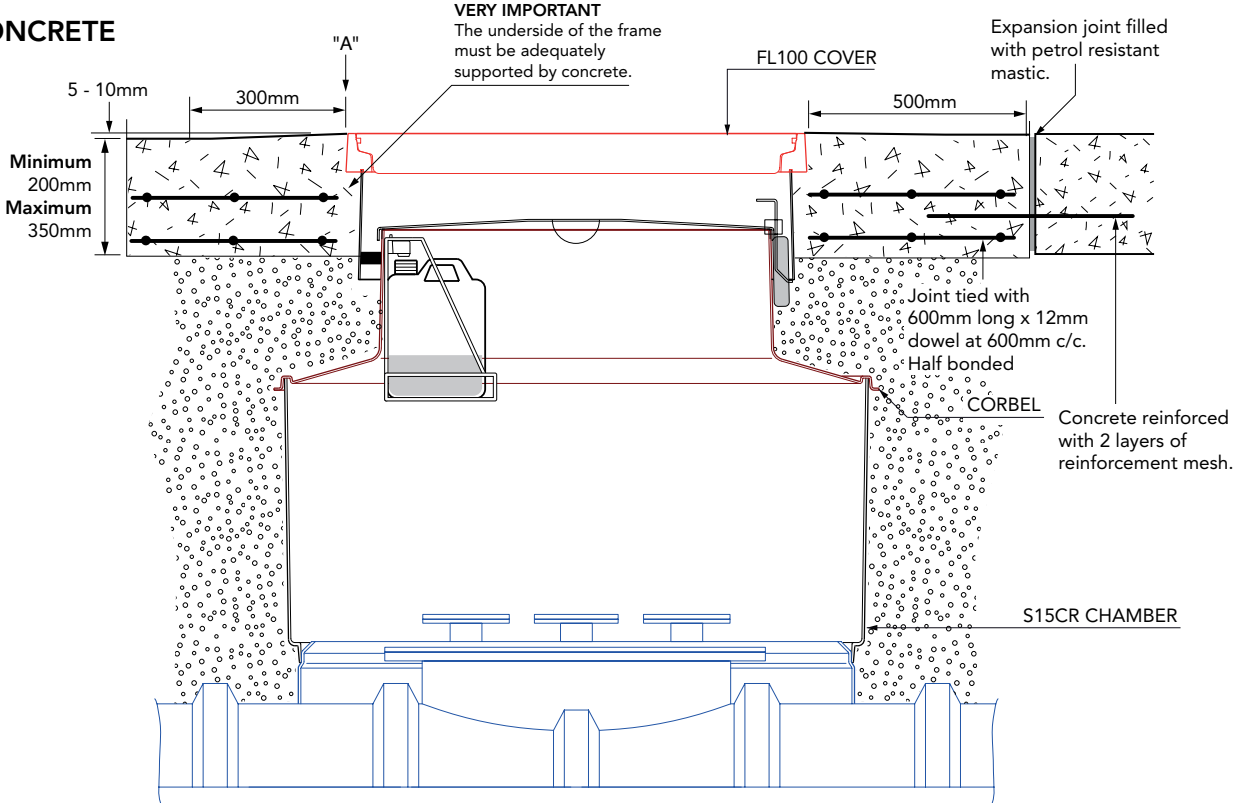

ALTERNATIVE INSTALLATION ADVICE

TARMACADAM

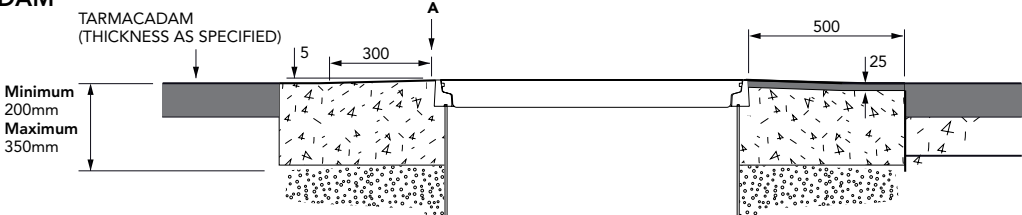

SETTS

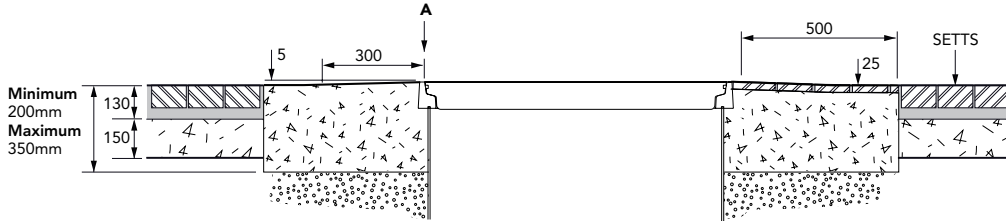

1.45m diameter sump with collar ring, corbel, adjustable height skirt and round 1020mm flat sealed cover and frame.

For reference purposes only. This drawing is not a specification. Order against product code only. To enable continuous improvement of our products, the designs and specifications are subject to change without notice.

