

1.45m diameter sump with collar ring, corbel, spill platform to fit OPW spill bucket, adjustable height skirt and round 900mm flat sealed cover with central fill cover and frame.

For reference purposes only. This drawing is not a specification. Order against product code only. To enable continuous improvement of our products, the designs and specifications are subject to change without notice.

**FIBRELITE**   
PART OF OPW A DOVER COMPANY

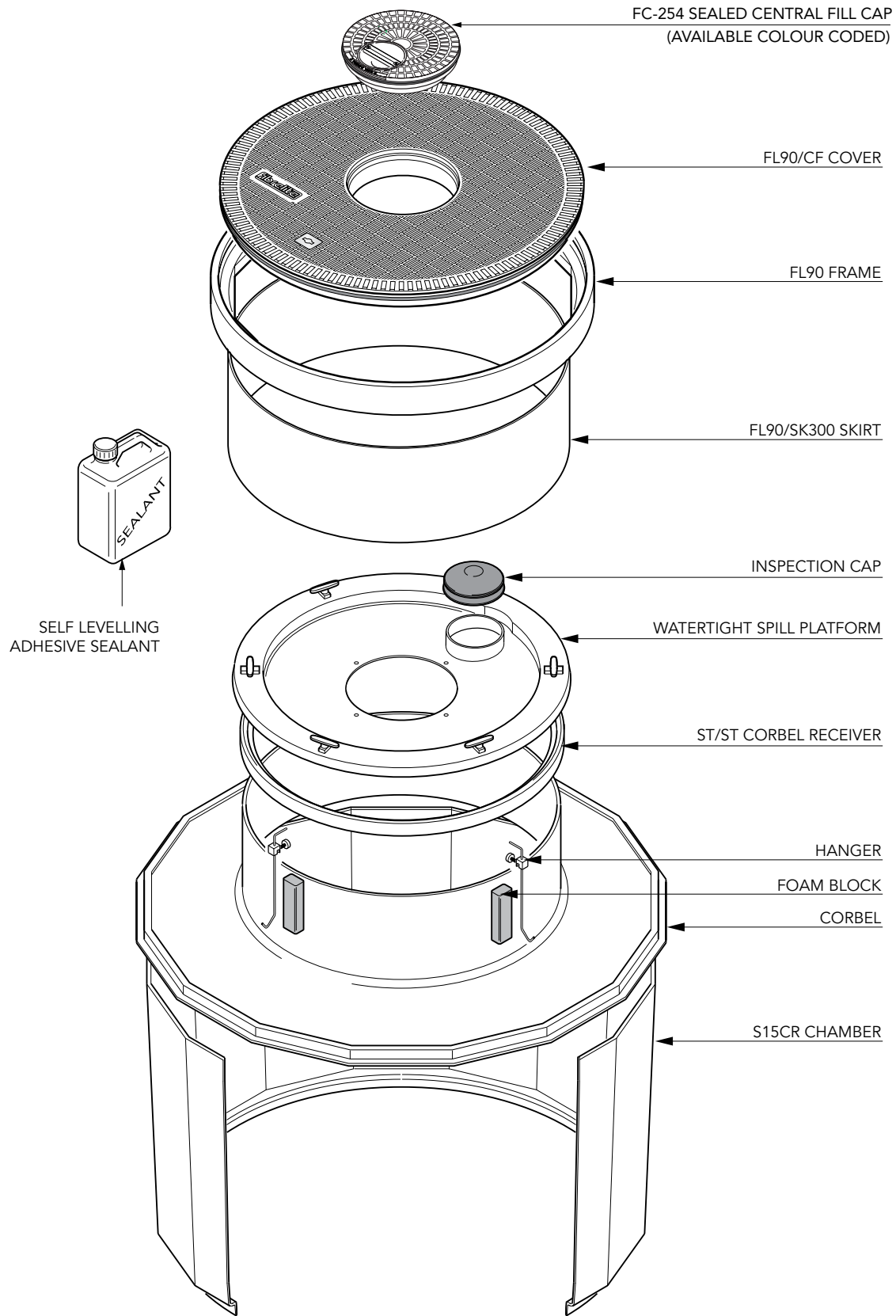

1.45m diameter sump with collar ring, corbel, spill platform to fit OPW spill bucket, adjustable height skirt and round 900mm flat sealed cover with central fill cover and frame.

For reference purposes only. This drawing is not a specification. Order against product code only. To enable continuous improvement of our products, the designs and specifications are subject to change without notice.

**FIBRELITE**   
PART OF OPW A DOWDER COMPANY

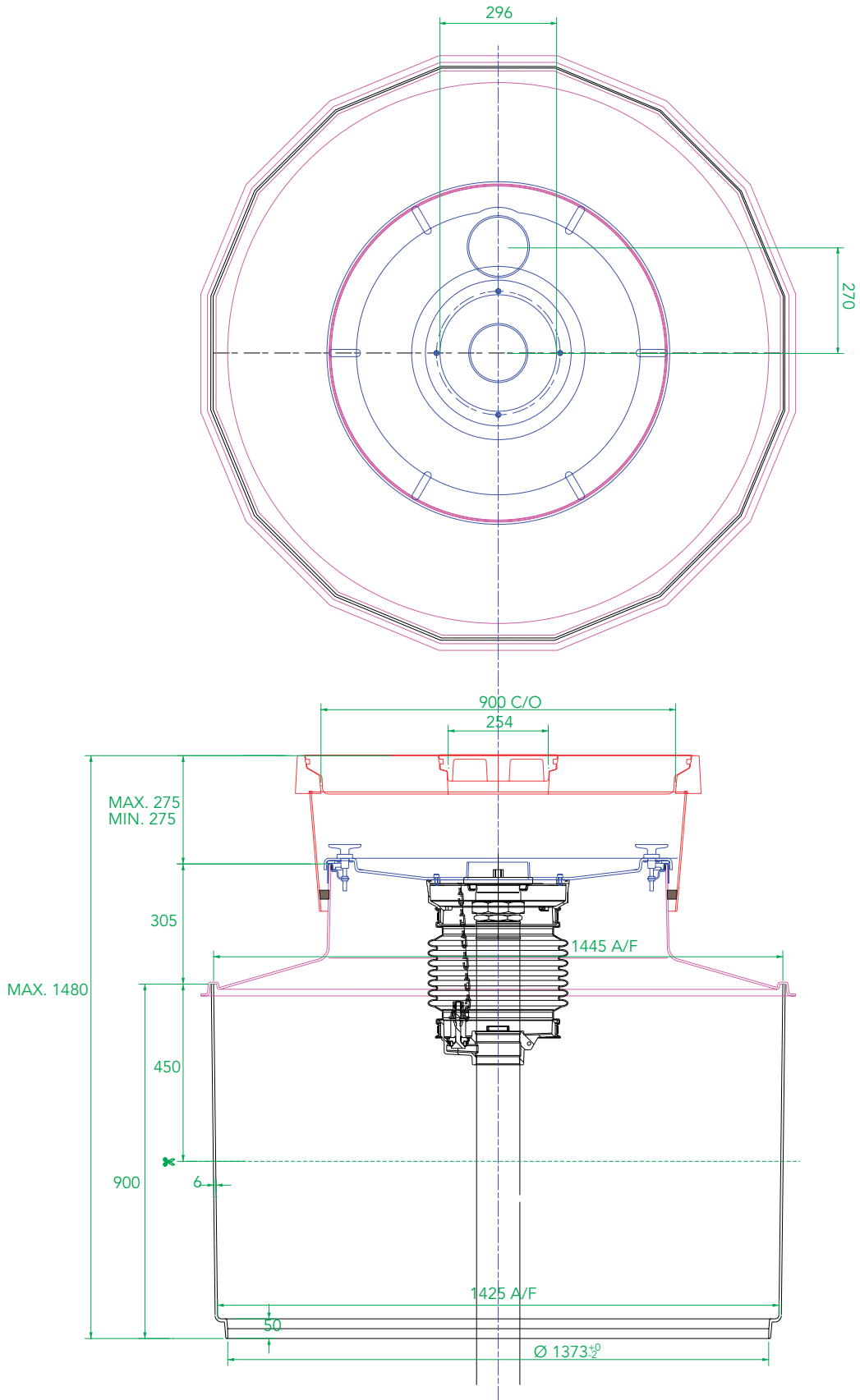

1.45m diameter sump with collar ring, corbel, spill platform to fit OPW spill bucket, adjustable height skirt and round 900mm flat sealed cover with central fill cover and frame.

For reference purposes only. This drawing is not a specification. Order against product code only. To enable continuous improvement of our products, the designs and specifications are subject to change without notice.

**FIBRELITE**   
PART OF OPW A DOVER COMPANY

**! VERY IMPORTANT SET OUTER EDGE 'A' OF FRAME 25MM ABOVE GENERAL FORECOURT AREA RAMPED AWAY OVER 450MM !**

**TYPICAL INSTALLATION**

CONCRETE

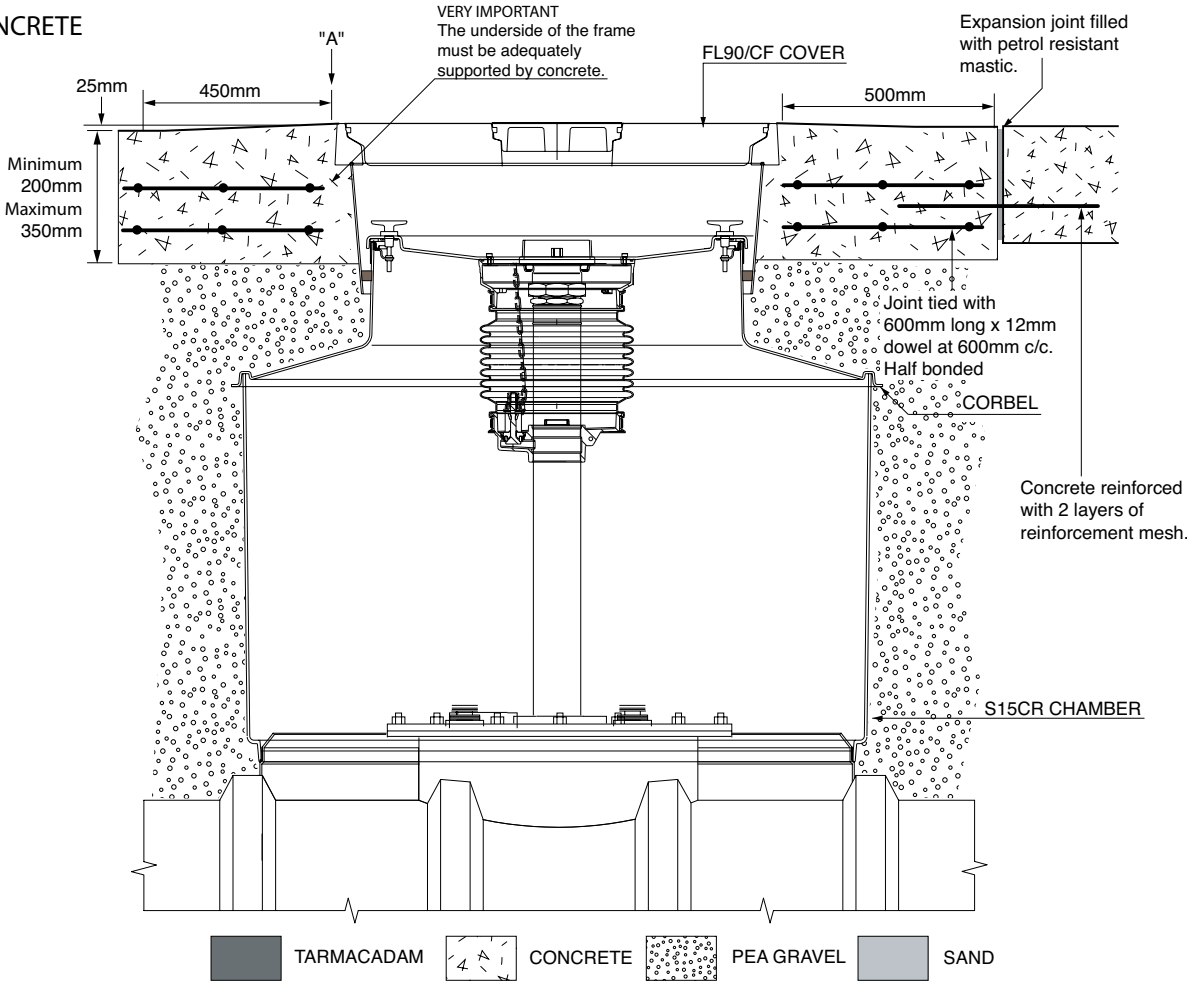

1.45m diameter sump with collar ring, corbel, spill platform to fit OPW spill bucket, adjustable height skirt and round 900mm flat sealed cover with central fill cover and frame.

For reference purposes only. This drawing is not a specification. Order against product code only. To enable continuous improvement of our products, the designs and specifications are subject to change without notice.

**FIBRELITE**   
PART OF OPW A DOVER COMPANY