

1.2m diameter bolted base chamber, corbel, internal lid with a height adjustable skirt and round 900mm flat sealed cover with a centre dip port. Includes sealkit with condensation bottle and fixing kit. Round tank flange. Remote Fill

For reference purposes only. This drawing is not a specification. Order against product code only. To enable continuous improvement of our products, the designs and specifications are subject to change without notice.

FIBRELITE 
PART OF OPW A DOVER COMPANY

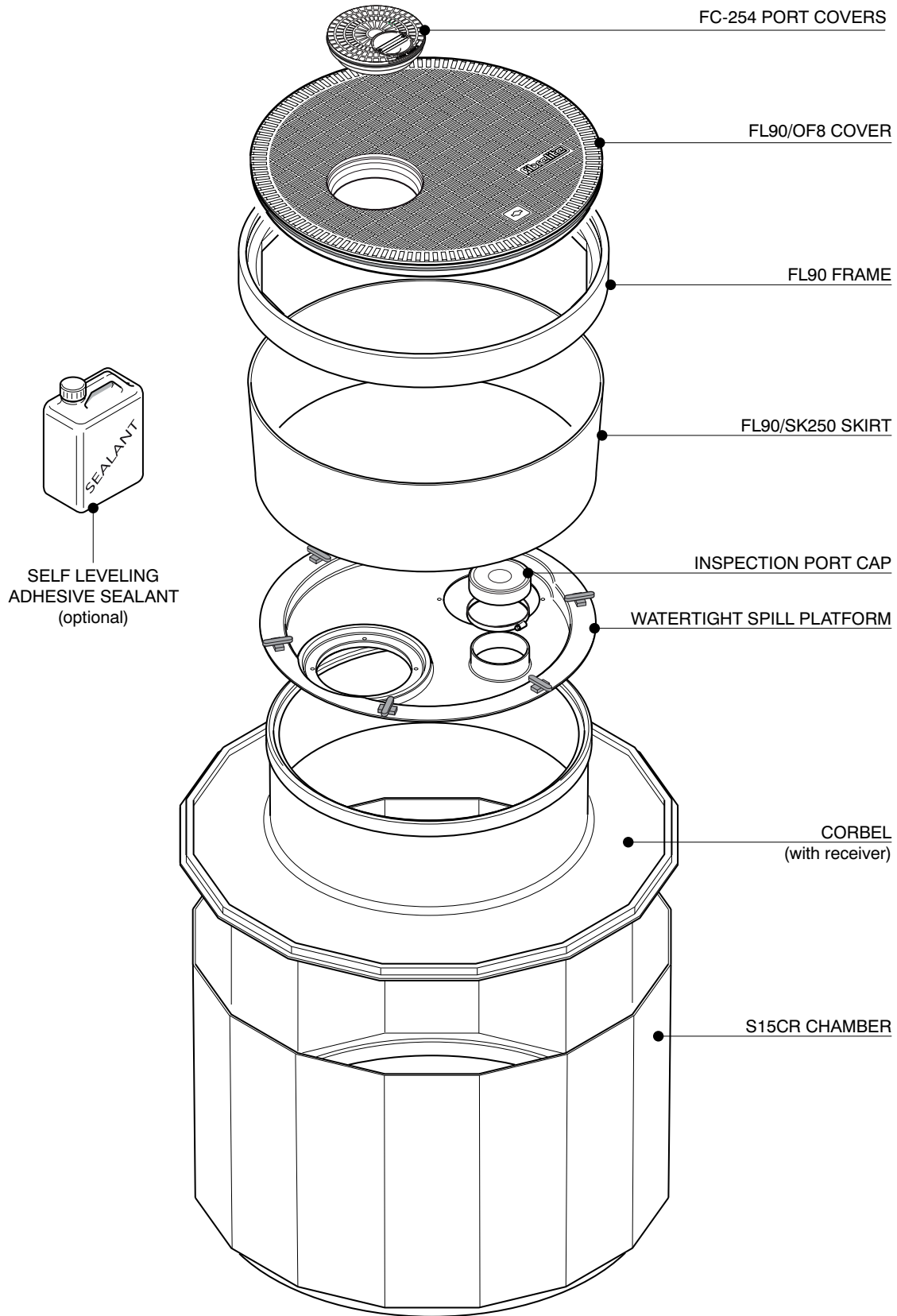

1.2m diameter bolted base chamber, corbel, internal lid with a height adjustable skirt and round 900mm flat sealed cover with a centre dip port. Includes sealkit with condensation bottle and fixing kit. Round tank flange. Remote Fill

For reference purposes only. This drawing is not a specification. Order against product code only. To enable continuous improvement of our products, the designs and specifications are subject to change without notice.

FIBRELITE 
PART OF OPW A DOVER COMPANY

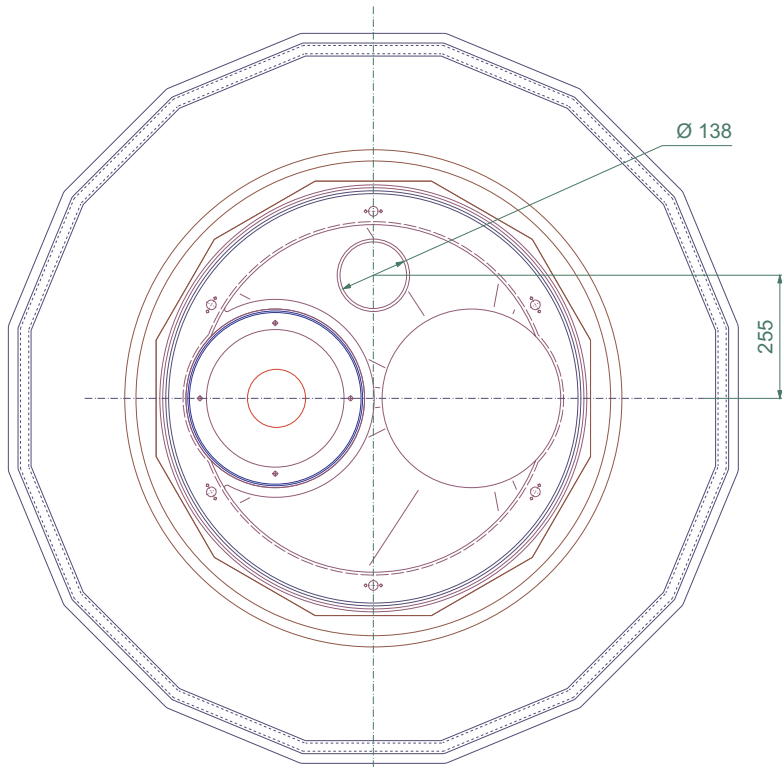

CRITICAL DIMENSION FOR FILL
AND VAPOR ADAPTORS

TOP OF ADAPTOR CAPS OR DRY BREAK
COUPLING MUST BE A MAXIMUM
OF 130mm BELOW GRADE

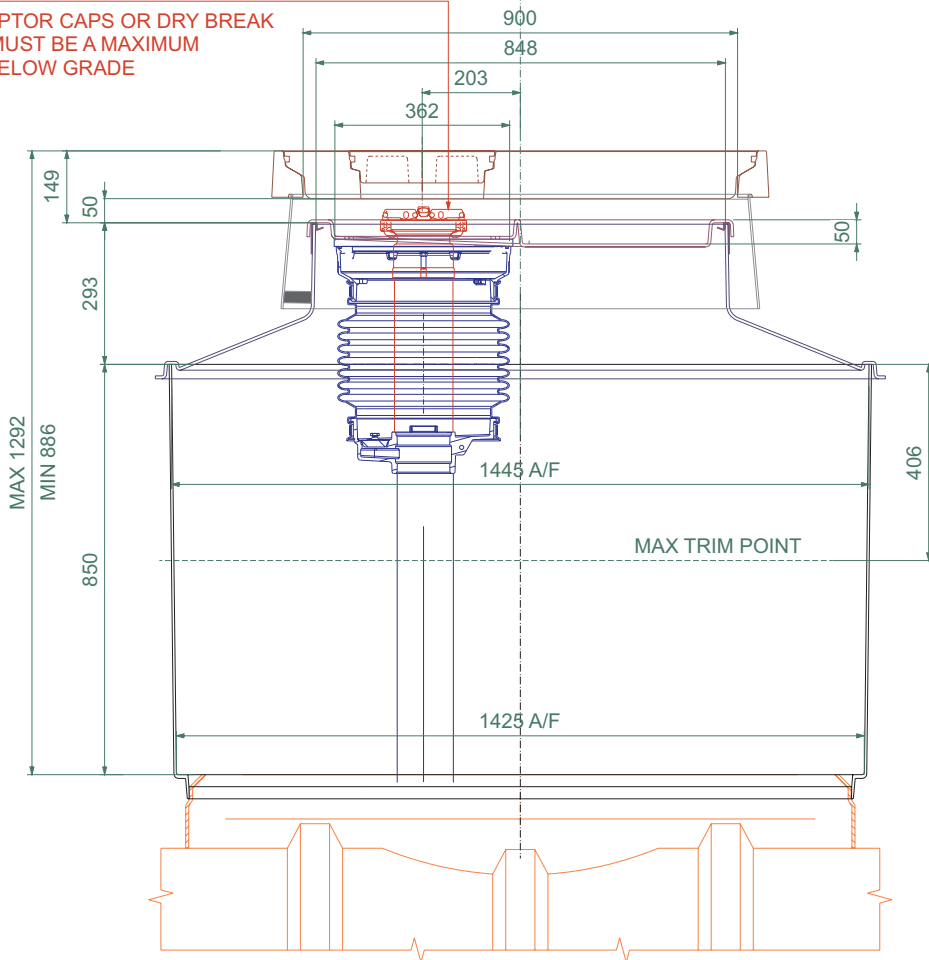

1.2m diameter bolted base chamber, corbel, internal lid with a height adjustable skirt and round 900mm flat sealed cover with a centre dip port. Includes sealkit with condensation bottle and fixing kit. Round tank flange. Remote Fill

For reference purposes only. This drawing is not a specification. Order against product code only. To enable continuous improvement of our products, the designs and specifications are subject to change without notice.

FIBRELITE 
PART OF OPW A DOVER COMPANY

VERY IMPORTANT
 OUTER EDGE "A" OF FRAME SET 25MM
 ABOVE GENERAL FORECOURT AREA WITH
 CONCRETE RAMPED AWAY OVER 450mm."

TYPICAL INSTALLATION

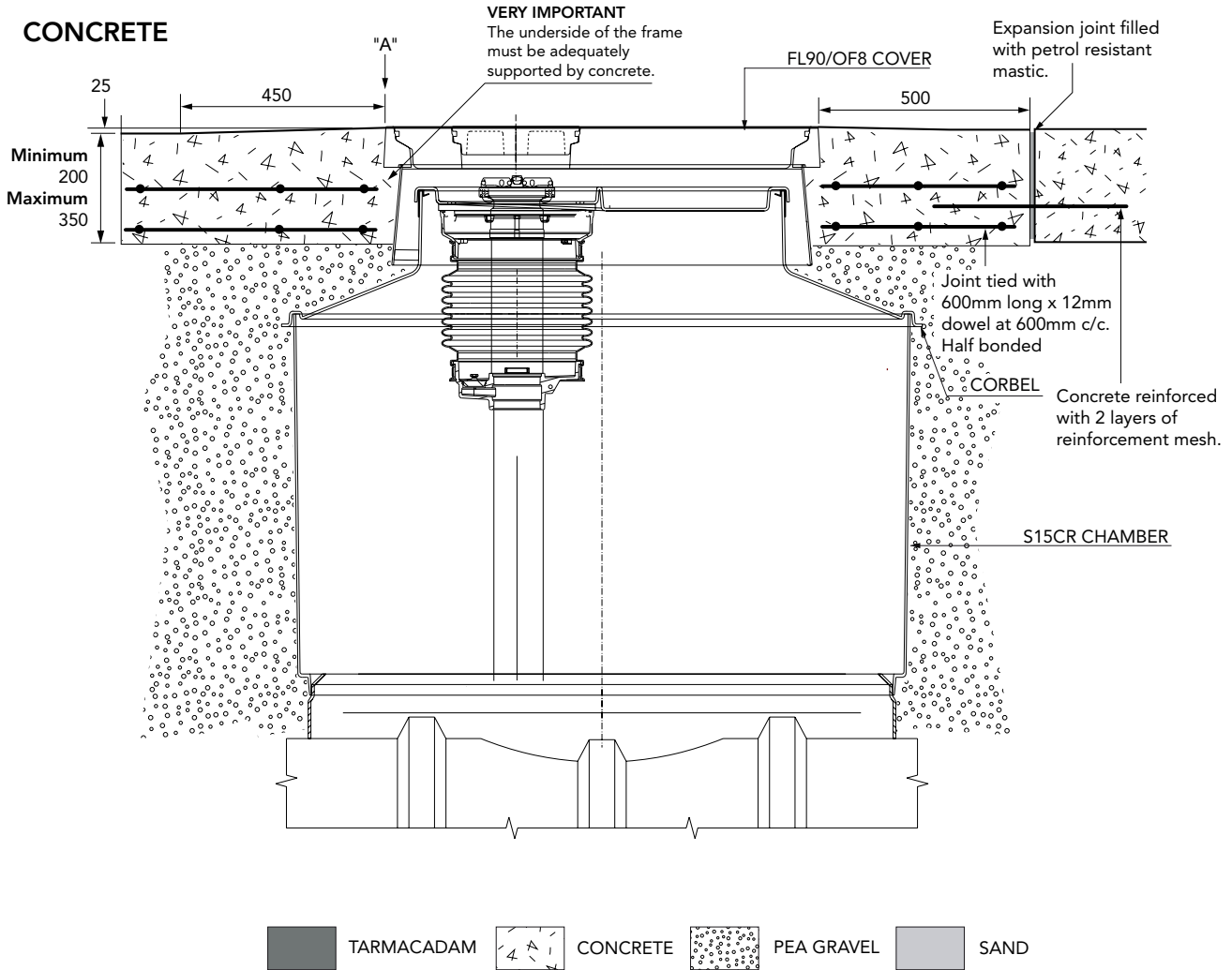

ALTERNATIVE INSTALLATION ADVICE

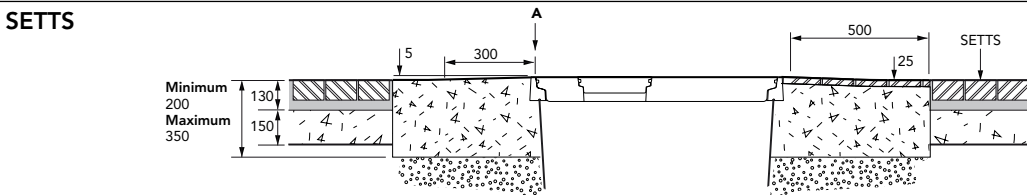
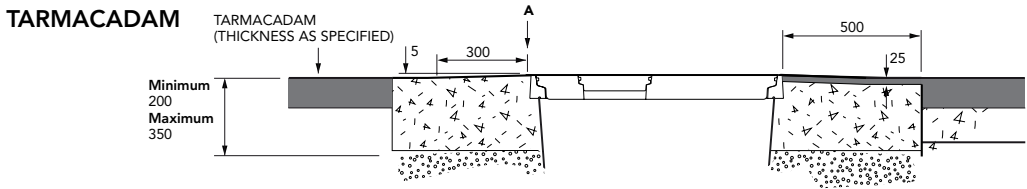

1.2m diameter bolted base chamber, corbel, internal lid with a height adjustable skirt and round 900mm flat sealed cover with a centre dip port. Includes sealkit with condensation bottle and fixing kit. Round tank flange. Remote Fill

For reference purposes only. This drawing is not a specification. Order against product code only. To enable continuous improvement of our products, the designs and specifications are subject to change without notice.

FIBRELITE
 PART OF OPW A DOVER COMPANY