

1.45m diameter sump with collar ring, corbel, internal lid, adjustable height skirt and round 900mm flat sealed cover and frame.

For reference purposes only. This drawing is not a specification. Order against product code only. To enable continuous improvement of our products, the designs and specifications are subject to change without notice.

FIBRELITE 
PART OF OPW A DOVER COMPANY

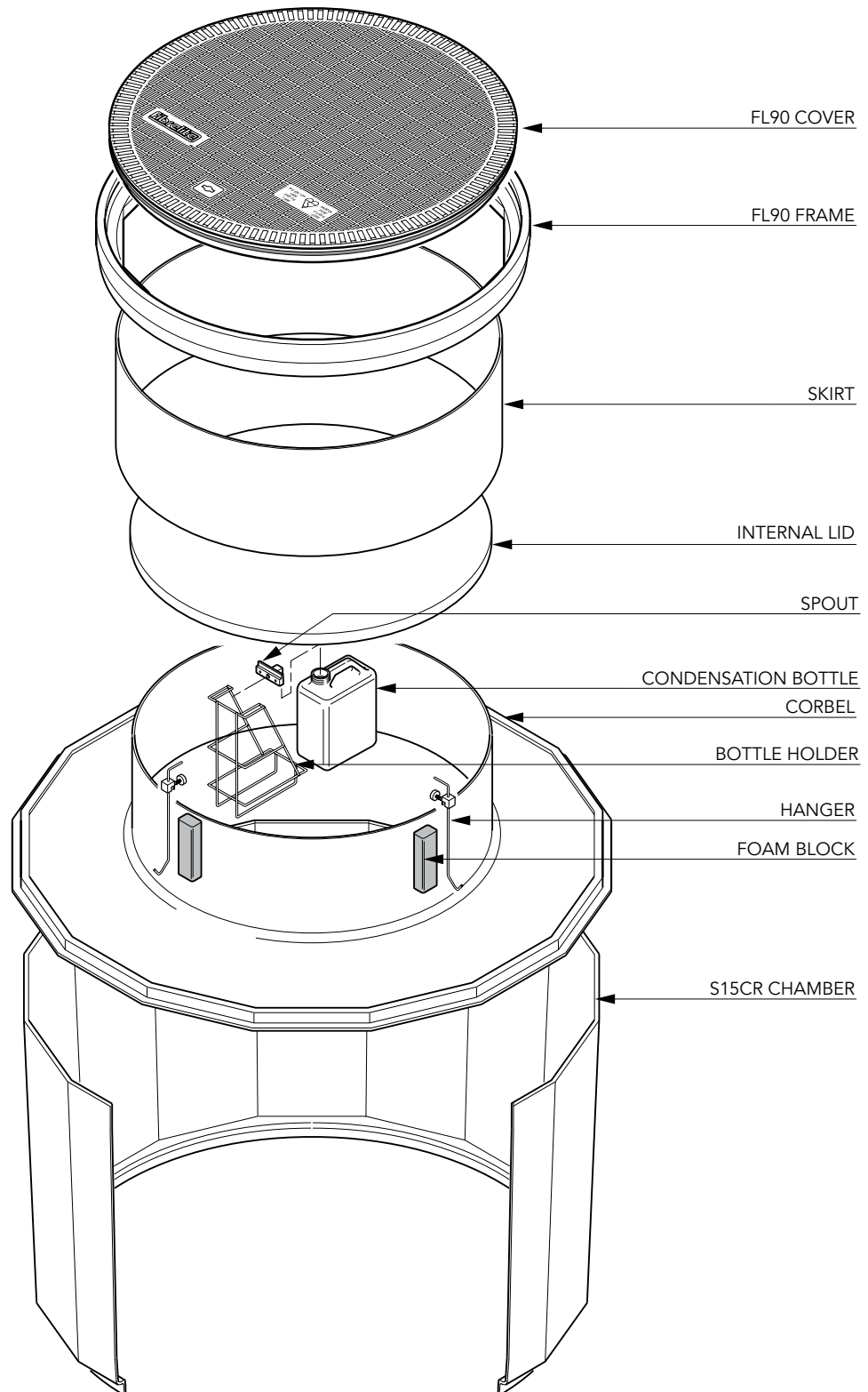
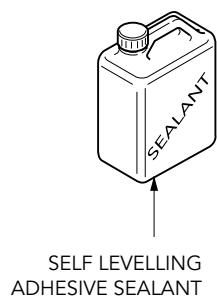

1.45m diameter sump with collar ring, corbel, internal lid, adjustable height skirt and round 900mm flat sealed cover and frame.

For reference purposes only. This drawing is not a specification. Order against product code only. To enable continuous improvement of our products, the designs and specifications are subject to change without notice.

FIBRELITE 
PART OF OPW A DOVER COMPANY

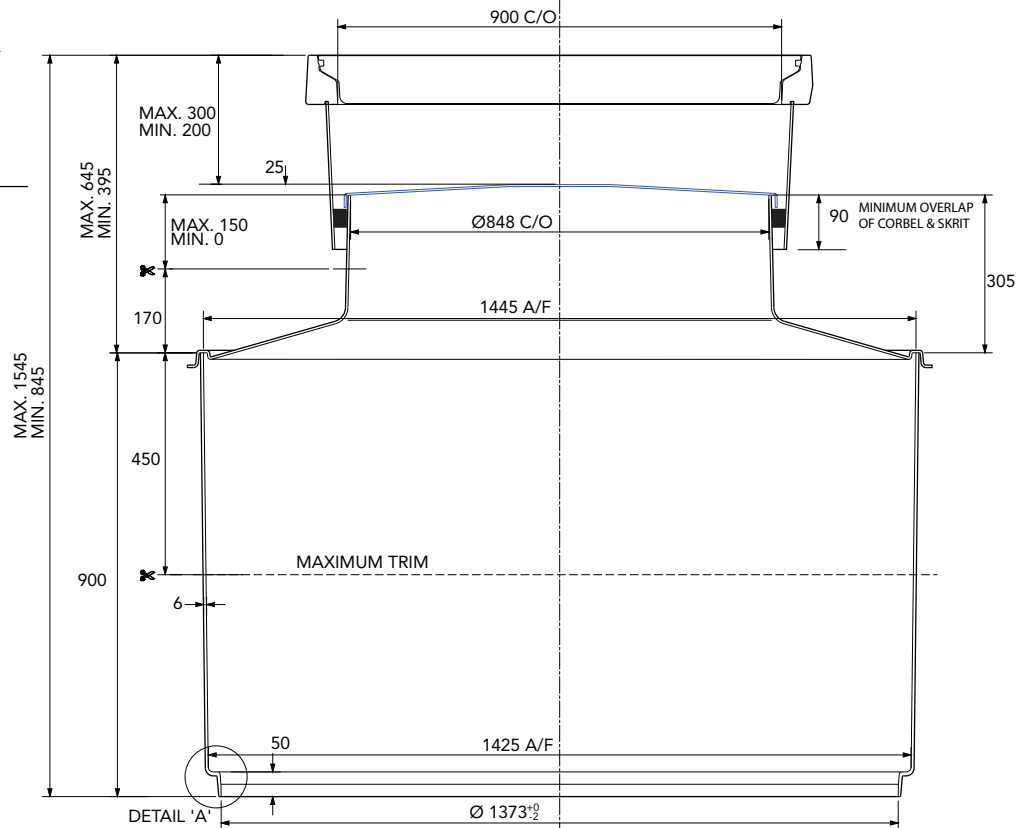
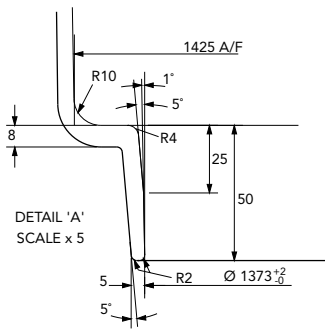
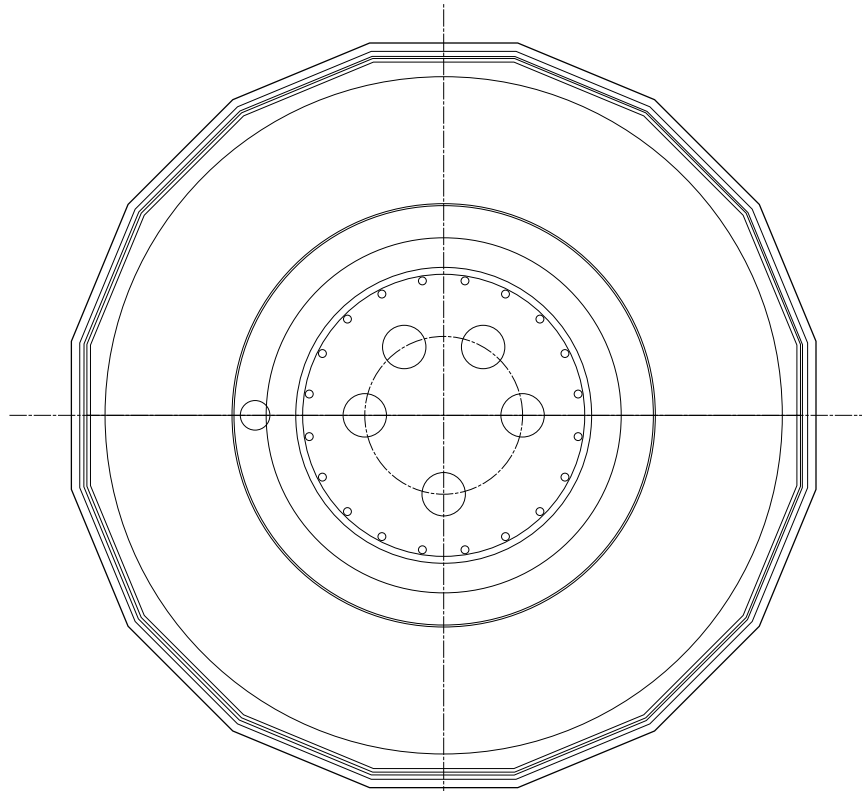
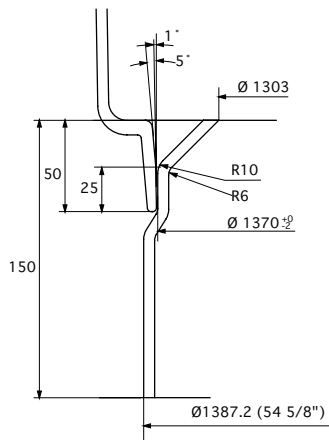

1.45m diameter sump with collar ring, corbel, internal lid, adjustable height skirt and round 900mm flat sealed cover and frame.

For reference purposes only. This drawing is not a specification. Order against product code only. To enable continuous improvement of our products, the designs and specifications are subject to change without notice.

FIBRELITE 
PART OF OPW A DOVER COMPANY

VERY IMPORTANT
OUTER EDGE "A" OF FRAME SET 5 - 10MM
ABOVE GENERAL FORECOURT AREA WITH
CONCRETE RAMPED AWAY OVER 300MM.

TYPICAL INSTALLATION

CONCRETE

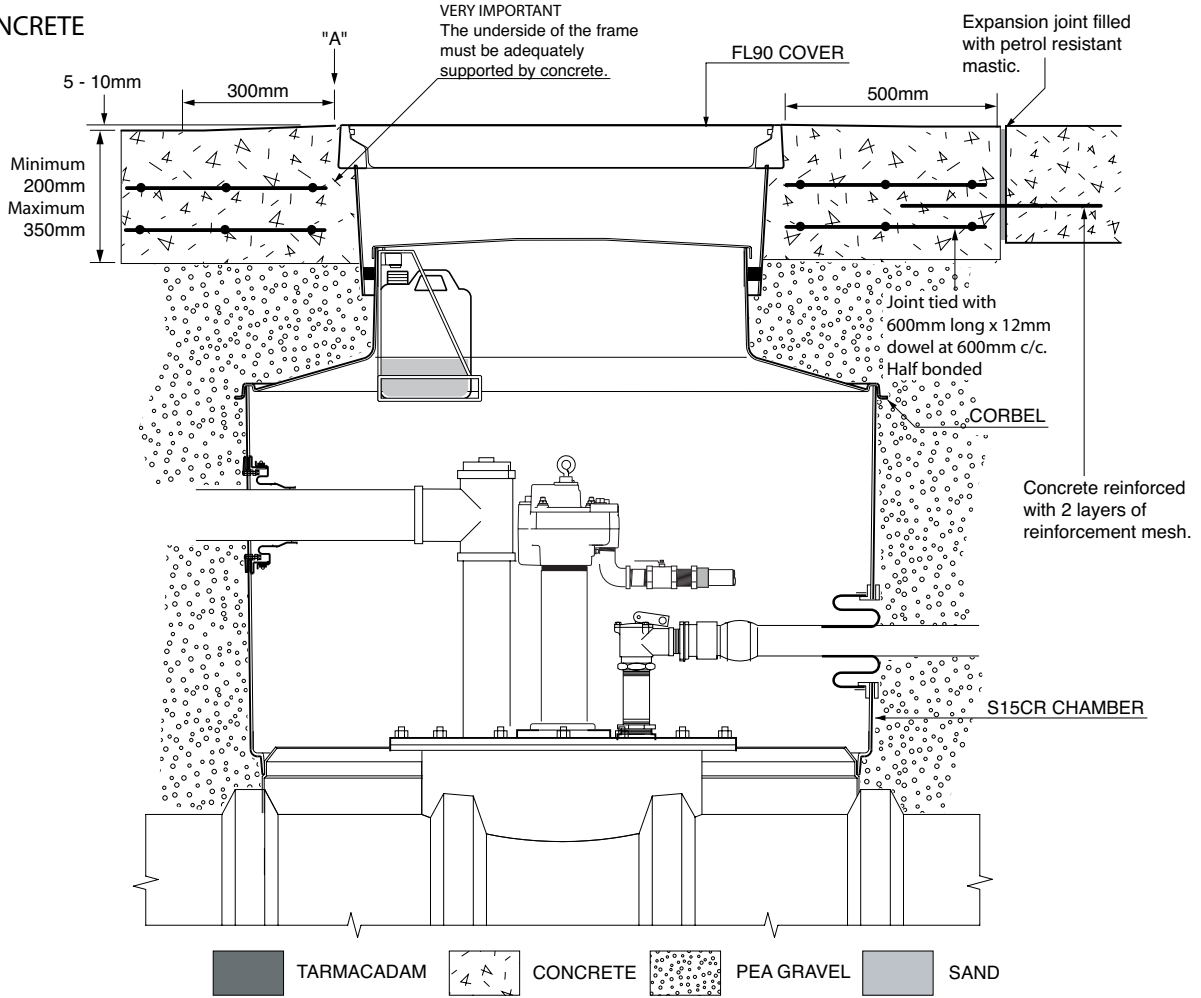

ALTERNATIVE INSTALLATION ADVICE

TARMACADAM

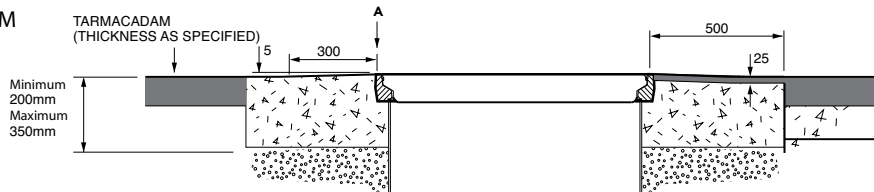

SETTS

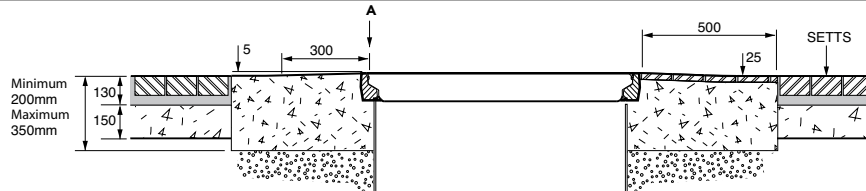

1.45m diameter sump with collar ring, corbel, internal lid, adjustable height skirt and round 900mm flat sealed cover and frame.

For reference purposes only. This drawing is not a specification. Order against product code only. To enable continuous improvement of our products, the designs and specifications are subject to change without notice.

FIBRELITE

PART OF OPW A DOVER COMPANY