

1.5m dia twelve sided sump with collar ring base. corbel, skirt, non structural internal lid with dipstick hole. 1020mm dia flat sealed cover with central sealed cover and frame.

For reference purposes only. This drawing is not a specification. Order against product code only. To enable continuous improvement of our products, the designs and specifications are subject to change without notice.

**FIBRELITE**   
PART OF OPW A DOVER COMPANY

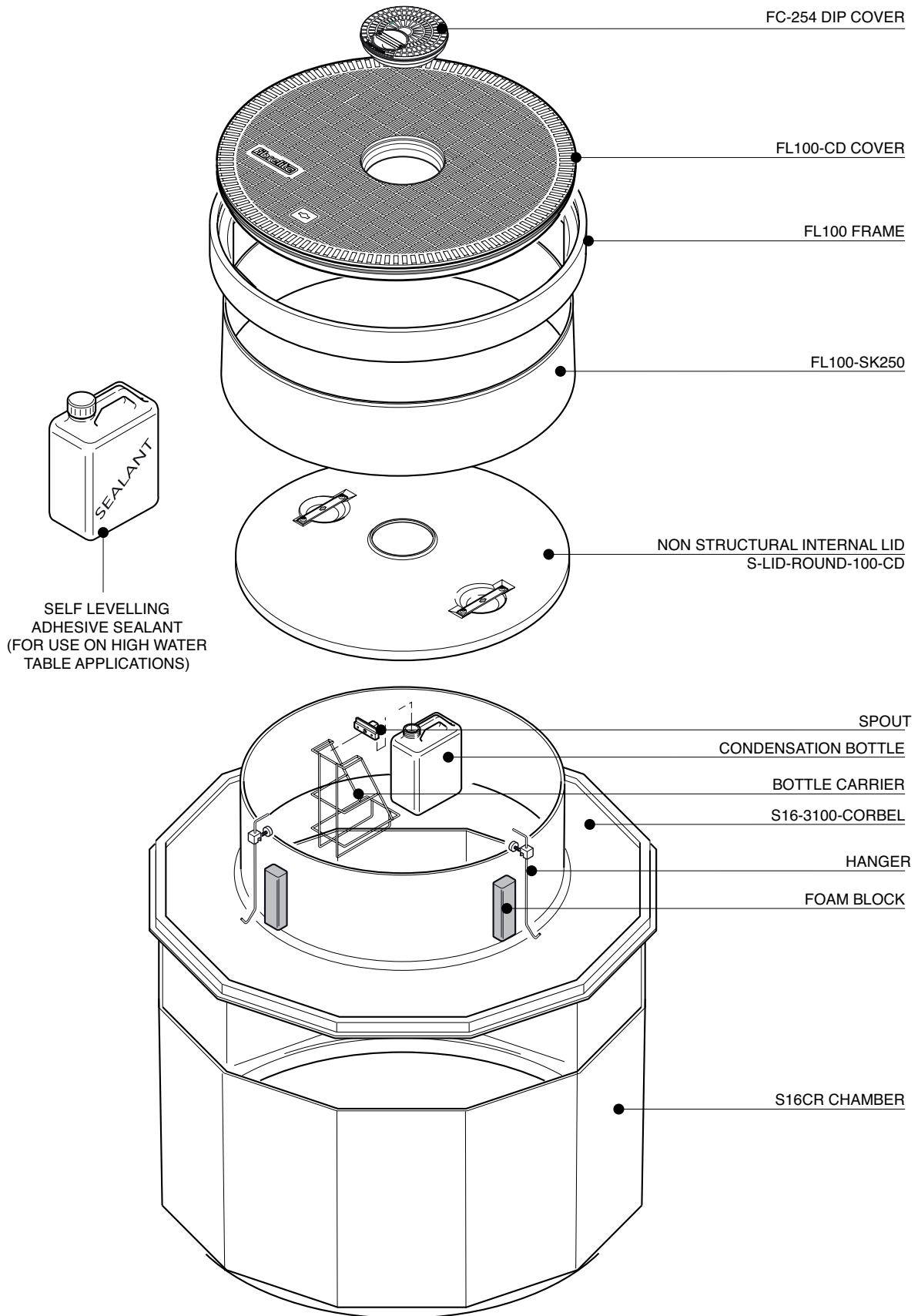

1.5m dia twelve sided sump with collar ring base. corbel, skirt, non structural internal lid with dipstick hole. 1020mm dia flat sealed cover with central sealed cover and frame.

For reference purposes only. This drawing is not a specification. Order against product code only. To enable continuous improvement of our products, the designs and specifications are subject to change without notice.



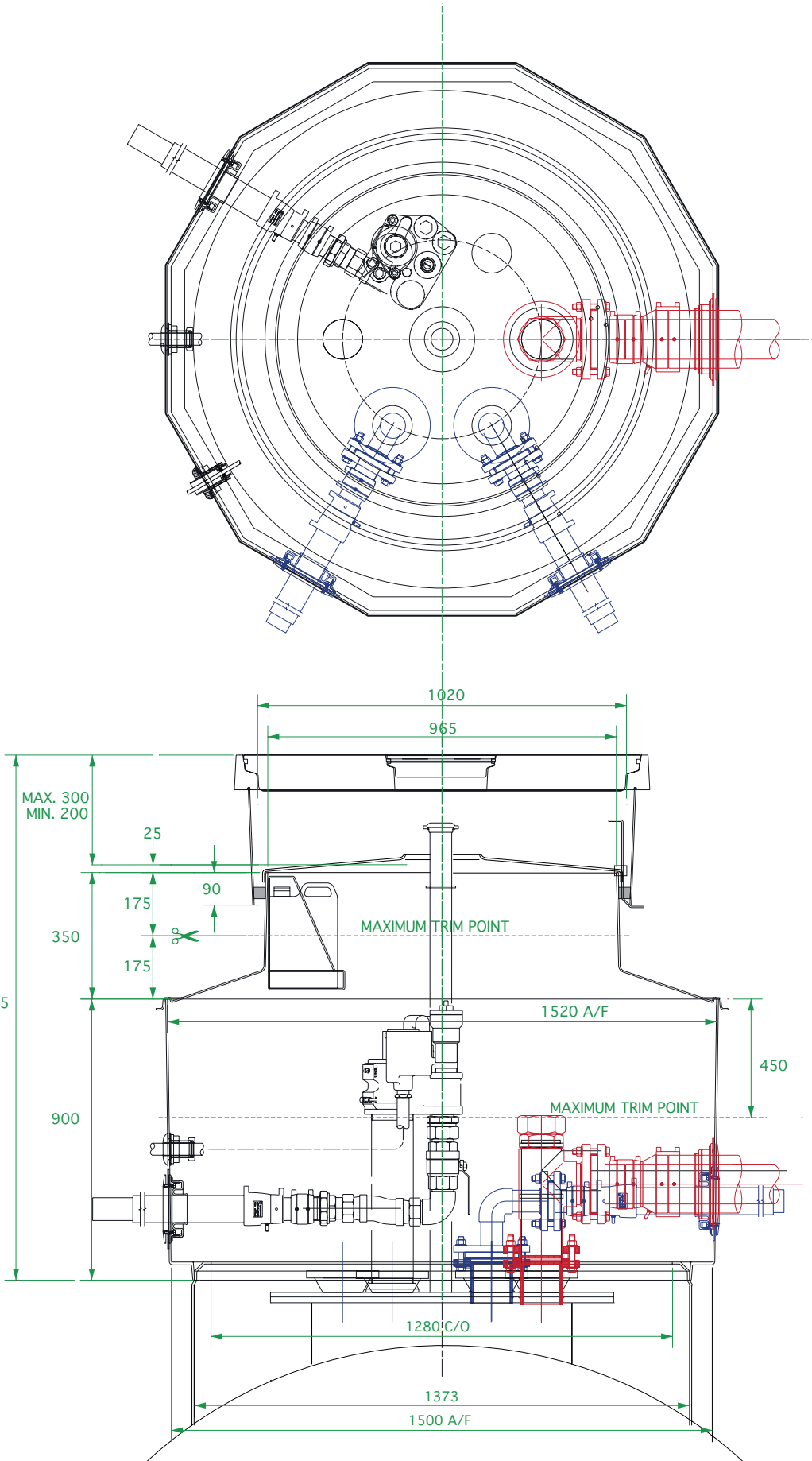

1.5m dia twelve sided sump with collar ring base, corbel, skirt, non structural internal lid with dipstick hole. 1020mm dia flat sealed cover with central sealed cover and frame.

For reference purposes only. This drawing is not a specification. Order against product code only. To enable continuous improvement of our products, the designs and specifications are subject to change without notice.

**FIBRELITE**   
PART OF OPW A DOWDER COMPANY

**VERY IMPORTANT**  
 OUTER EDGE "A" OF FRAME SET 5 - 10MM  
 ABOVE GENERAL FORECOURT AREA WITH  
 CONCRETE RAMPED AWAY OVER 300MM.

**TYPICAL INSTALLATION**

**CONCRETE**

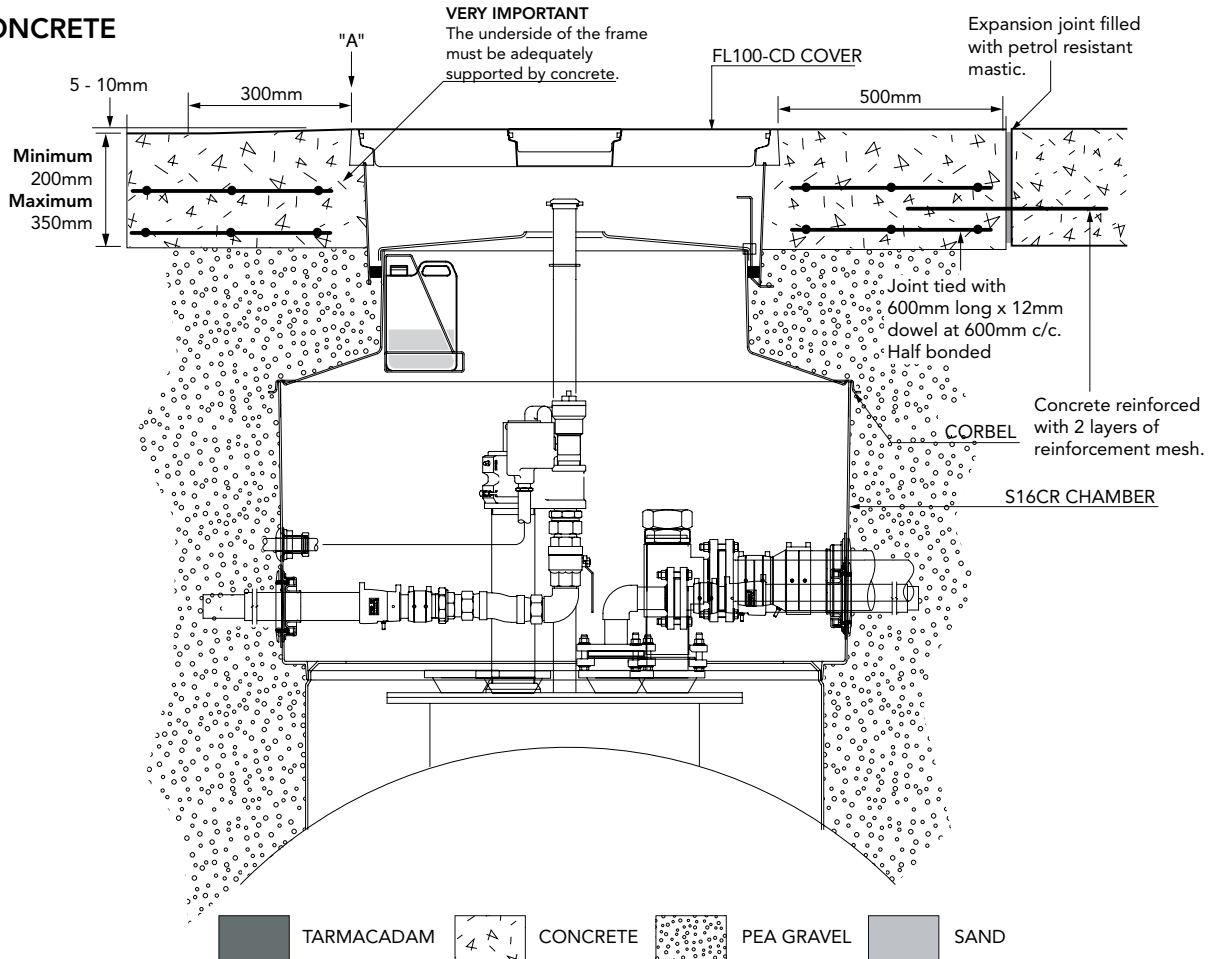

**ALTERNATIVE INSTALLATION ADVICE**

**TARMACADAM**

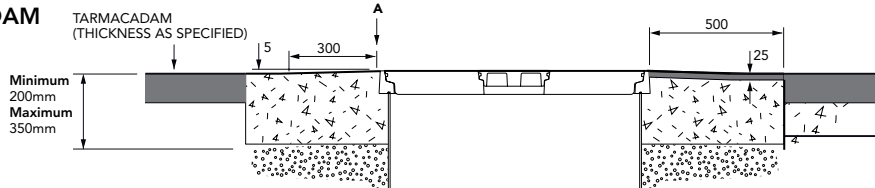

**SETTS**

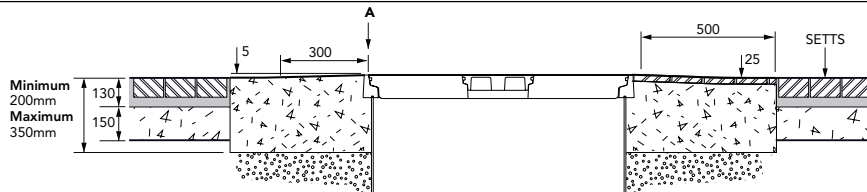

1.5m dia twelve sided sump with collar ring base. corbel, skirt, non structural internal lid with dipstick hole. 1020mm dia flat sealed cover with central sealed cover and frame.

For reference purposes only. This drawing is not a specification. Order against product code only. To enable continuous improvement of our products, the designs and specifications are subject to change without notice.

