

1.5m diameter 12 sided sump with collar ring base, corbel, adjustable height skirt, internal watertight platform, round 1020mm flat sealed cover and frame.

For reference purposes only. This drawing is not a specification. Order against product code only. To enable continuous improvement of our products, the designs and specifications are subject to change without notice.

FIBRELITE 
PART OF OPW A DOVER COMPANY

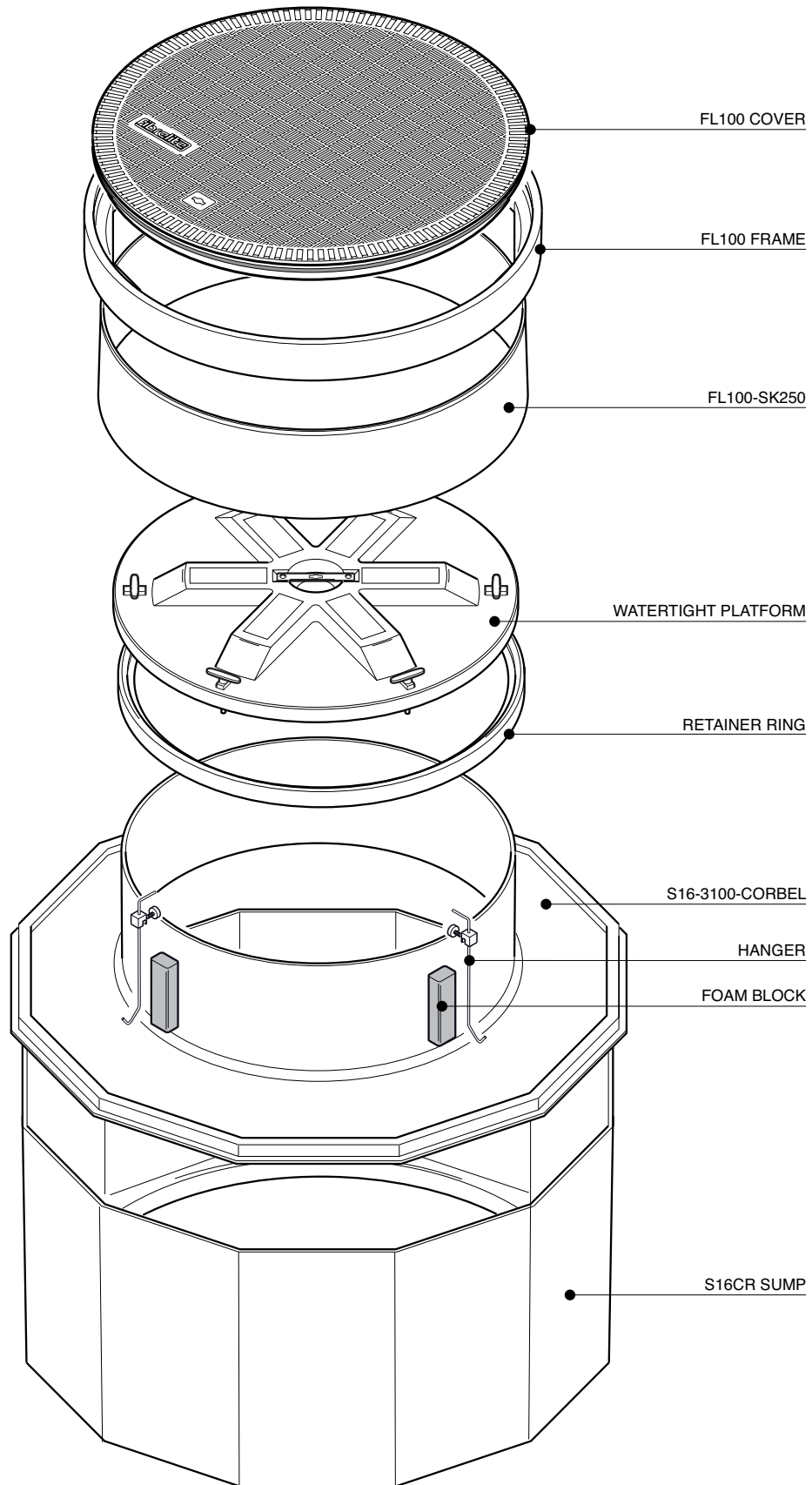

1.5m diameter 12 sided sump with collar ring base, corbel, adjustable height skirt, internal watertight platform, round 1020mm flat sealed cover and frame.

For reference purposes only. This drawing is not a specification. Order against product code only. To enable continuous improvement of our products, the designs and specifications are subject to change without notice.

FIBRELITE 
PART OF OPW A  COMPANY

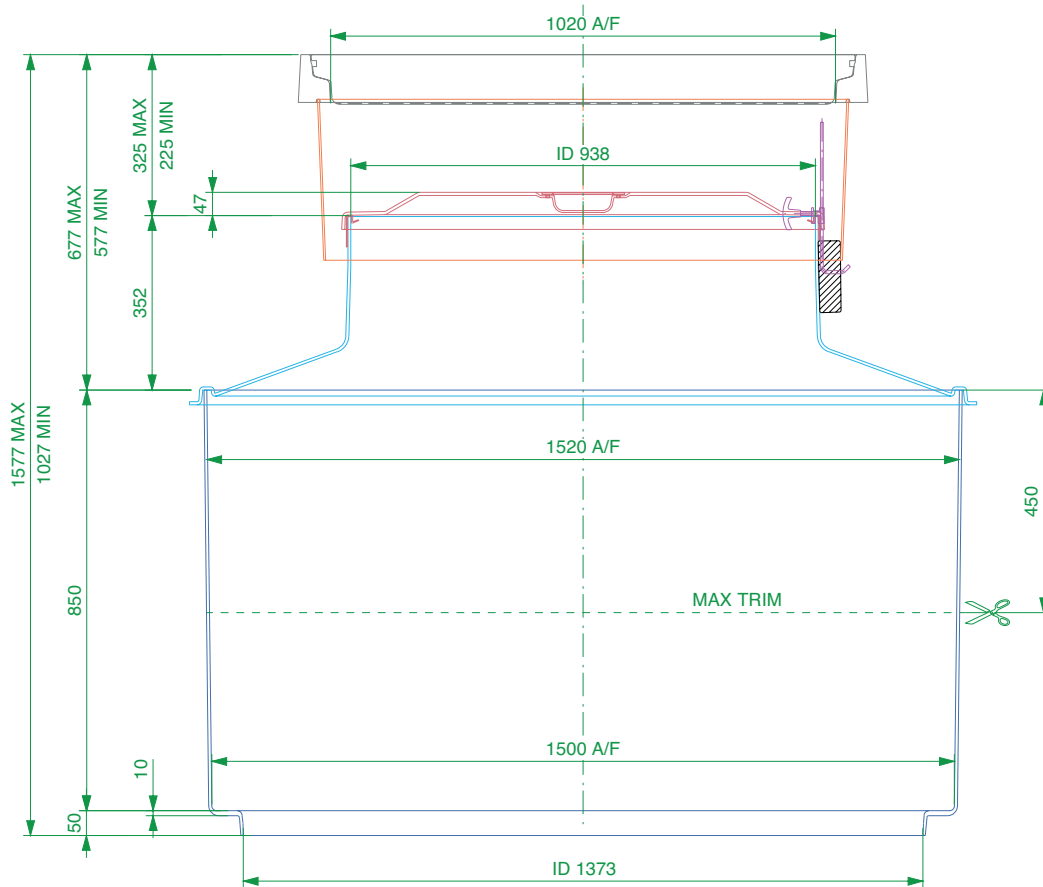
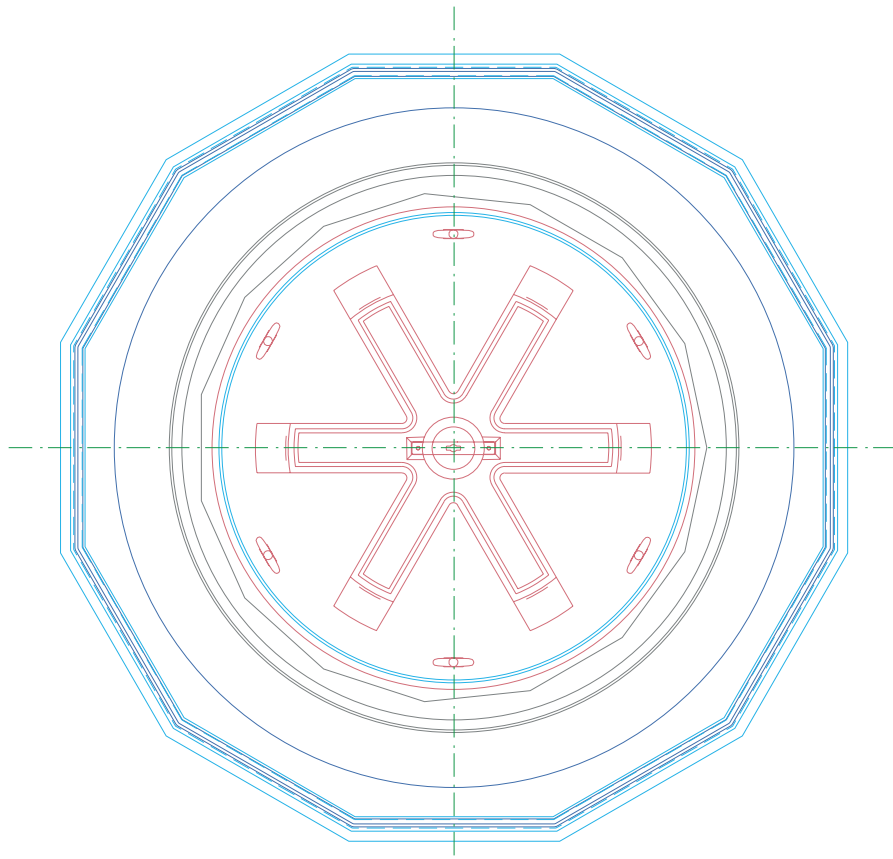

1.5m diameter 12 sided sump with collar ring base, corbel, adjustable height skirt, internal watertight platform, round 1020mm flat sealed cover and frame.

For reference purposes only. This drawing is not a specification. Order against product code only. To enable continuous improvement of our products, the designs and specifications are subject to change without notice.

FIBRELITE 
PART OF OPW A DOVER COMPANY

VERY IMPORTANT
 OUTER EDGE "A" OF FRAME SET 5 - 10MM
 ABOVE GENERAL FORECOURT AREA WITH
 CONCRETE RAMPED AWAY OVER 300MM.

TYPICAL INSTALLATION

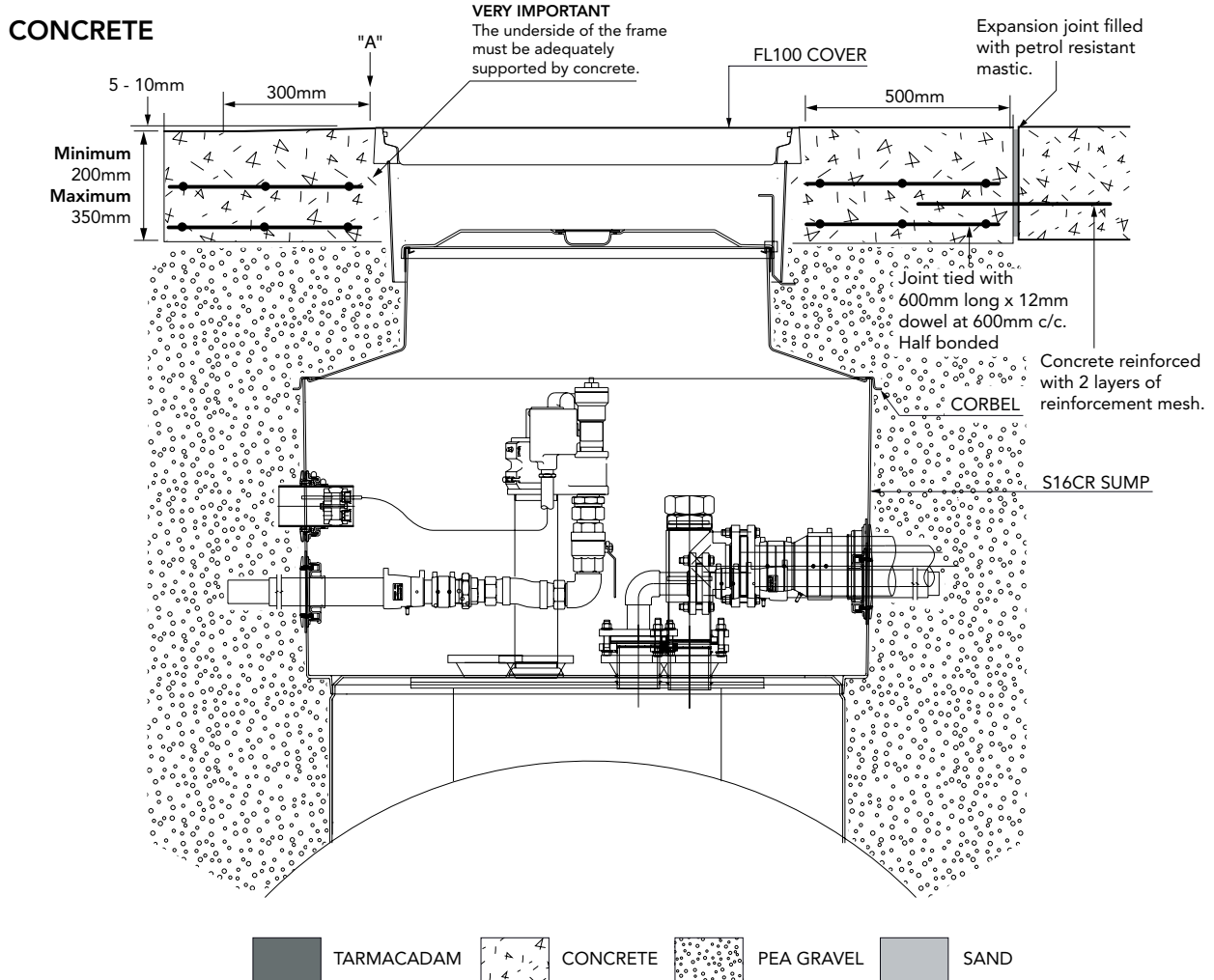

ALTERNATIVE INSTALLATION ADVICE

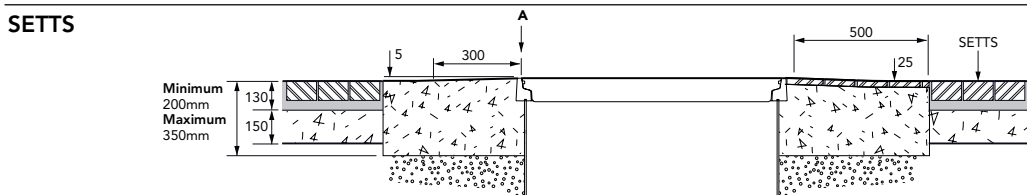
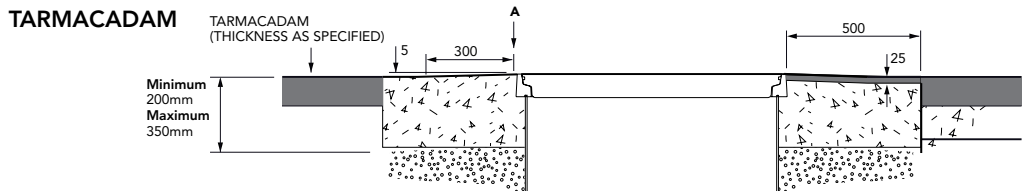

1.5m diameter 12 sided sump with collar ring base, corbel, adjustable height skirt, internal watertight platform, round 1020mm flat sealed cover and frame.

For reference purposes only. This drawing is not a specification. Order against product code only. To enable continuous improvement of our products, the designs and specifications are subject to change without notice.

FIBRELITE

PART OF OPW A DOWER COMPANY