

1.5m diameter 12 sided sump with solid base and manway lid adaptor, corbel, adjustable height skirt, internal lid, and round 1020mm flat sealed cover with central dip cover and frame.

For reference purposes only. This drawing is not a specification. Order against product code only. To enable continuous improvement of our products, the designs and specifications are subject to change without notice.

FIBRELITE 
PART OF OPW A DOVER COMPANY

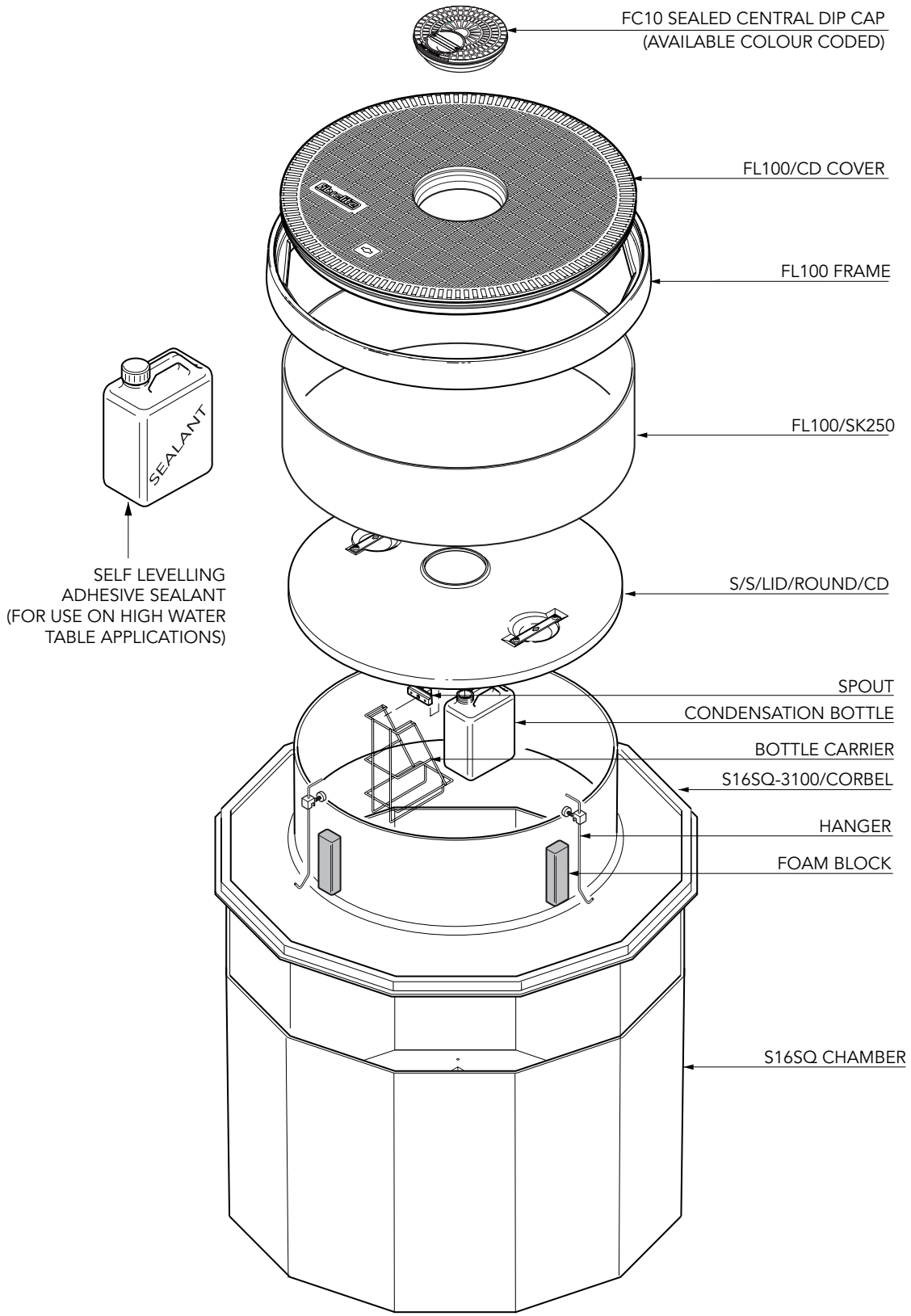

1.5m diameter 12 sided sump with solid base and manway lid adaptor, corbel, adjustable height skirt, internal lid, and round 1020mm flat sealed cover with central dip cover and frame.

For reference purposes only. This drawing is not a specification. Order against product code only. To enable continuous improvement of our products, the designs and specifications are subject to change without notice.



VERY IMPORTANT
 OUTER EDGE "A" OF FRAME SET 5 - 10MM
 ABOVE GENERAL FORECOURT AREA WITH
 CONCRETE RAMPED AWAY OVER 300MM.

TYPICAL INSTALLATION

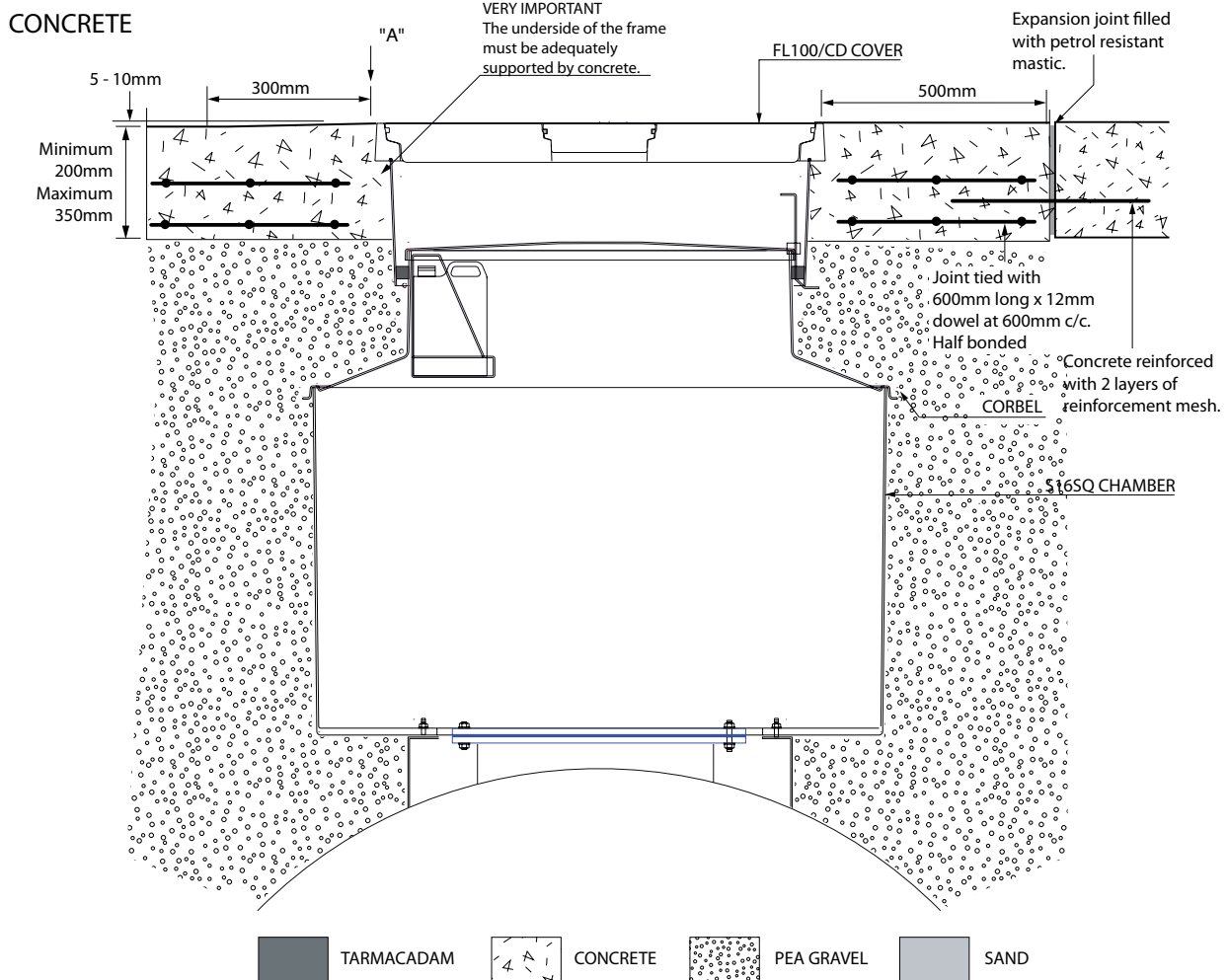

ALTERNATIVE INSTALLATION ADVICE

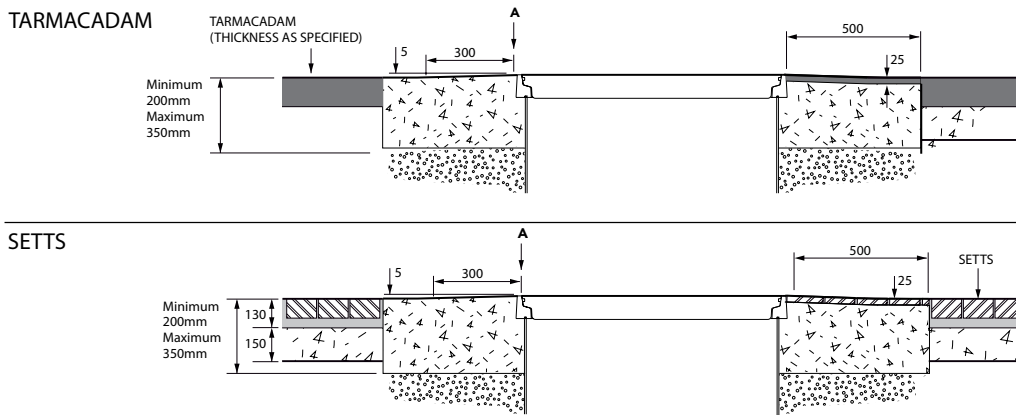

1.5m diameter 12 sided sump with solid base and manway lid adaptor, corbel, adjustable height skirt, internal lid, and round 1020mm flat sealed cover with central dip cover and frame.

For reference purposes only. This drawing is not a specification. Order against product code only. To enable continuous improvement of our products, the designs and specifications are subject to change without notice.

FIBRELITE

PART OF OPW A DOVER COMPANY

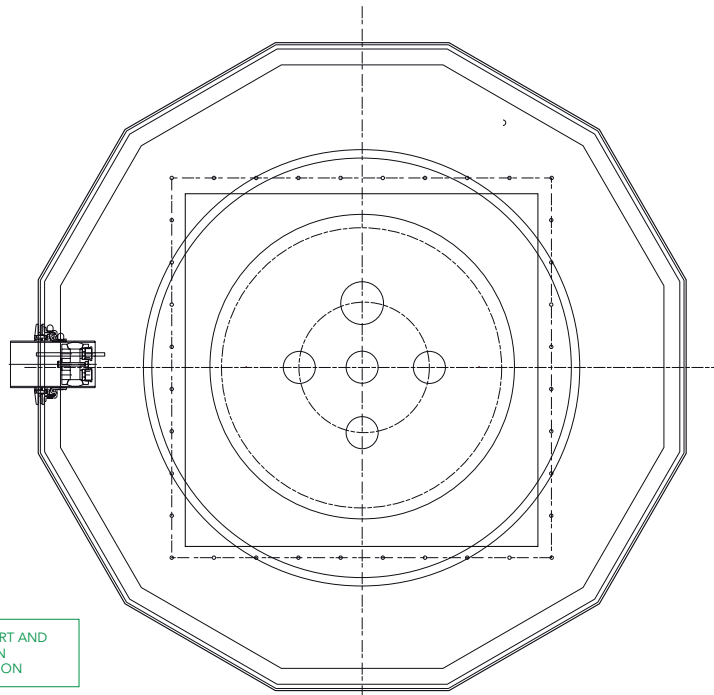

NOTE: SEALANT BETWEEN SKIRT AND CORBEL ONLY TO BE USED ON HIGH WATER TABLE APPLICATION

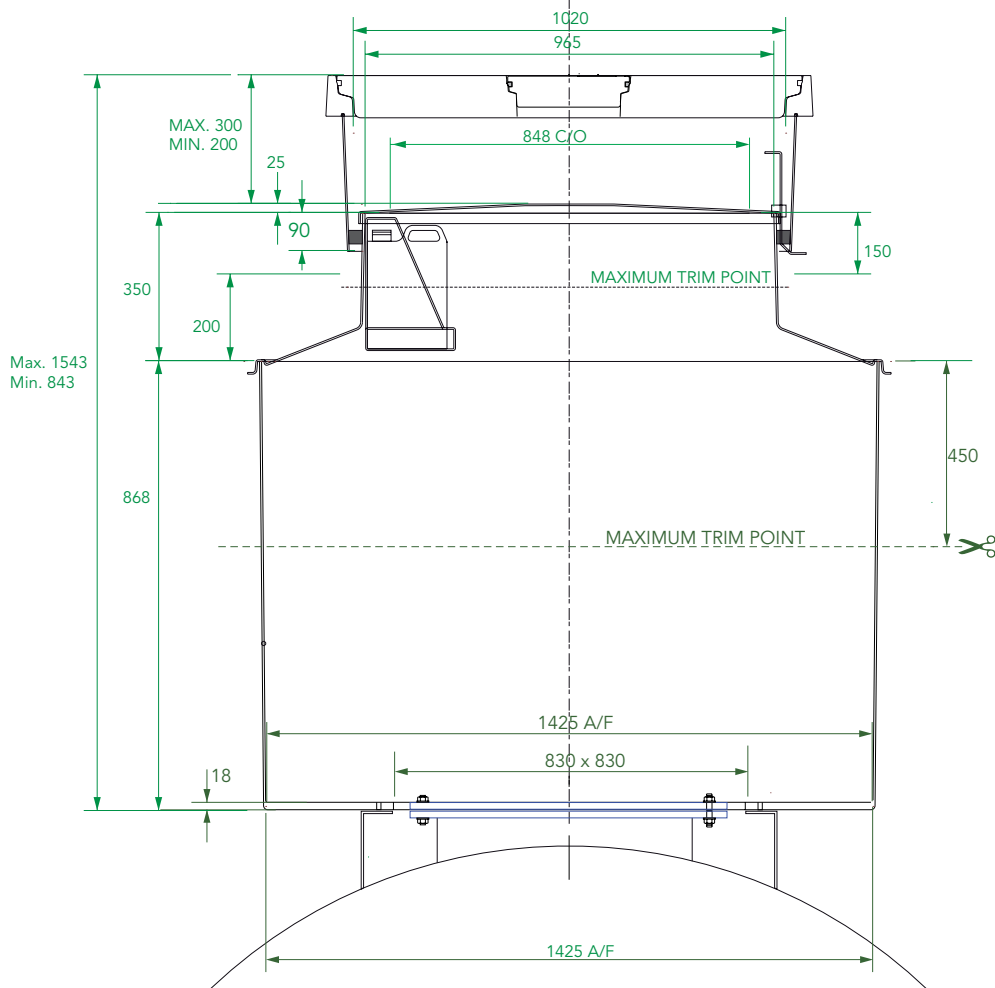

1.5m diameter 12 sided sump with solid base and manway lid adaptor, corbel, adjustable height skirt, internal lid, and round 1020mm flat sealed cover with central dip cover and frame.

For reference purposes only. This drawing is not a specification. Order against product code only. To enable continuous improvement of our products, the designs and specifications are subject to change without notice.

FIBRELITE 
PART OF OPW A DOWER COMPANY