

1.7m diameter stackable sump with collar ring base, stackable corbel, non-structural internal lid, adjustable height skirt, round 1020mm flat sealed cover and frame.

For reference purposes only. This drawing is not a specification. Order against product code only. To enable continuous improvement of our products, the designs and specifications are subject to change without notice.

**FIBRELITE**   
PART OF OPW A DOVER COMPANY

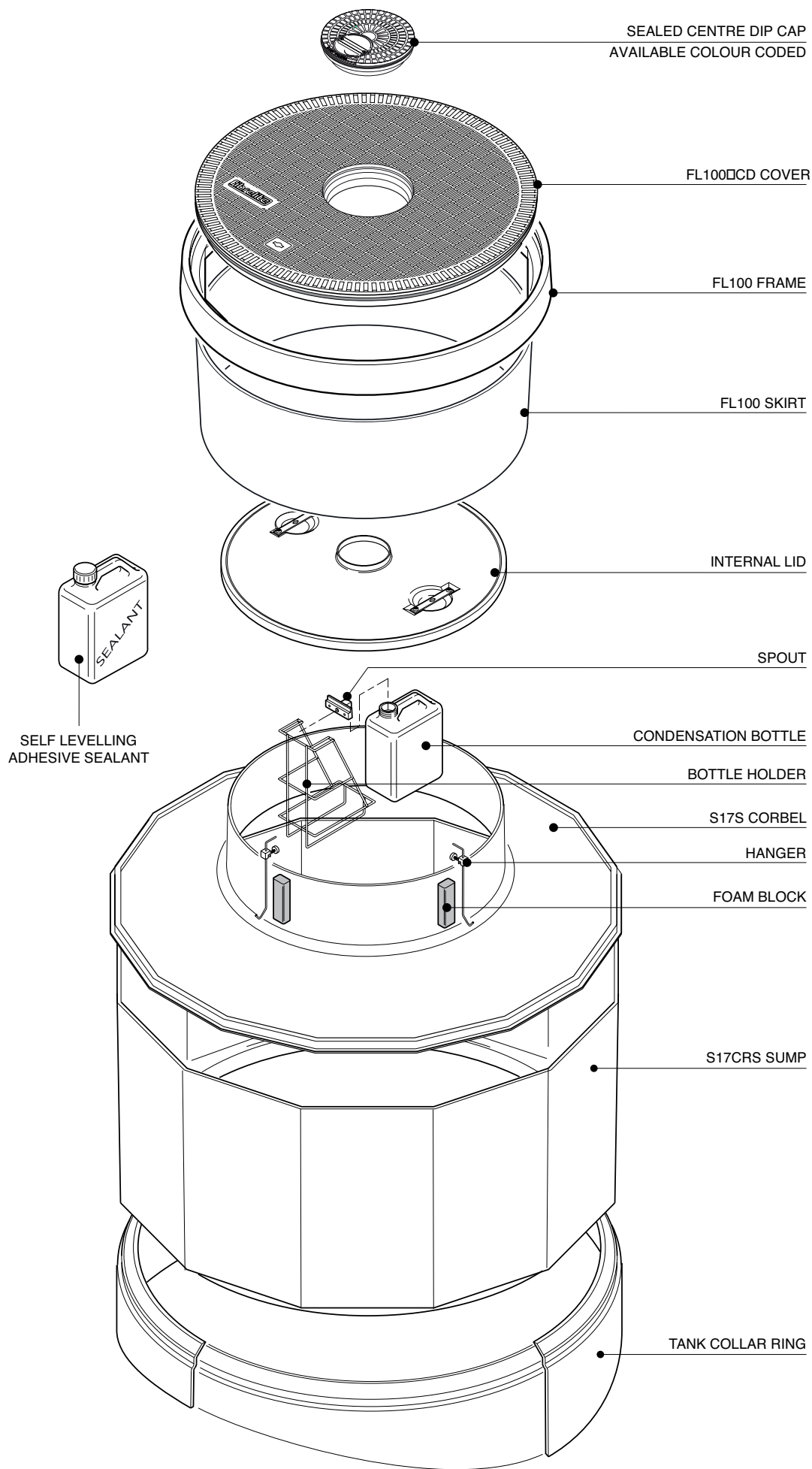

SEALED CENTRE DIP CAP  
AVAILABLE COLOUR CODED

FL100CD COVER

FL100 FRAME

FL100 SKIRT

INTERNAL LID

SPOUT

SELF LEVELLING  
ADHESIVE SEALANT

CONDENSATION BOTTLE

BOTTLE HOLDER

S17S CORBEL

HANGER

FOAM BLOCK

S17CRS SUMP

TANK COLLAR RING

1.7m diameter stackable sump with collar ring base, stackable corbel, non-structural internal lid, adjustable height skirt, round 1020mm flat sealed cover and frame.

For reference purposes only. This drawing is not a specification. Order against product code only. To enable continuous improvement of our products, the designs and specifications are subject to change without notice.

**FIBRELITE**   
PART OF OPW A DOWDER COMPANY

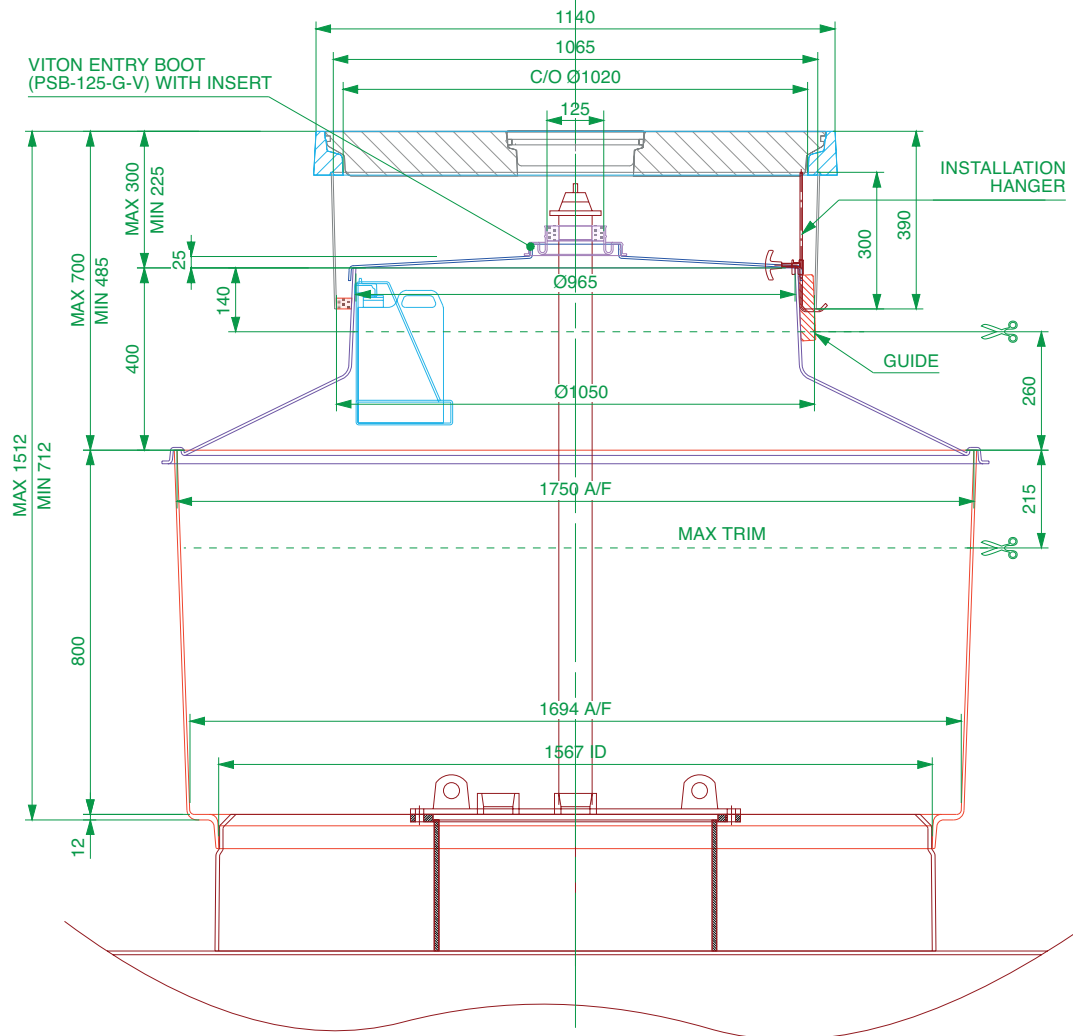
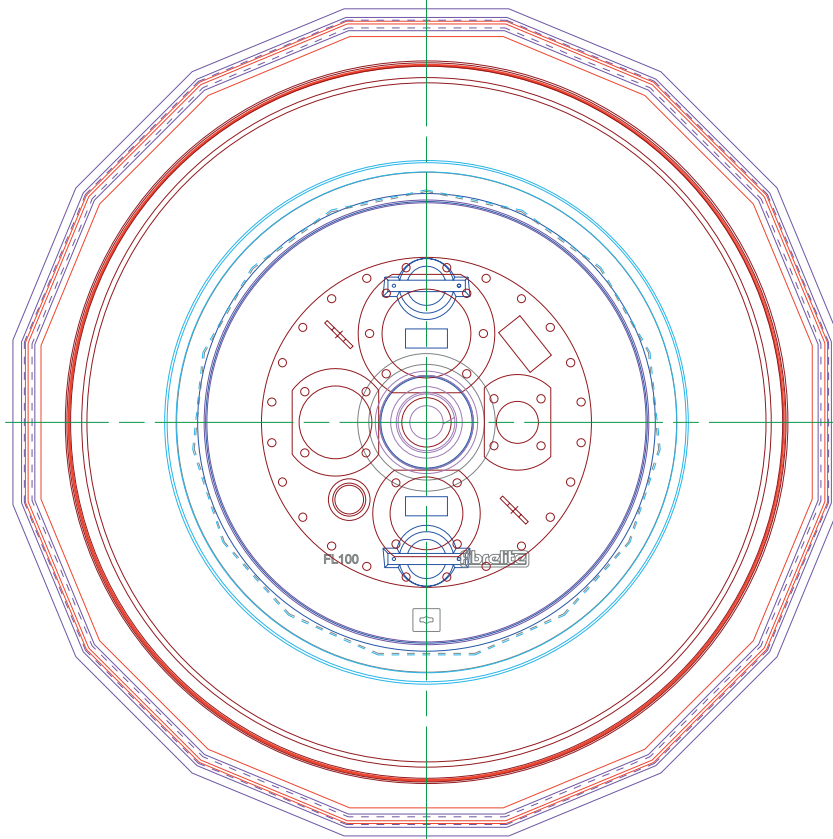

1.7m diameter stackable sump with collar ring base, stackable corbel, non-structural internal lid, adjustable height skirt, round 1020mm flat sealed cover and frame.

For reference purposes only. This drawing is not a specification. Order against product code only. To enable continuous improvement of our products, the designs and specifications are subject to change without notice.

**FIBRELITE**   
PART OF OPW A DOWDER COMPANY

