

500mm square x 600mm deep GRP solid base sump. GRP spill container with an integrated drainback system, GRP skirt, 760mm dia flat sealed cover and frame. ½ tin sealant. Designed to fit Environ pipework. 2 Fills.

For reference purposes only. This drawing is not a specification. Order against product code only. To enable continuous improvement of our products, the designs and specifications are subject to change without notice.

**FIBRELITE**   
PART OF OPW A DOVER COMPANY

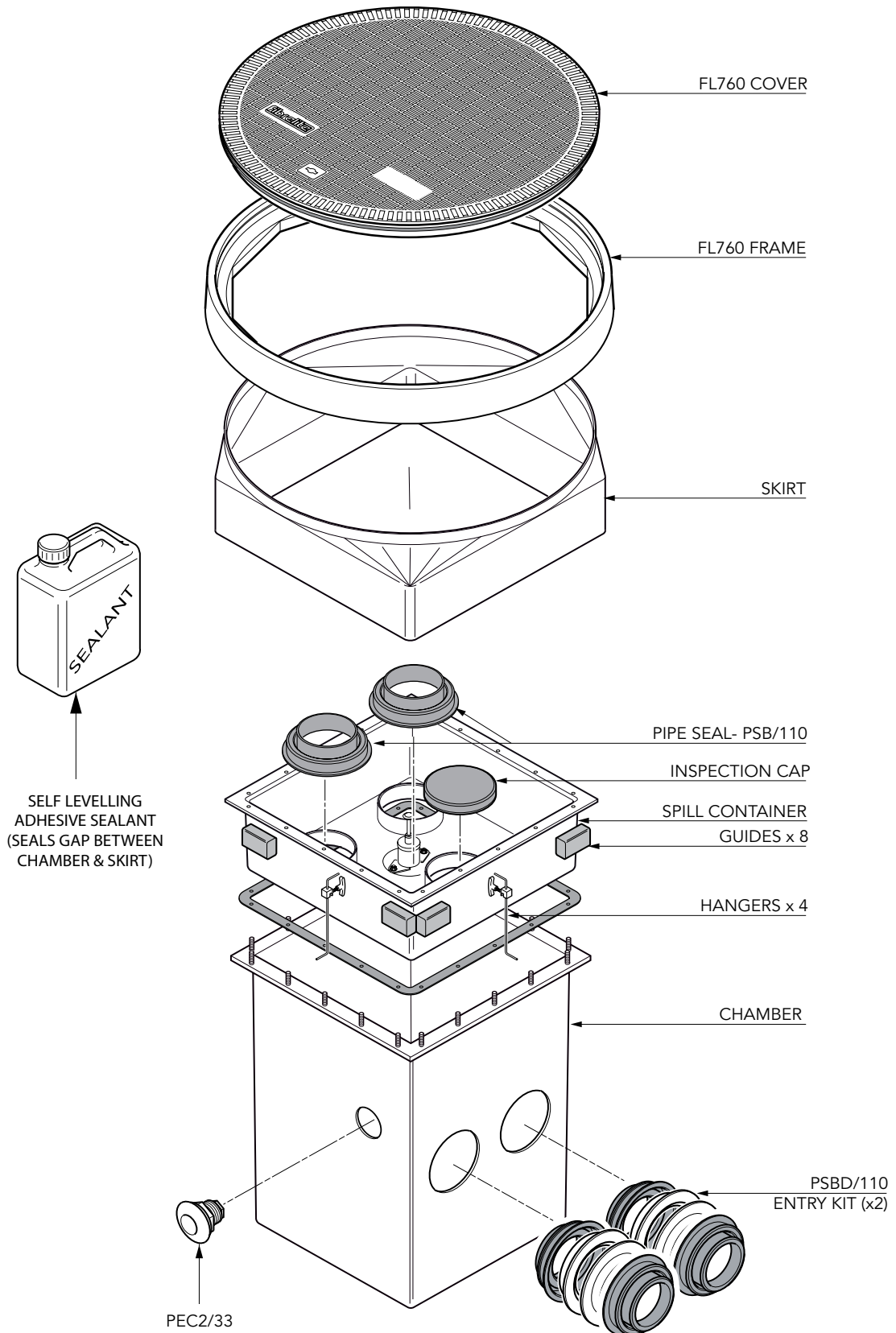

500mm square x 600mm deep GRP solid base sump. GRP spill container with an integrated drainback system, GRP skirt, 760mm dia flat sealed cover and frame. ½ tin sealant. Designed to fit Environ pipework. 2 Fills.

For reference purposes only. This drawing is not a specification. Order against product code only. To enable continuous improvement of our products, the designs and specifications are subject to change without notice.



Spill Containment  
Capacity =

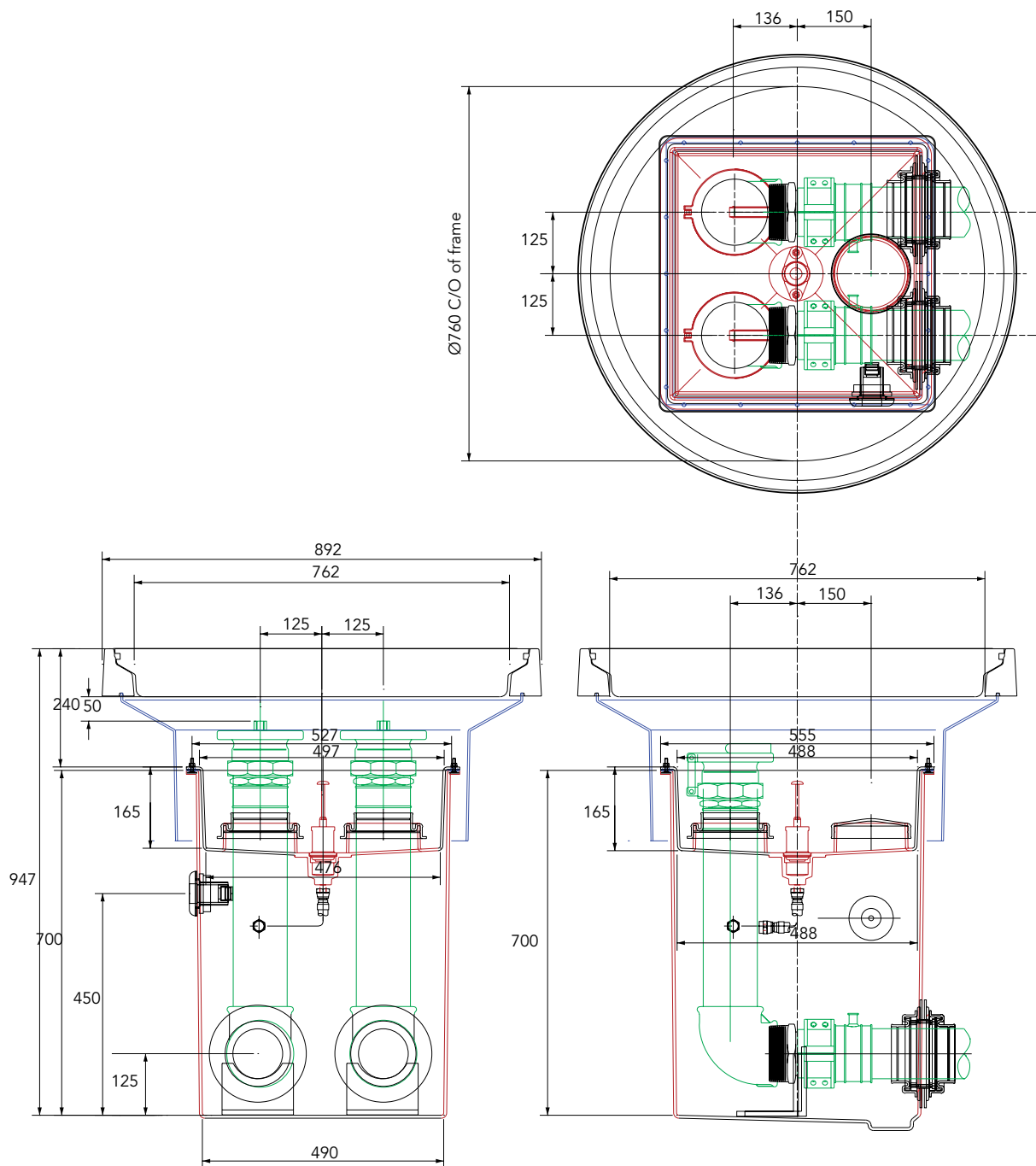

500mm square x 600mm deep GRP solid base sump. GRP spill container with an integrated drainback system, GRP skirt, 760mm dia flat sealed cover and frame. ½ tin sealant. Designed to fit Environ pipework. 2 Fills.

For reference purposes only. This drawing is not a specification. Order against product code only. To enable continuous improvement of our products, the designs and specifications are subject to change without notice.

**FIBRELITE**   
PART OF OPW A DOVER COMPANY

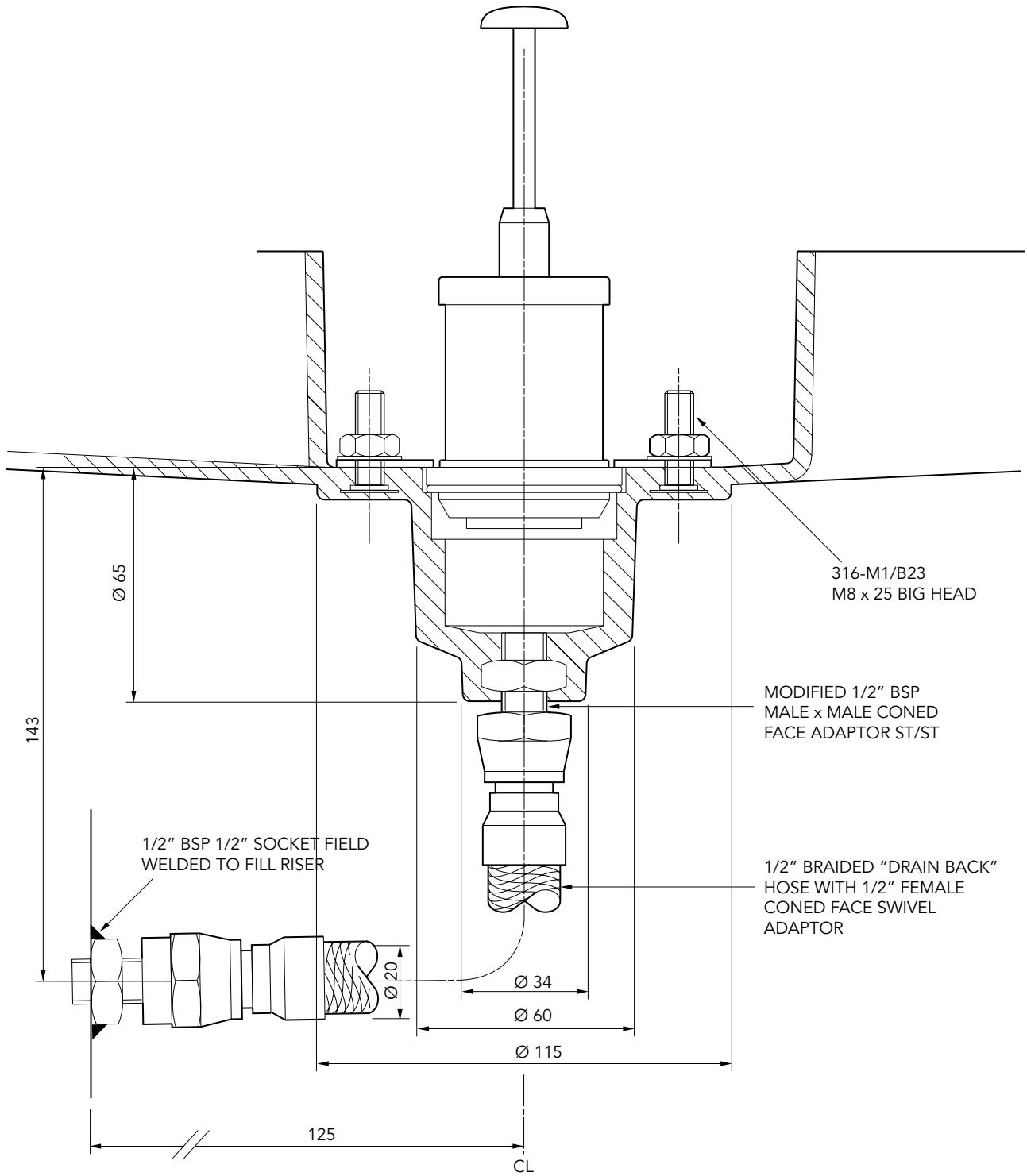

500mm square x 600mm deep GRP solid base sump. GRP spill container with an integrated drainback system, GRP skirt, 760mm dia flat sealed cover and frame. 1/2 tin sealant. Designed to fit Environ pipework. 2 Fills.

For reference purposes only. This drawing is not a specification. Order against product code only. To enable continuous improvement of our products, the designs and specifications are subject to change without notice.

**FIBRELITE**   
PART OF OPW A DOVER COMPANY

**TYPICAL INSTALLATION**

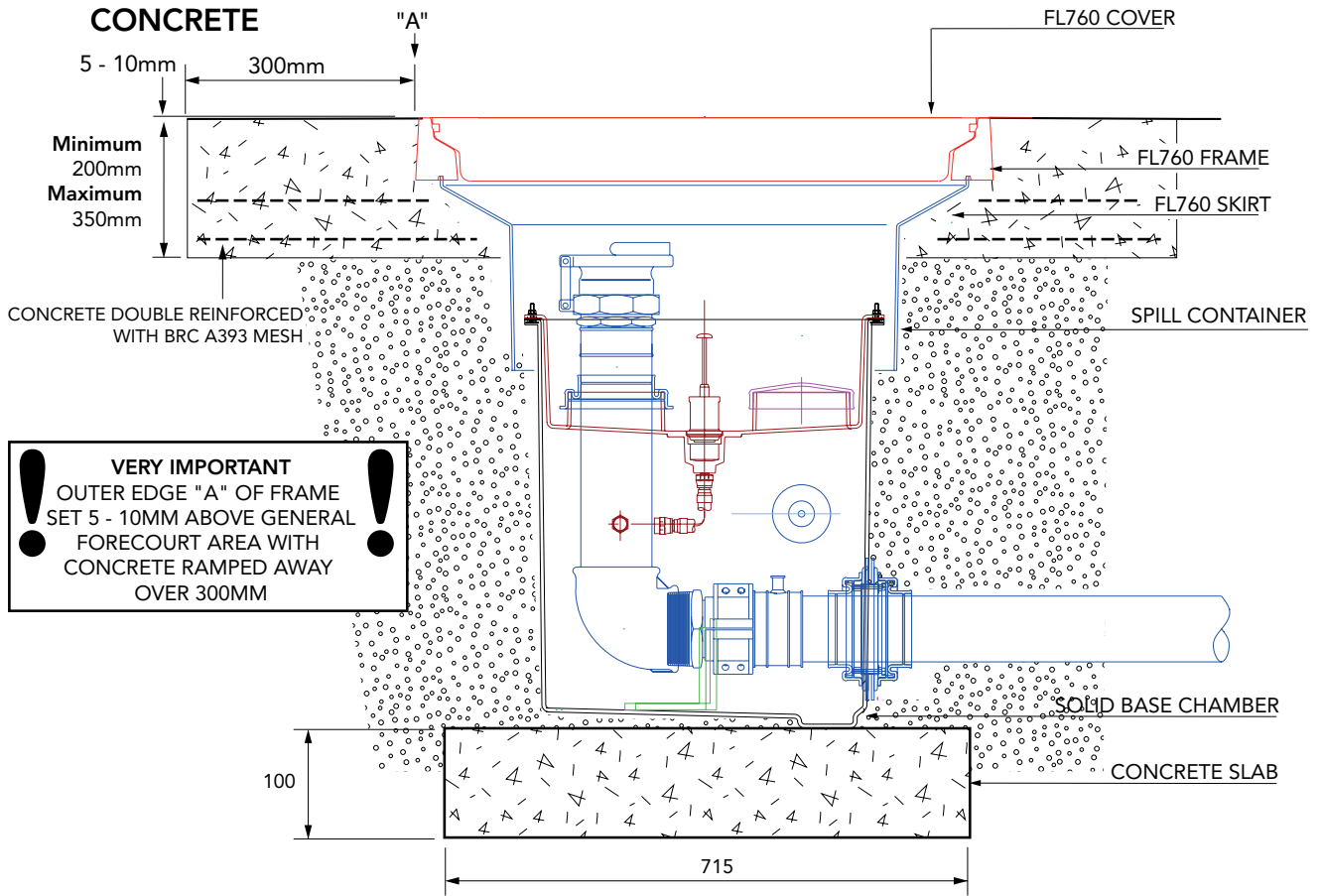

**ALTERNATIVE INSTALLATION ADVICE**

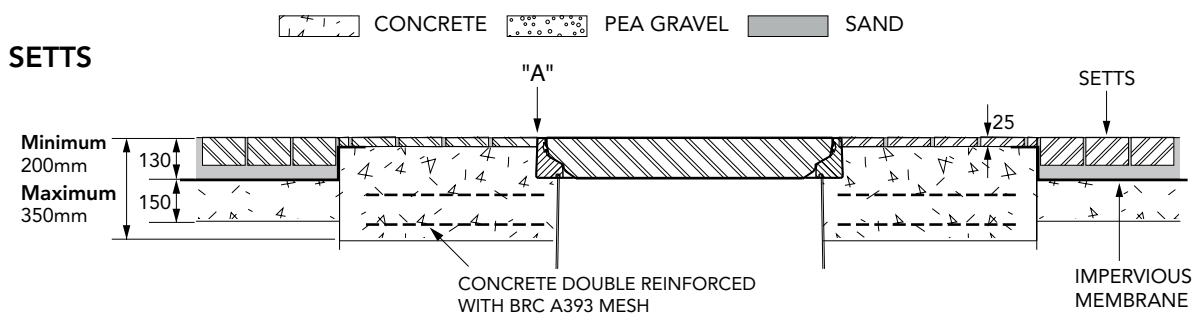

500mm square x 600mm deep GRP solid base sump, GRP spill container with an integrated drainback system, GRP skirt, 760mm dia flat sealed cover and frame. ½ tin sealant. Designed to fit Environ pipework. 2 Fills.

For reference purposes only. This drawing is not a specification. Order against product code only. To enable continuous improvement of our products, the designs and specifications are subject to change without notice.