

500mm square x 600mm deep GRP solid base sump. GRP spill container with an integrated drainback system, GRP skirt, 760mm dia flat sealed cover and frame. ½ tin sealant. Designed to fit UPP pipework. 2 Fills.

For reference purposes only. This drawing is not a specification. Order against product code only. To enable continuous improvement of our products, the designs and specifications are subject to change without notice.

FIBRELITE 
PART OF OPW A DOVER COMPANY

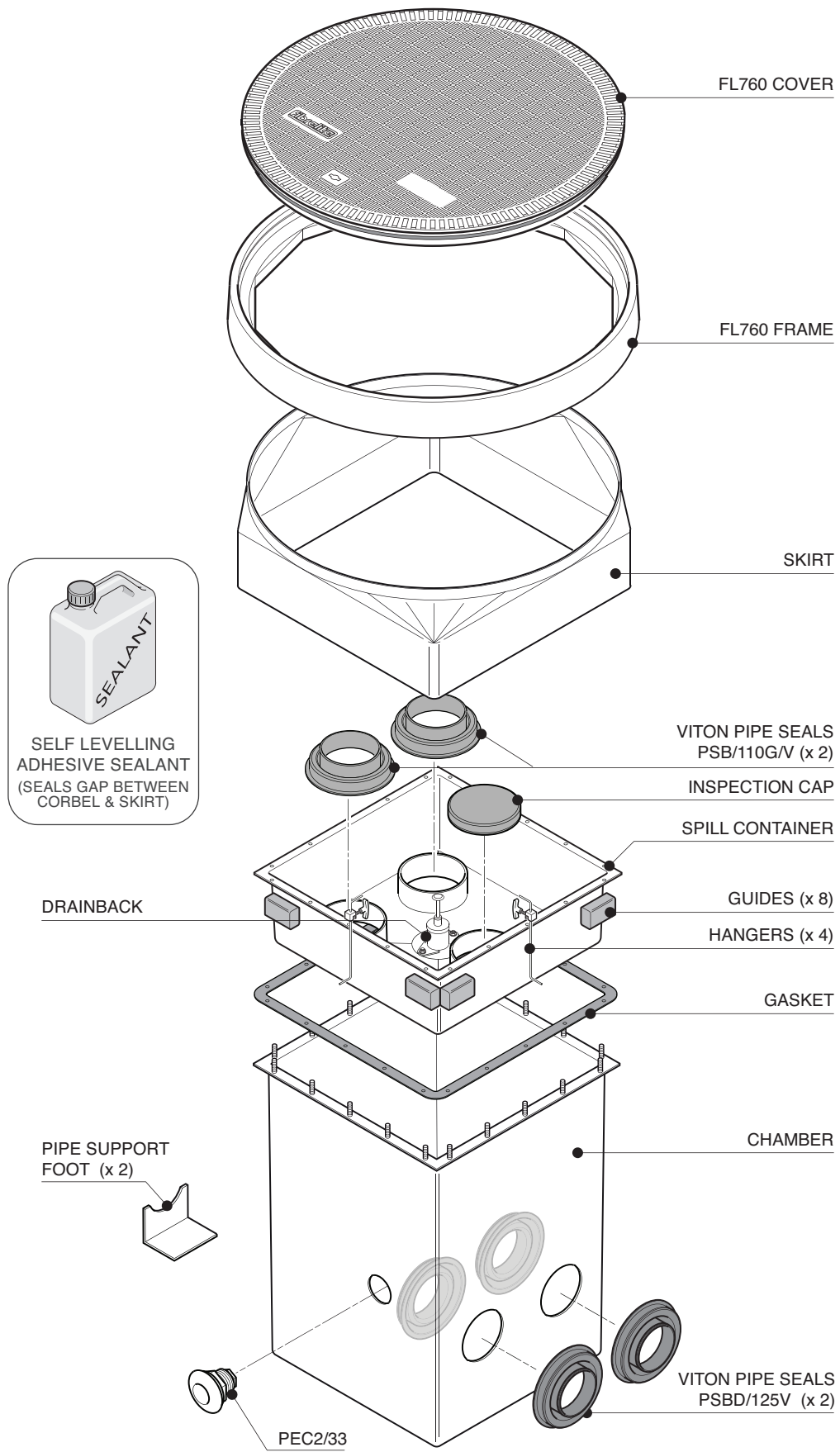

500mm square x 600mm deep GRP solid base sump. GRP spill container with an integrated drainback system, GRP skirt, 760mm dia flat sealed cover and frame. ½ tin sealant. Designed to fit UPP pipework. 2 Fills.

For reference purposes only. This drawing is not a specification. Order against product code only. To enable continuous improvement of our products, the designs and specifications are subject to change without notice.

FIBRELITE 
PART OF OPW A DOVER COMPANY

ITEM	DESCRIPTION	CODE	QTY
1	FibreLite FL760 Cover	FL760C	1
2	FibreLite FL760 Frame	FL760F	1
3	FibreLite 270mm Deep Skirt	FL760/SK300/OF	1
4	FibreLite Spill Container with Integrated Drain Back Valve	S2/SC/760/ROW	1
5	FibreLite 500sq x 770mm Sump	S2-OFB-760D	1
6	FibreLite Grounding Cable Seal	PEC/2/33	1
7	FibreLite Pipe Support	PSF	2
8	FibreLite Self-levelling Seal	S/CS/SEALANT	1
9	Drainback Hose Kit (Flexible Drain Back Hose, 1/2" BSPT Male x Male Cone Faced Adaptor, 1/2" BSP 1/2 Socket)	--	1
10	Drain Back Valve	--	1
11	Inspection Cap	--	1

ITEM	DESCRIPTION - 4" FILL	CODE	QTY
12	FibreLite Viton Ø125mm Double Sided Pipe Entry Seal	PSBD/125/V	2
13	EN Pipe - 110 mm Primary	001-110-XXX-E	2
14	EN Pipe - 125mm Secondary	000-125-XXX-SC-E	2
15	110mm Primary 90° Elbow	03-110-L	2
16	Primary Welding Coupler UPP 110mm	02.110	2
17	Reducer, SC, Term 110/90 TP	49-125-110-TP	2
18	TERM UPP 110mm 4" BSPT FEMALE	92-110 BSPT	2
19	CAP.ANTI-STATIC,12	ESI-CAP-012	12
20	PSB/110G Viton Entry Boot	PSB/110G/V	2

NOTES:

- SUPPLIED WITH 4 No. HANGERS AND 8 No. FOAM GUIDES
- DRAIN BACK SEALING OFF KIT AVAILABLE FOR NON-DRAINBACK VERSIONS
- SPILL CONTAINMENT CAPACITY = 35 Litres / 9.25 US GALL

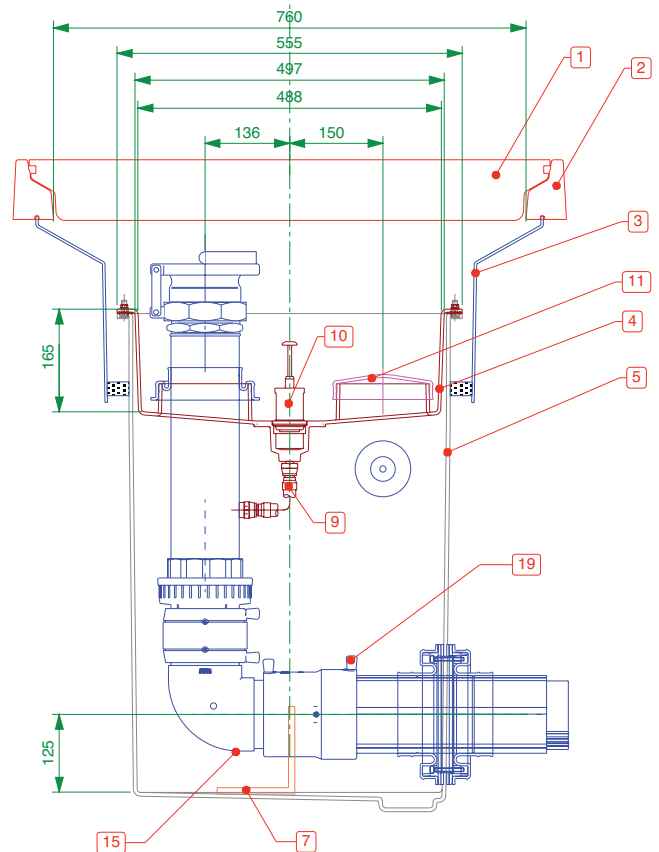
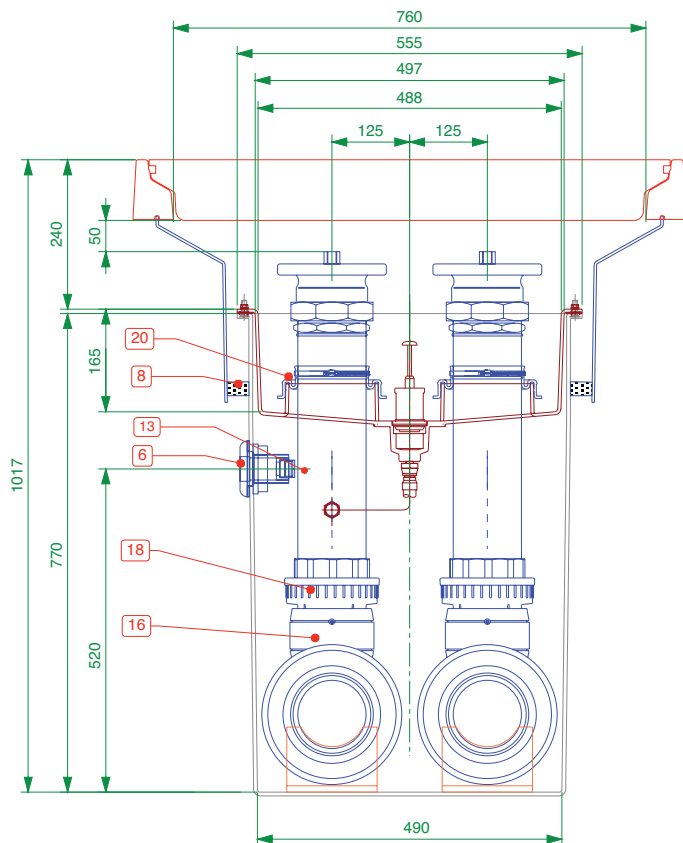
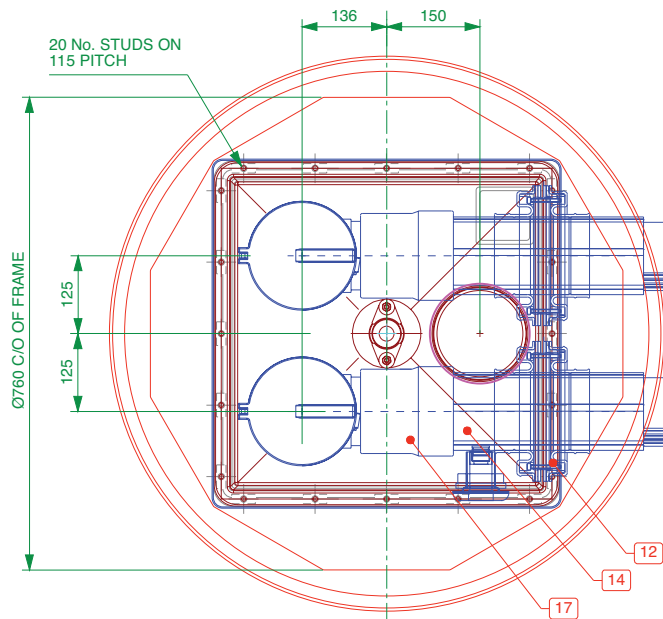

500mm square x 600mm deep GRP solid base sump, GRP spill container with an integrated drainback system, GRP skirt, 760mm dia flat sealed cover and frame. ½ tin sealant. Designed to fit UPP pipework. 2 Fills.

For reference purposes only. This drawing is not a specification. Order against product code only. To enable continuous improvement of our products, the designs and specifications are subject to change without notice.

FIBRELITE 
PART OF OPW A DOVER COMPANY

DRAINBACK DETAILS

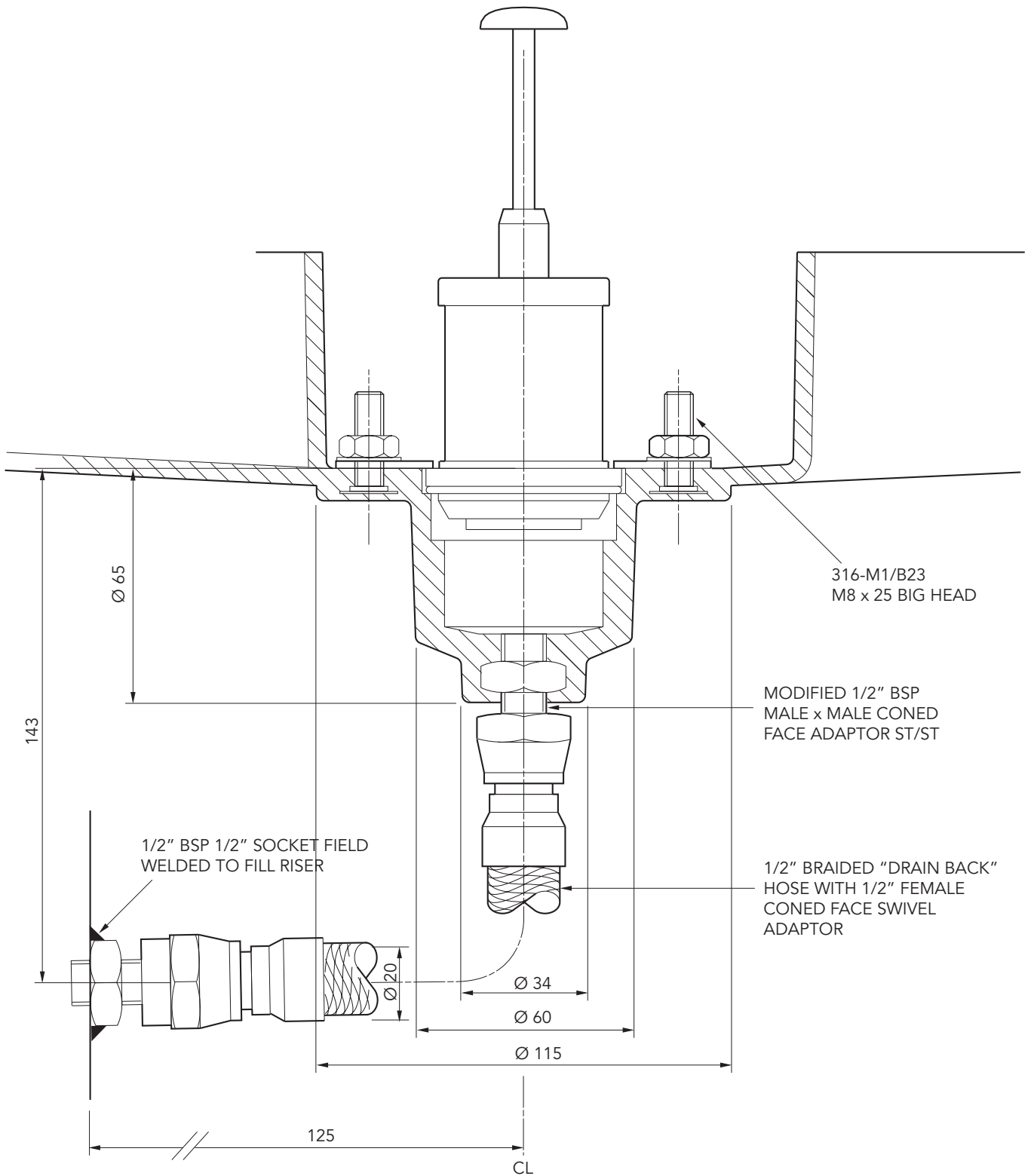

500mm square x 600mm deep GRP solid base sump, GRP spill container with an integrated drainback system, GRP skirt, 760mm dia flat sealed cover and frame. 1/2 tin sealant. Designed to fit UPP pipework. 2 Fills.

For reference purposes only. This drawing is not a specification. Order against product code only. To enable continuous improvement of our products, the designs and specifications are subject to change without notice.



TYPICAL INSTALLATION

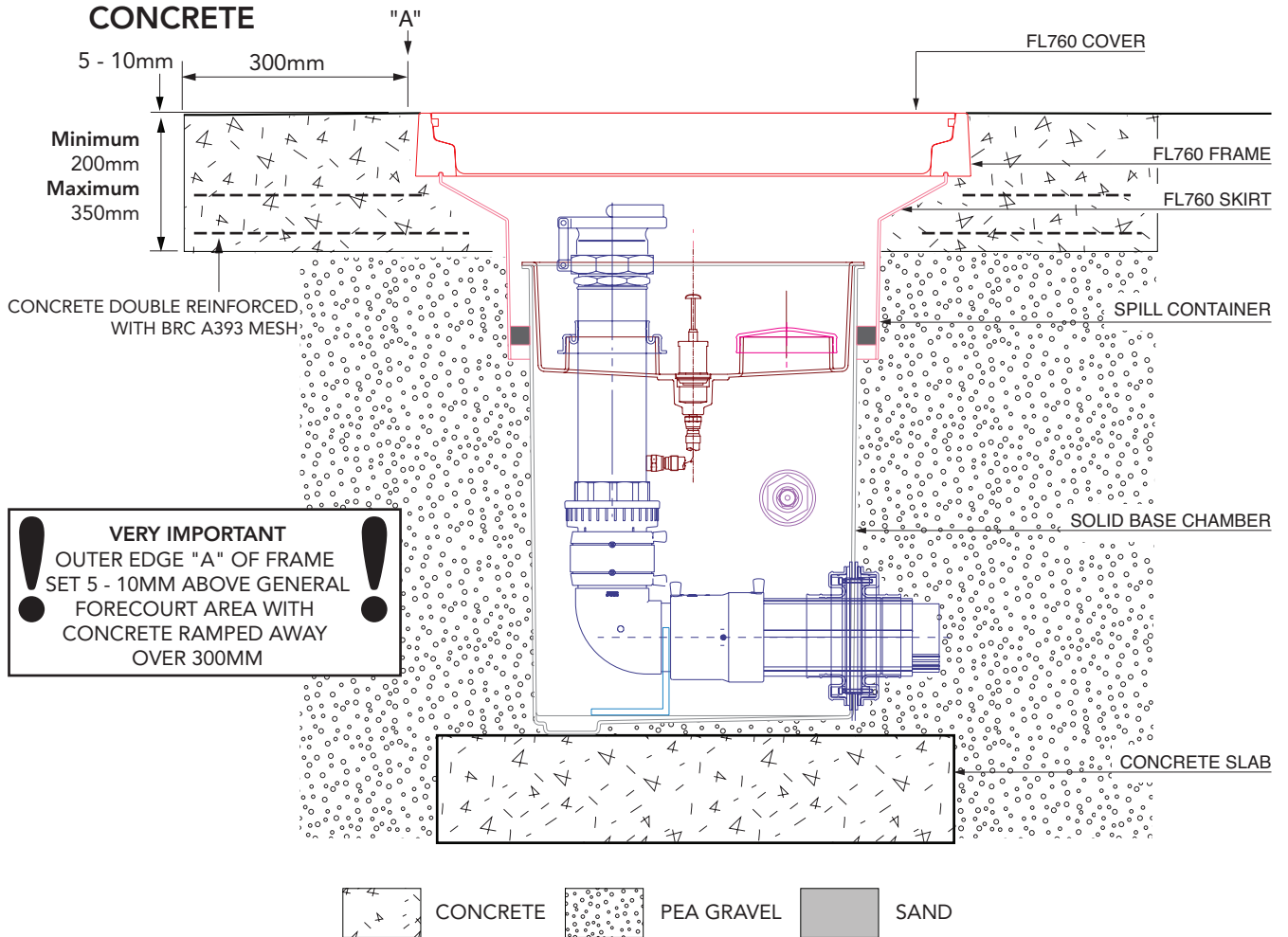

ALTERNATIVE INSTALLATION ADVICE

TARMACADAM

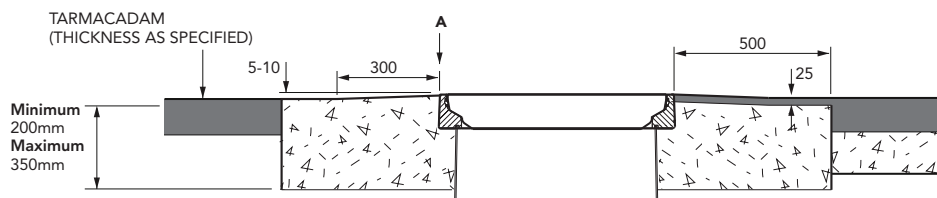

500mm square x 600mm deep GRP solid base sump, GRP spill container with an integrated drainback system, GRP skirt, 760mm dia flat sealed cover and frame. ½ tin sealant. Designed to fit UPP pipework. 2 Fills.

For reference purposes only. This drawing is not a specification. Order against product code only. To enable continuous improvement of our products, the designs and specifications are subject to change without notice.

FIBRELITE

PART OF OPW A DOVER COMPANY