

1.2m diameter bolted base chamber with a corbel, adjustable skirt, non-structural internal lid with a central port and round 900mm flat sealed cover with central manual dip cover. Round tank flange.

For reference purposes only. This drawing is not a specification. Order against product code only. To enable continuous improvement of our products, the designs and specifications are subject to change without notice.

FIBRELITE 
PART OF OPW A DOVER COMPANY

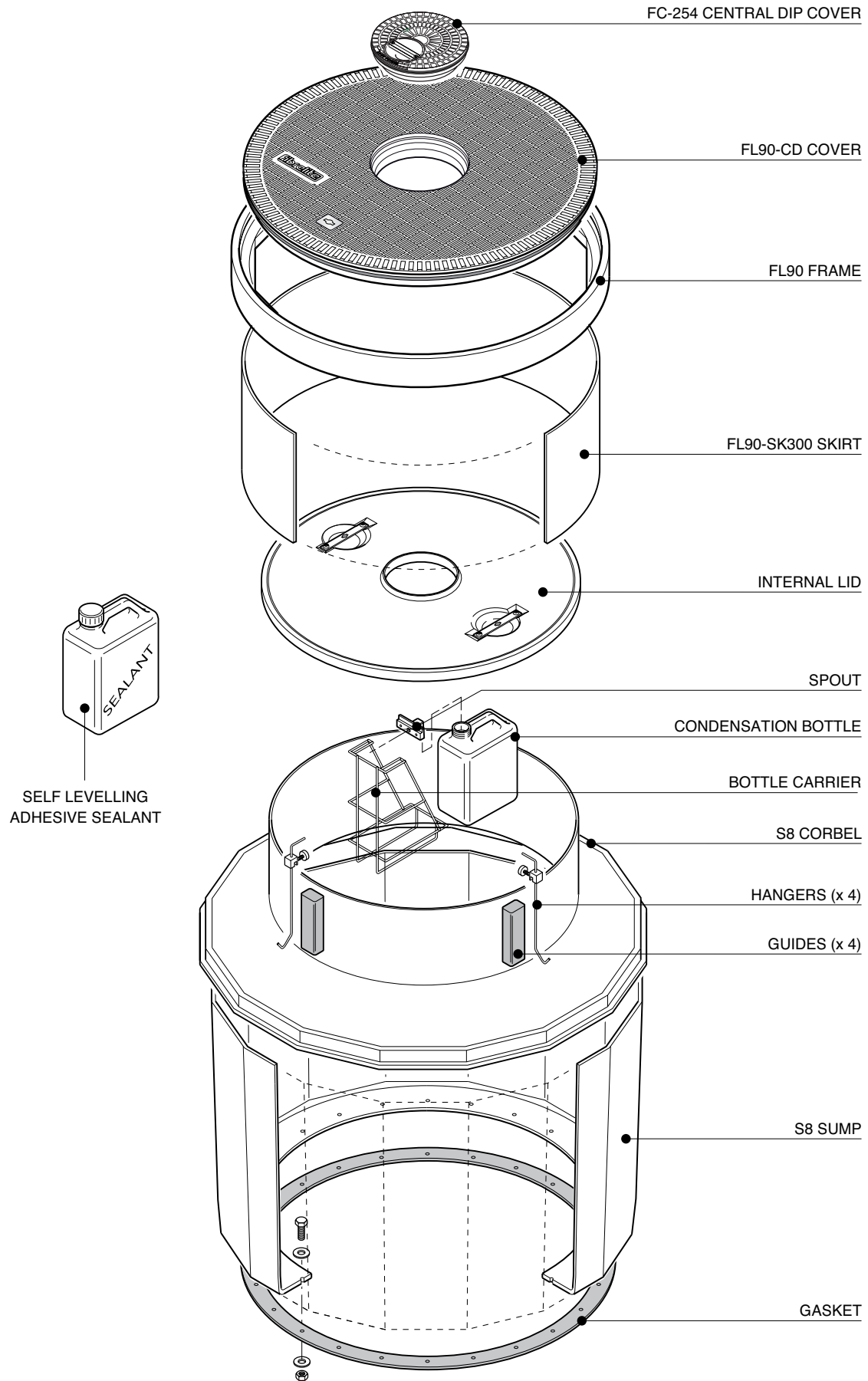

1.2m diameter bolted base chamber with a corbel, adjustable skirt, non-structural internal lid with a central port and round 900mm flat sealed cover with central manual dip cover. Round tank flange.

For reference purposes only. This drawing is not a specification. Order against product code only. To enable continuous improvement of our products, the designs and specifications are subject to change without notice.

FIBRELITE 
 PART OF OPW A DOWDER COMPANY

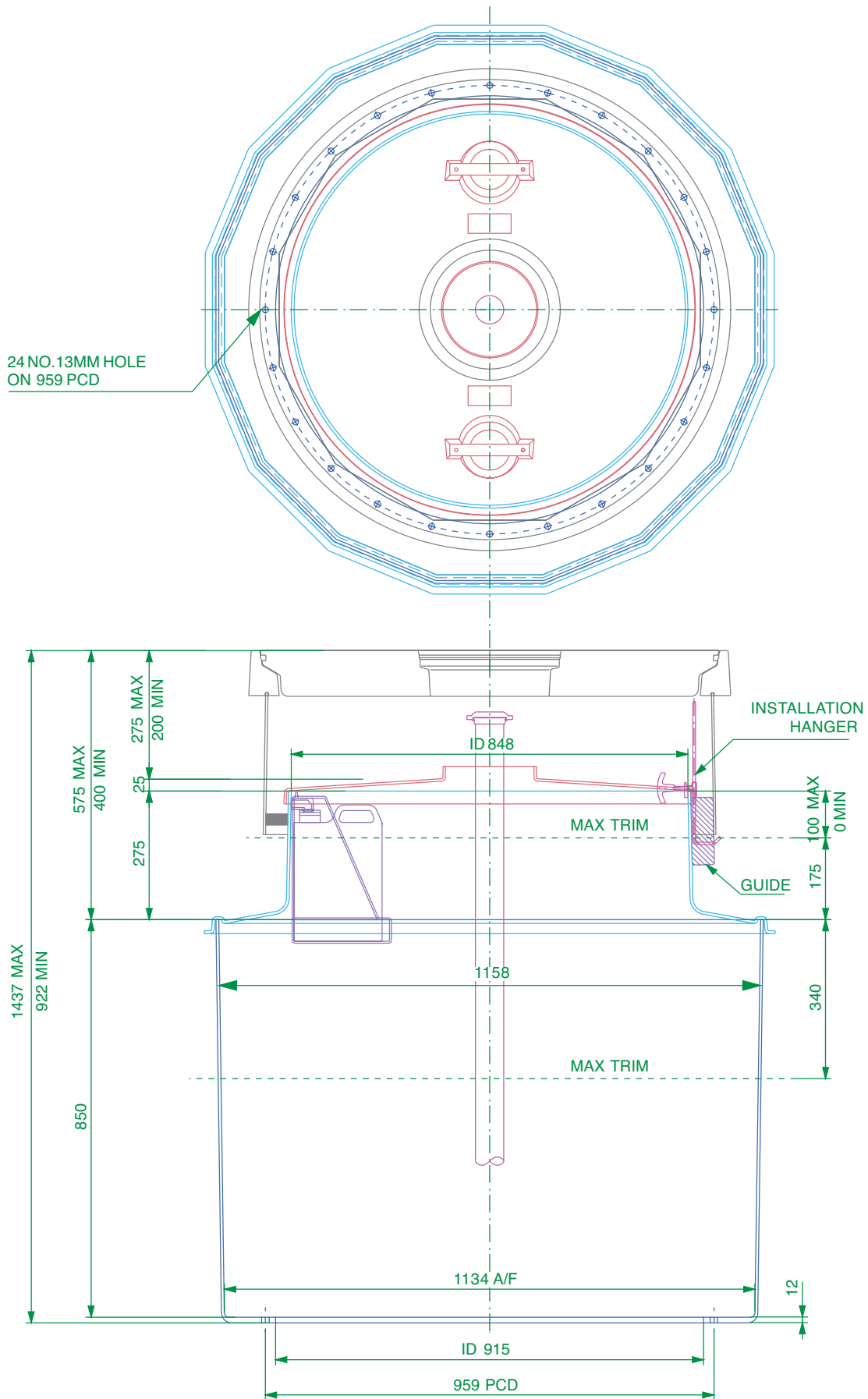

1.2m diameter bolted base chamber with a corbel, adjustable skirt, non-structural internal lid with a central port and round 900mm flat sealed cover with central manual dip cover. Round tank flange.

For reference purposes only. This drawing is not a specification. Order against product code only. To enable continuous improvement of our products, the designs and specifications are subject to change without notice.

FIBRELITE 
PART OF OPW A DOWDER COMPANY

VERY IMPORTANT
OUTER EDGE "A" OF FRAME SET 5-10MM
ABOVE GENERAL FORECOURT AREA WITH
CONCRETE RAMPED AWAY OVER 300MM.

TYPICAL INSTALLATION

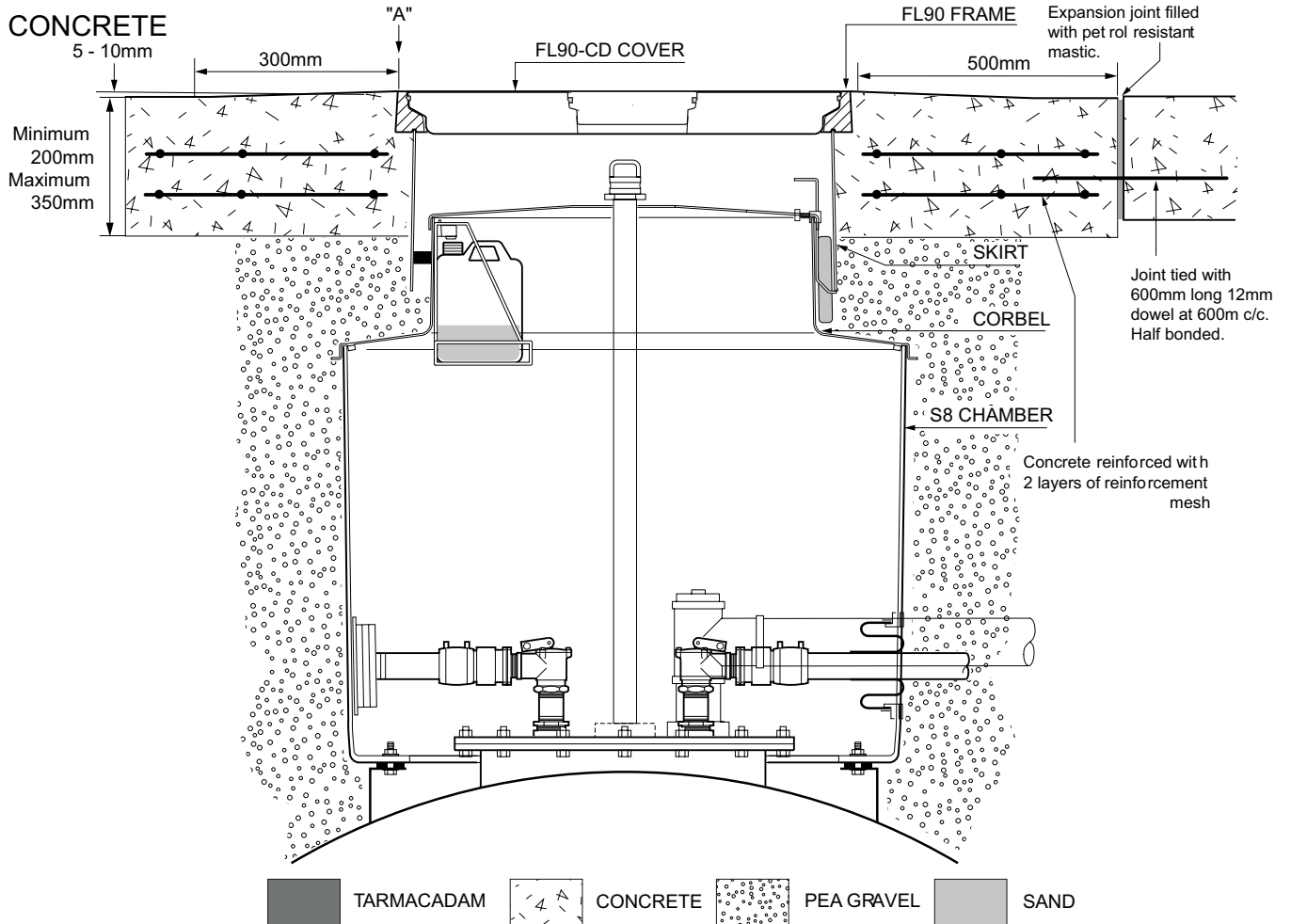

ALTERNATIVE INSTALLATION ADVICE

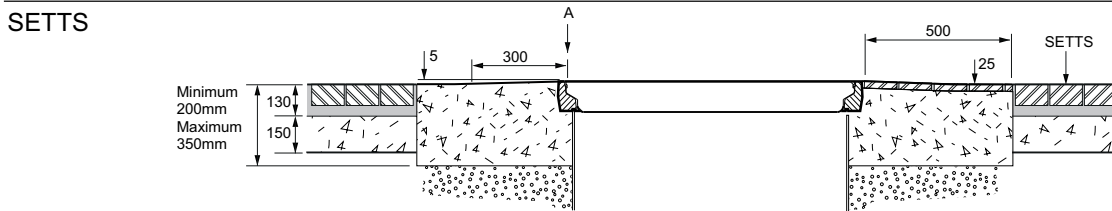
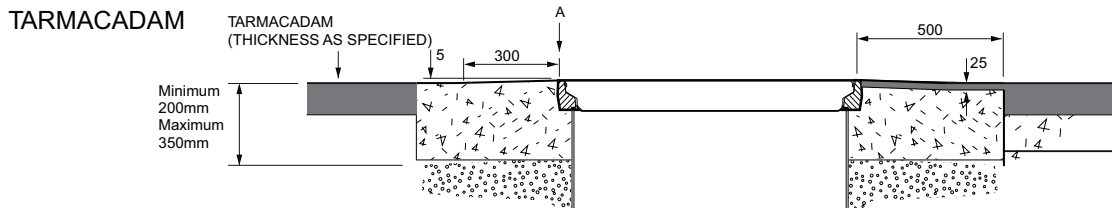

1.2m diameter bolted base chamber with a corbel, adjustable skirt, non-structural internal lid with a central port and round 900mm flat sealed cover with central manual dip cover. Round tank flange.

For reference purposes only. This drawing is not a specification. Order against product code only. To enable continuous improvement of our products, the designs and specifications are subject to change without notice.

FIBRELITE

PART OF OPW A DOVER COMPANY