

1.2m diameter chamber with collar ring base connection, a sealed corbel, watertight platform, adjustable skirt and round 900mm flat sealed cover and composite frame.

For reference purposes only. This drawing is not a specification. Order against product code only. To enable continuous improvement of our products, the designs and specifications are subject to change without notice.

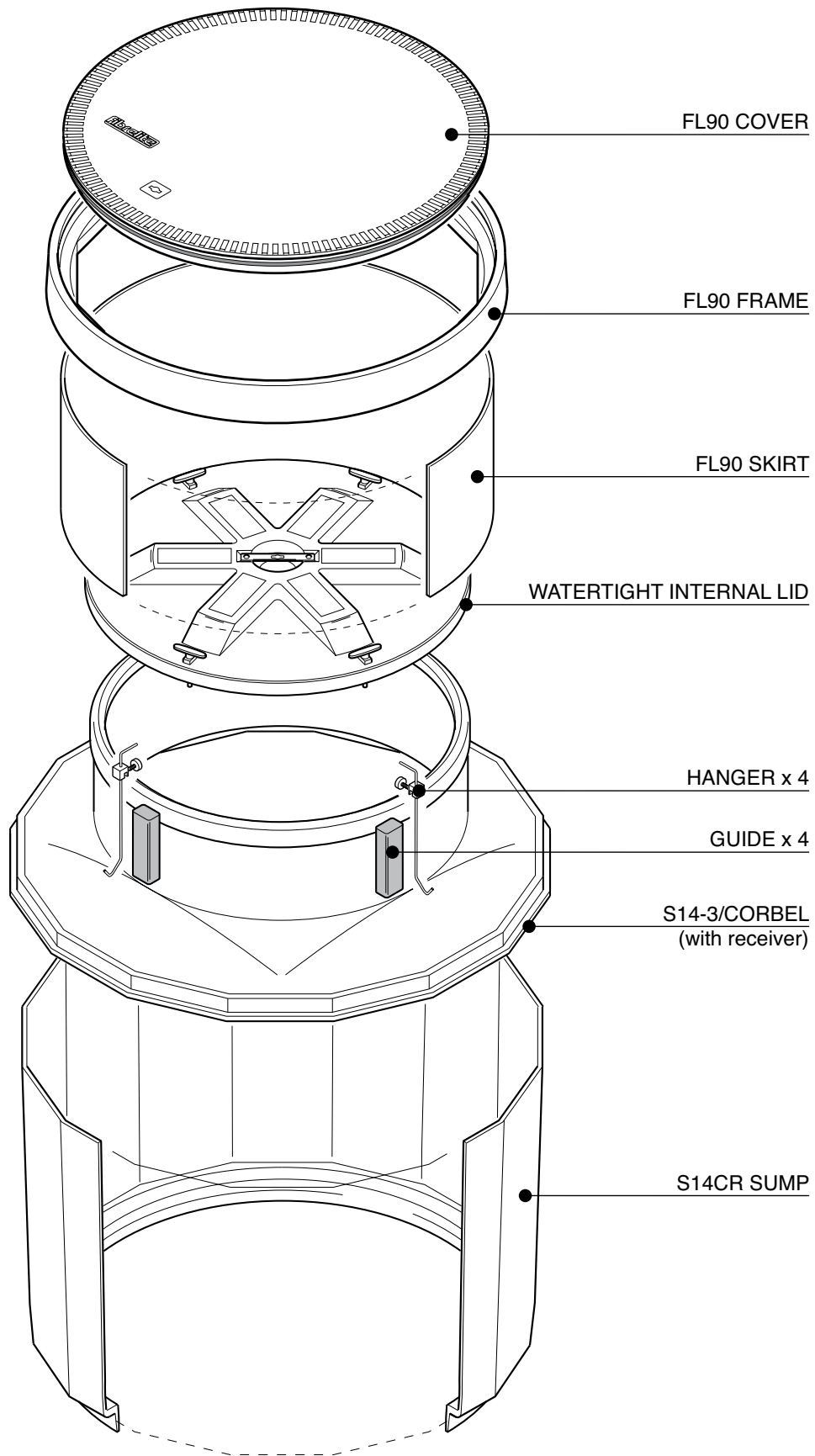

FL90 COVER

FL90 FRAME

FL90 SKIRT

WATERTIGHT INTERNAL LID

HANGER x 4

GUIDE x 4

S14-3/CORBEL  
(with receiver)

S14CR SUMP

1.2m diameter chamber with collar ring base connection, a sealed corbel, watertight platform, adjustable skirt and round 900mm flat sealed cover and composite frame.

For reference purposes only. This drawing is not a specification. Order against product code only. To enable continuous improvement of our products, the designs and specifications are subject to change without notice.



**VERY IMPORTANT**  
 OUTER EDGE "A" OF FRAME SET 5-10mm  
 ABOVE GENERAL GRADE AREA WITH  
 CONCRETE RAMPED AWAY OVER 300mm

TYPICAL INSTALLATION

CONCRETE

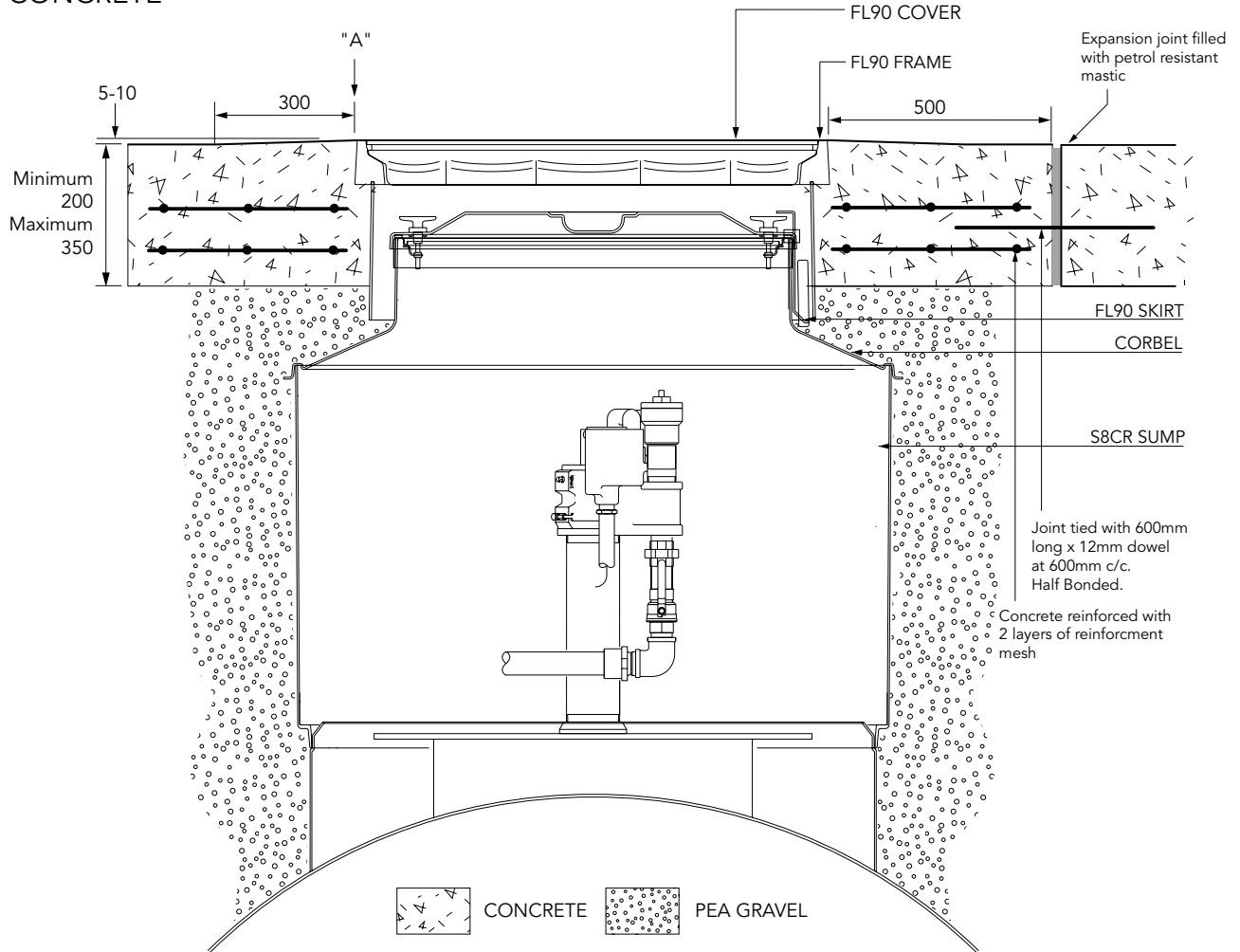

1.2m diameter chamber with collar ring base connection, a sealed corbel, watertight platform, adjustable skirt and round 900mm flat sealed cover and composite frame.

For reference purposes only. This drawing is not a specification. Order against product code only. To enable continuous improvement of our products, the designs and specifications are subject to change without notice.

**FIBRELITE**   
 PART OF OPW A DOWER COMPANY

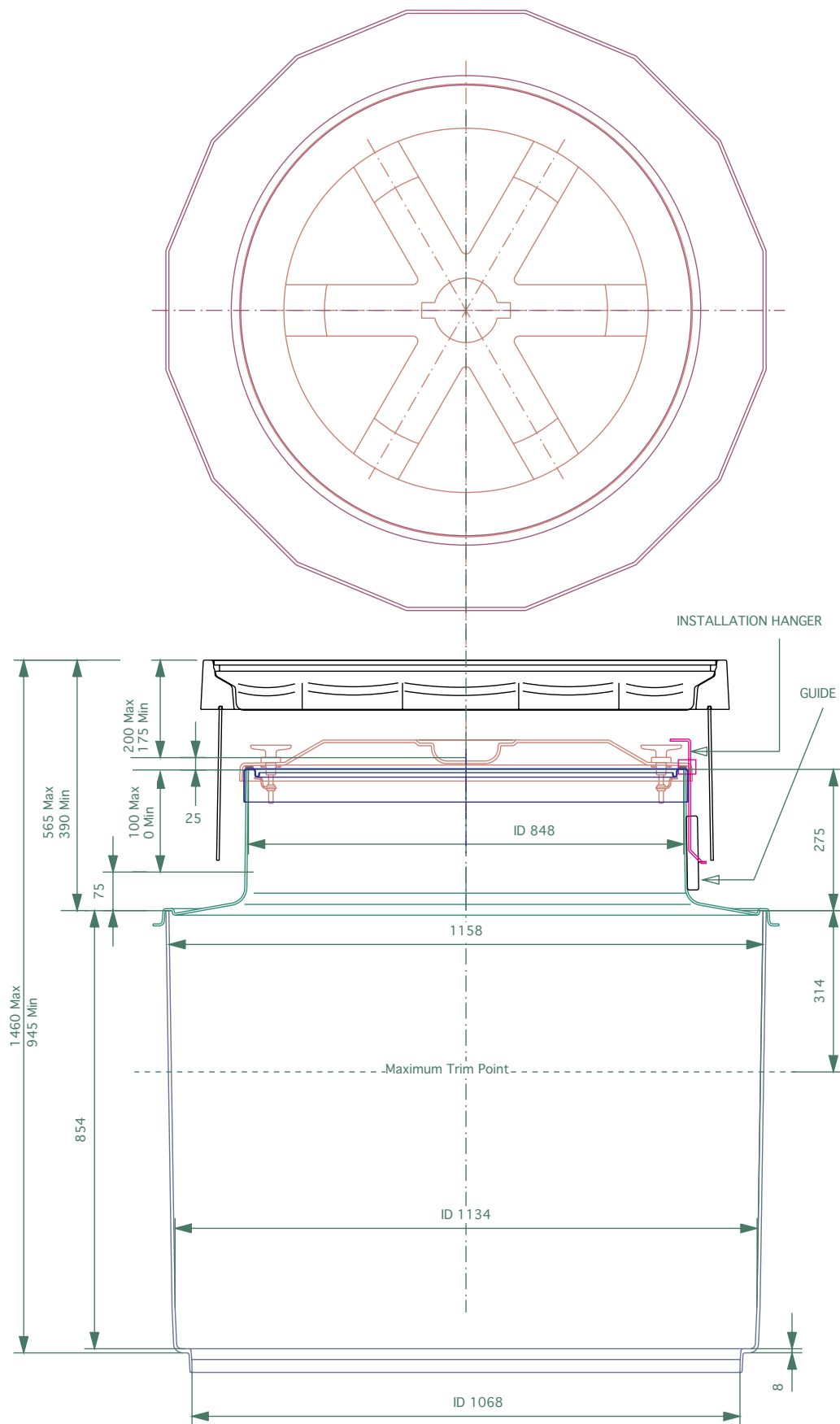

1.2m diameter chamber with collar ring base connection, a sealed corbel, watertight platform, adjustable skirt and round 900mm flat sealed cover and composite frame.

For reference purposes only. This drawing is not a specification. Order against product code only. To enable continuous improvement of our products, the designs and specifications are subject to change without notice.

**FIBRELITE**   
PART OF OPW A DOWDER COMPANY