

43 5/16" x 31 1/2" FRP solid base sump and corbel to fit Wayne Ovation dispenser models.

For reference purposes only. This drawing is not a specification. Order against product code only. To enable continuous improvement of our products, the designs and specifications are subject to change without notice.

FIBRELITE 
PART OF OPW A DOVER COMPANY

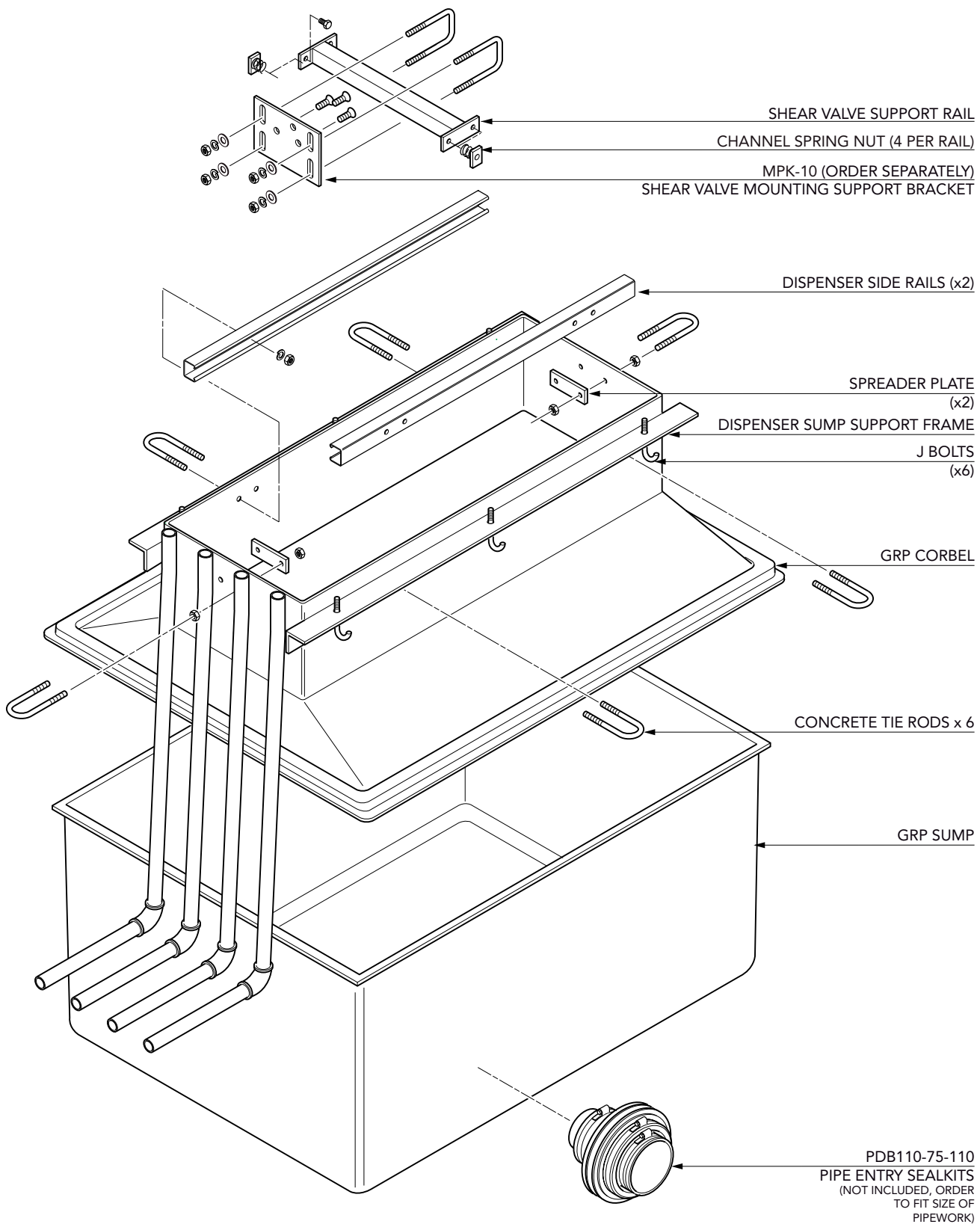

43 5/16" x 31 1/2" FRP solid base sump and corbel to fit Wayne Ovation dispenser models.

For reference purposes only. This drawing is not a specification. Order against product code only. To enable continuous improvement of our products, the designs and specifications are subject to change without notice.



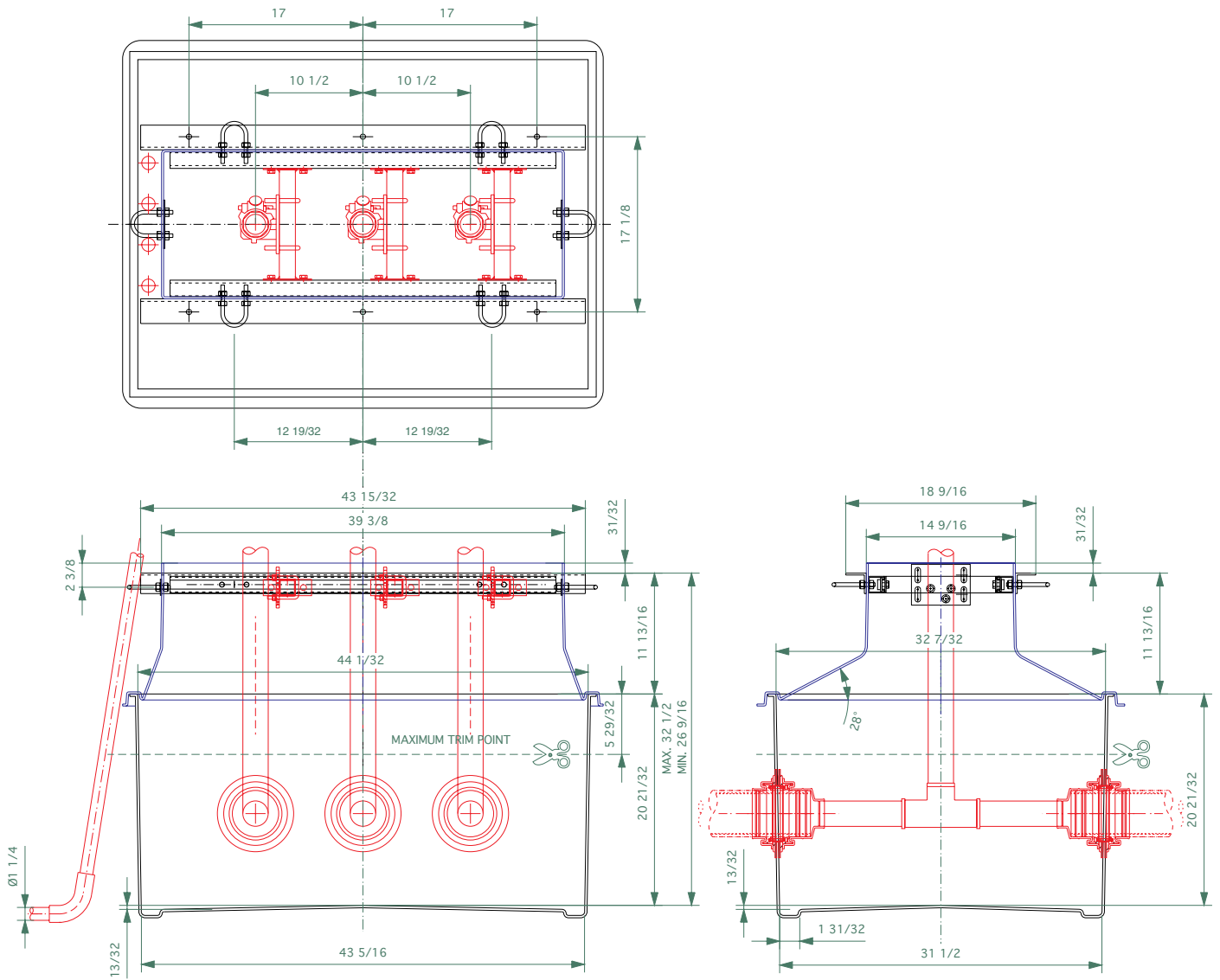

43 5/16" x 31 1/2" FRP solid base sump and corbel to fit Wayne Ovation dispenser models.

For reference purposes only. This drawing is not a specification. Order against product code only. To enable continuous improvement of our products, the designs and specifications are subject to change without notice.

FIBRELITE 
PART OF OPW A DOVER COMPANY