

Manway adaptor plate for 55 1/8" diameter base chamber (S14).

For reference purposes only. This drawing is not a specification. Order against product code only. To enable continuous improvement of our products, the designs and specifications are subject to change without notice.

**FIBRELITE**   
PART OF OPW A DOVER COMPANY

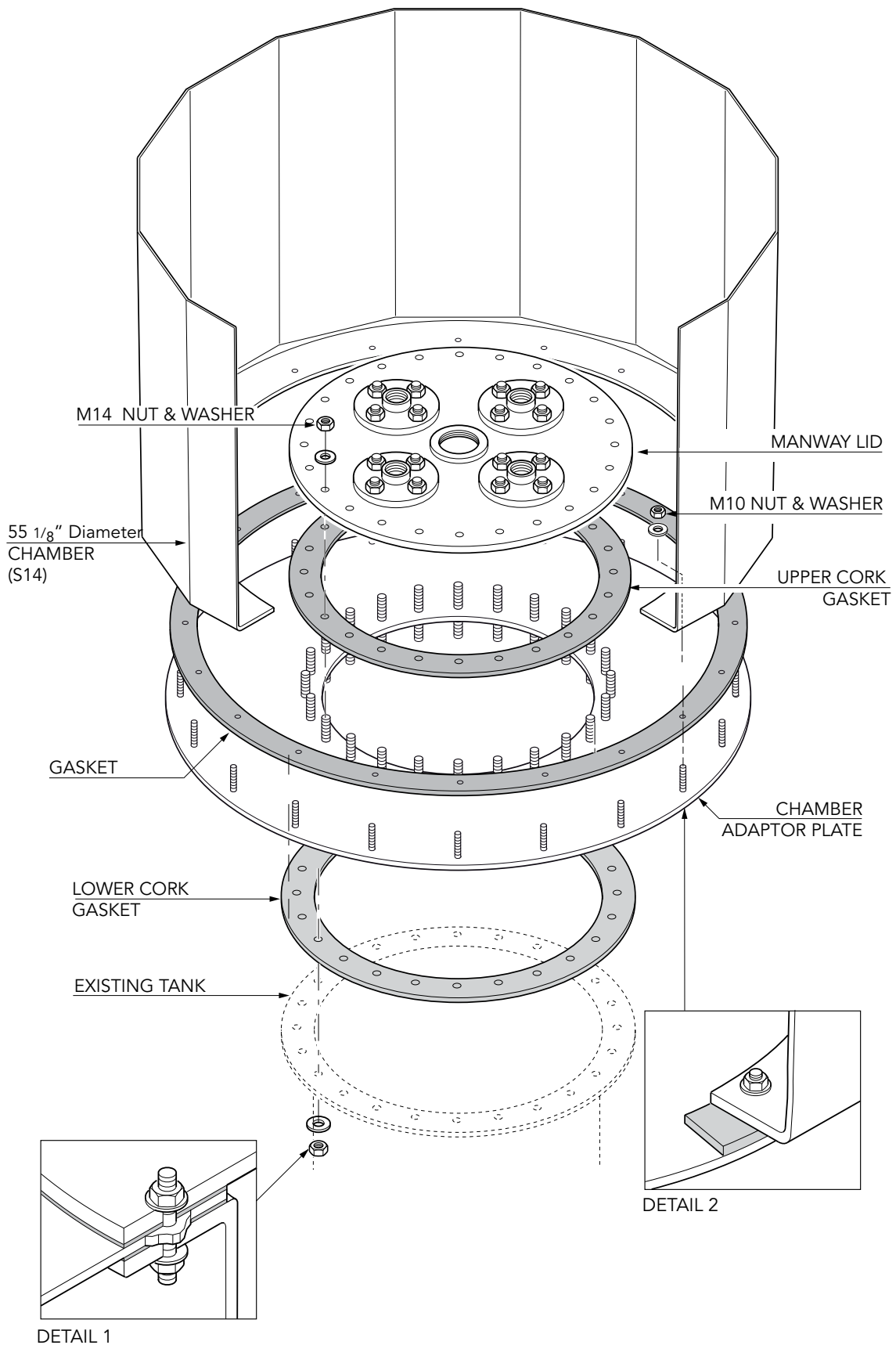

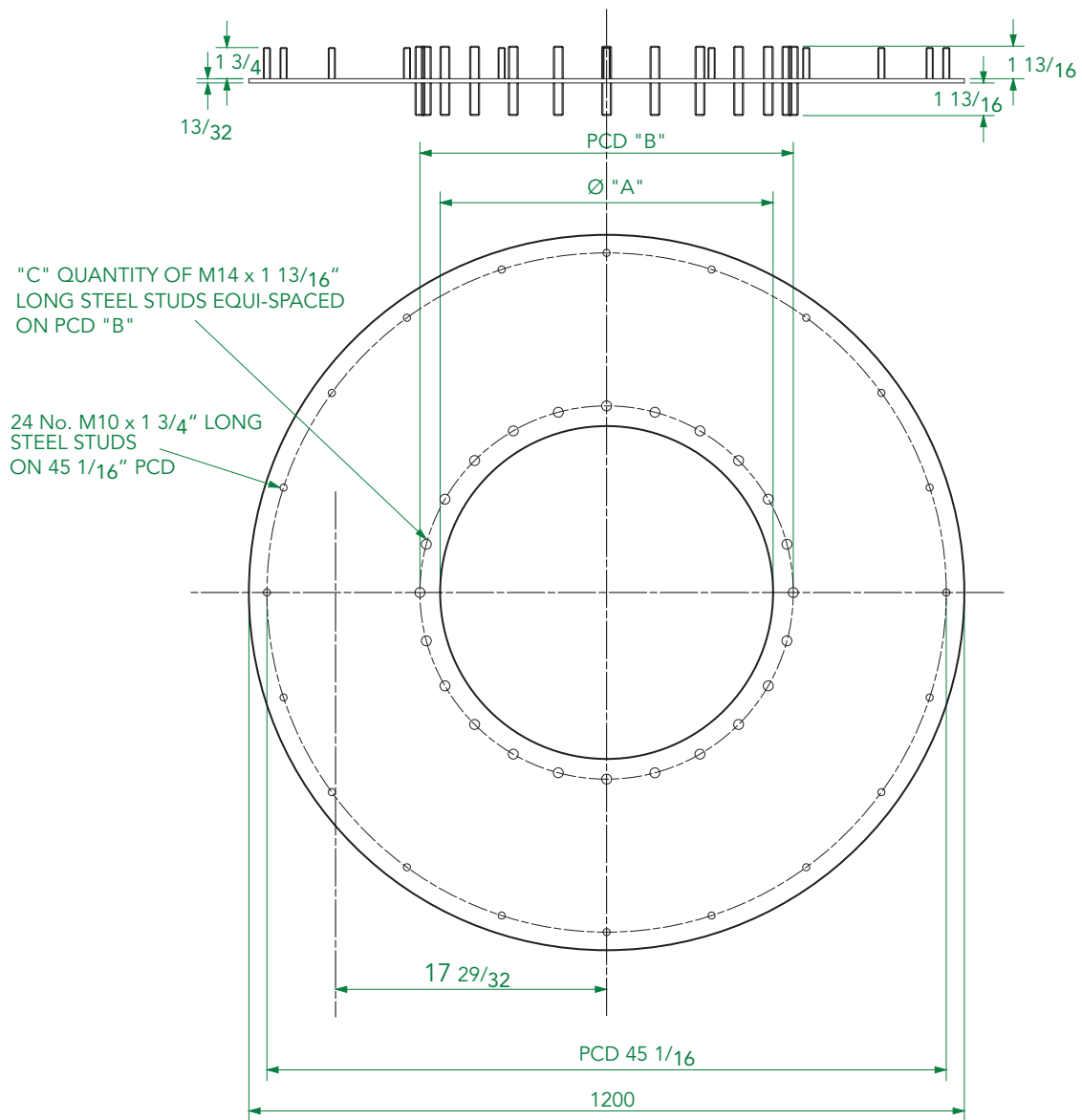

ITEM	NOMINAL SIZE	DIMENSIONS		
		A	B	C
1	18"	18 1/2"	20 3/4"	25/32"
2	18"	18 1/2"	20 7/8"	5/8"
3	24"	24"	26 25/32"	1 15/16"
4	24"	24"	26 25/32"	1 3/32"
5	24"	24"	26 25/32"	1 1/4"

Material: Steel, zinc plated