

40" dia. watertight flat sealed composite cover with removable offset dip cover (10" dia.) and frame.

For reference purposes only. This drawing is not a specification. Order against product code only. To enable continuous improvement of our products, the designs and specifications are subject to change without notice.

FIBRELITE 
PART OF OPW A  COMPANY

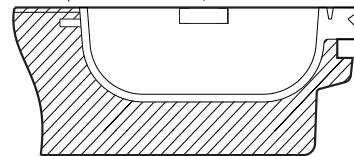
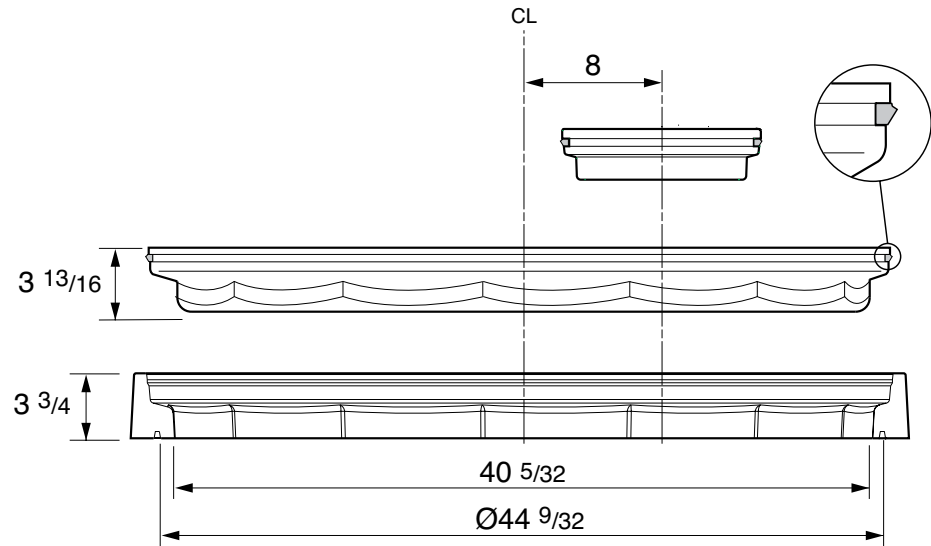
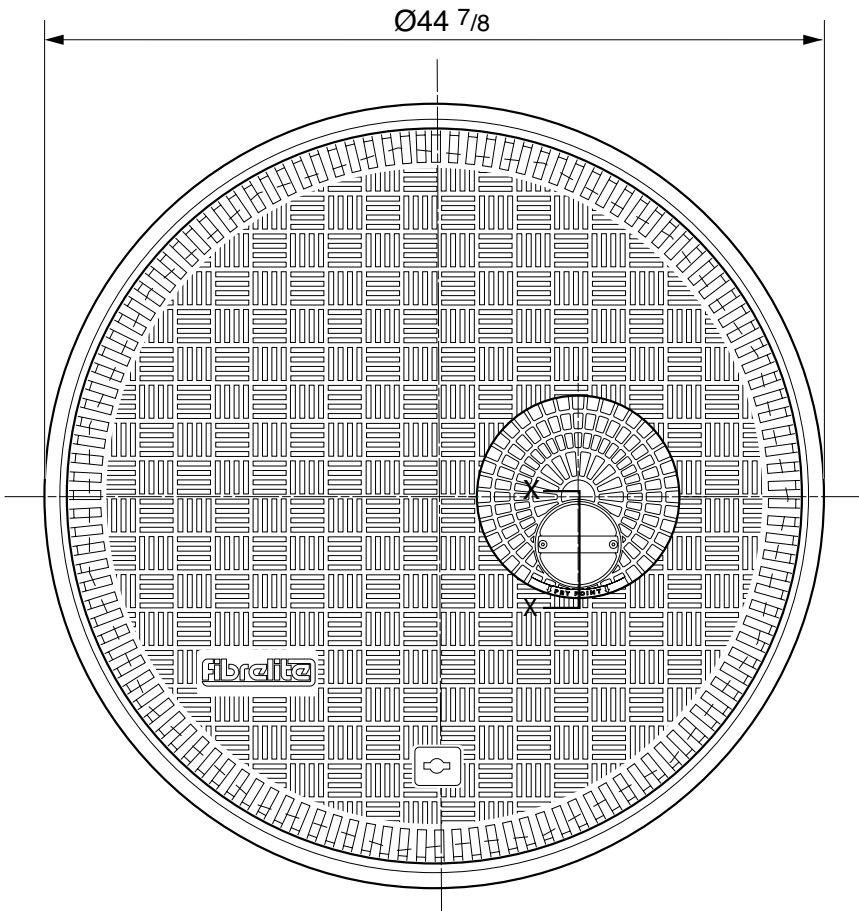
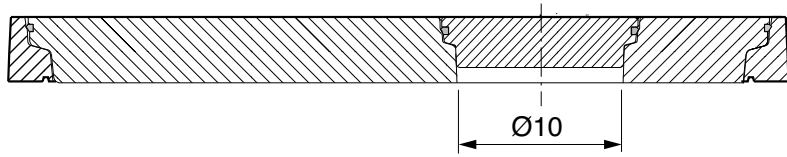

SECTION X - X
HANDLE BOWL

Load Rating	Cover Weight (lbs)	Frame Weight (lbs)	Port Cover Weight (lbs)
SD	108	22	7
HD	117	22	7

40" dia. watertight flat sealed composite cover with removable offset dip cover (10" dia.) and frame.

For reference purposes only. This drawing is not a specification. Order against product code only. To enable continuous improvement of our products, the designs and specifications are subject to change without notice.



CONCRETE

VERY IMPORTANT

OUTER EDGE "A" OF FRAME SET 1/4 - 1/2" ABOVE GENERAL GRADE AREA WITH CONCRETE RAMPED AWAY OVER 12"

VERY IMPORTANT

The underside of the frame must be adequately supported by concrete.

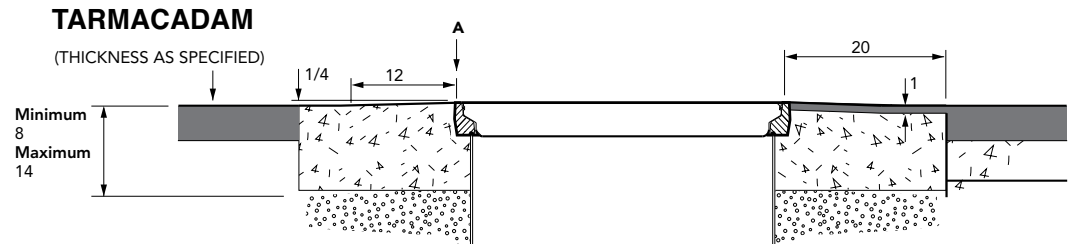
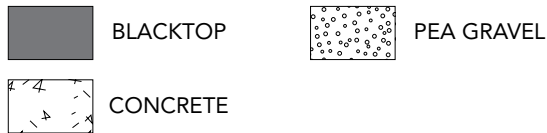
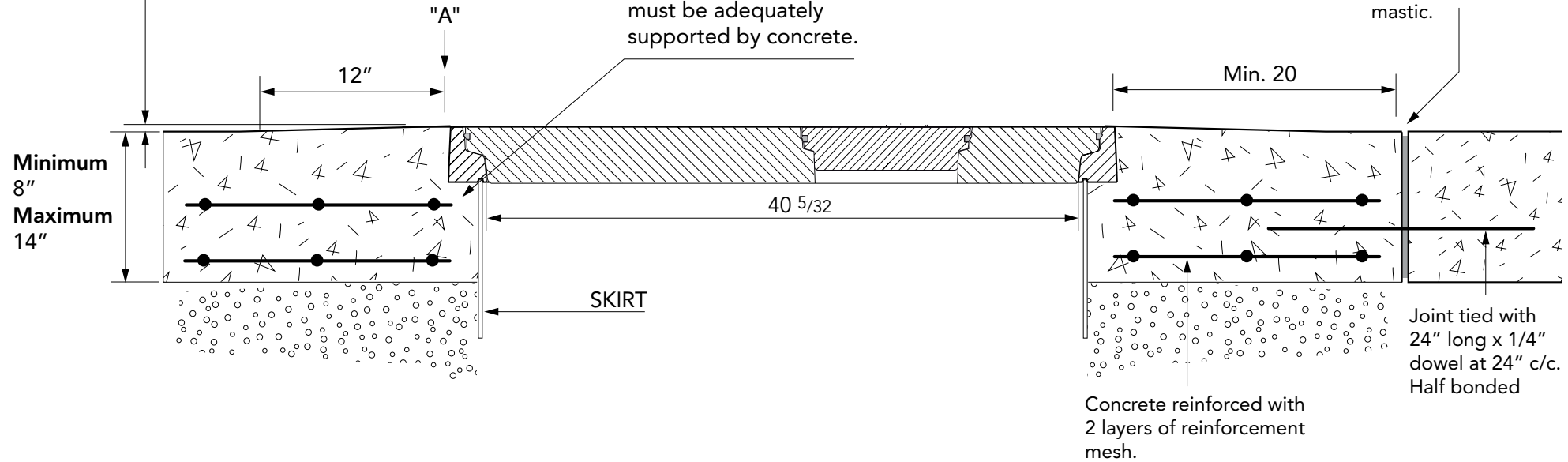

40" dia. watertight flat sealed composite cover with removable offset dip cover (10" dia.) and frame.

For reference purposes only. This drawing is not a specification. Order against product code only. To enable continuous improvement of our products, the designs and specifications are subject to change without notice.

FIBRELITE 
PART OF OPW A DOWDER COMPANY