

59 1/16" dia twelve sided sump with collar ring base. corbel, skirt, non structural internal lid with dipstick hole. 42" dia flat sealed black cover with central sealed cover and frame. Designed for a remote fill line with a central dip.

For reference purposes only. This drawing is not a specification. Order against product code only. To enable continuous improvement of our products, the designs and specifications are subject to change without notice.

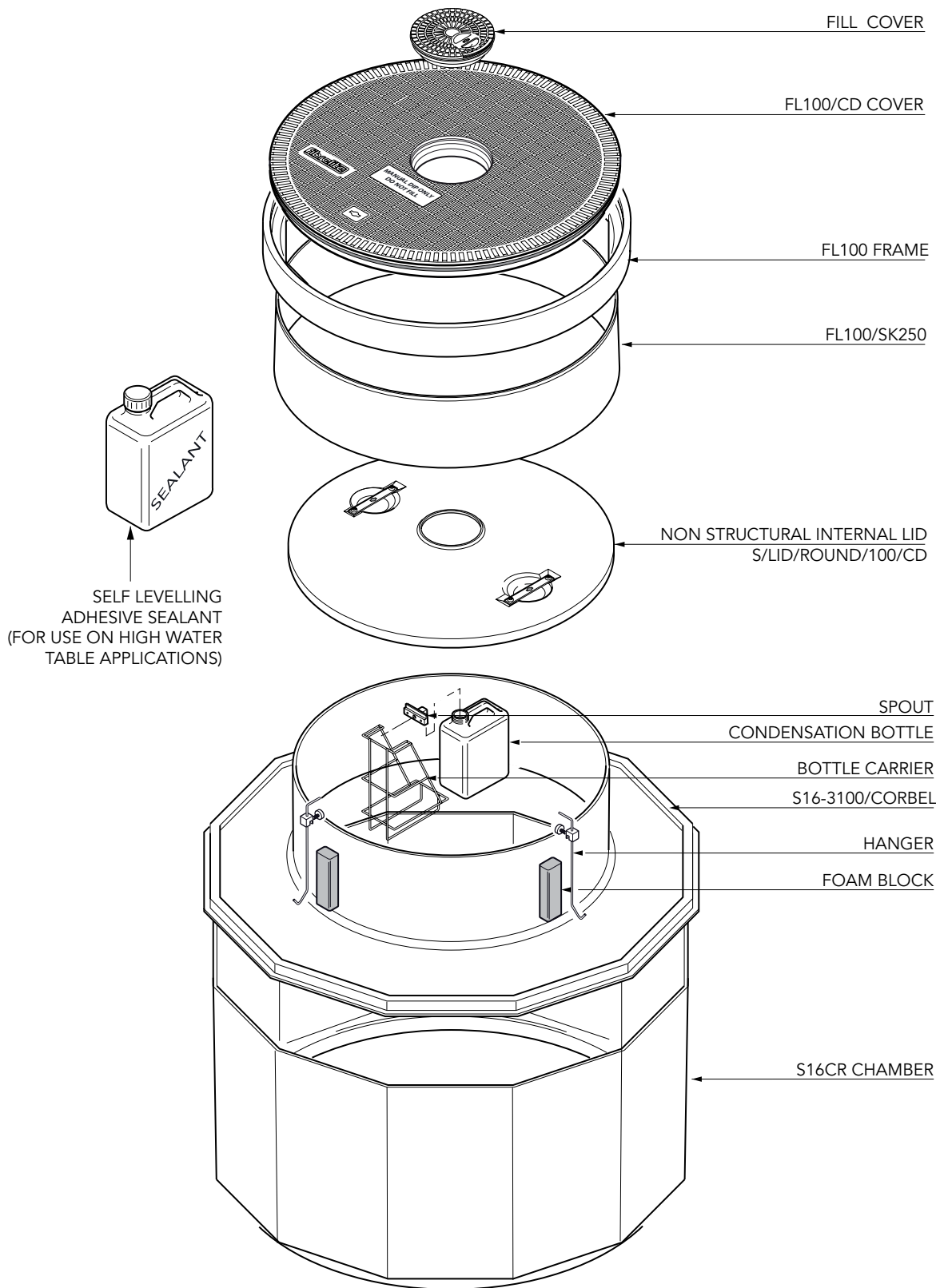

59 1/16" dia twelve sided sump with collar ring base. corbel, skirt, non structural internal lid with dipstick hole. 42" dia flat sealed black cover with central sealed cover and frame. Designed for a remote fill line with a central dip.

For reference purposes only. This drawing is not a specification. Order against product code only. To enable continuous improvement of our products, the designs and specifications are subject to change without notice.

FIBRELITE 
PART OF OPW A DOWDER COMPANY

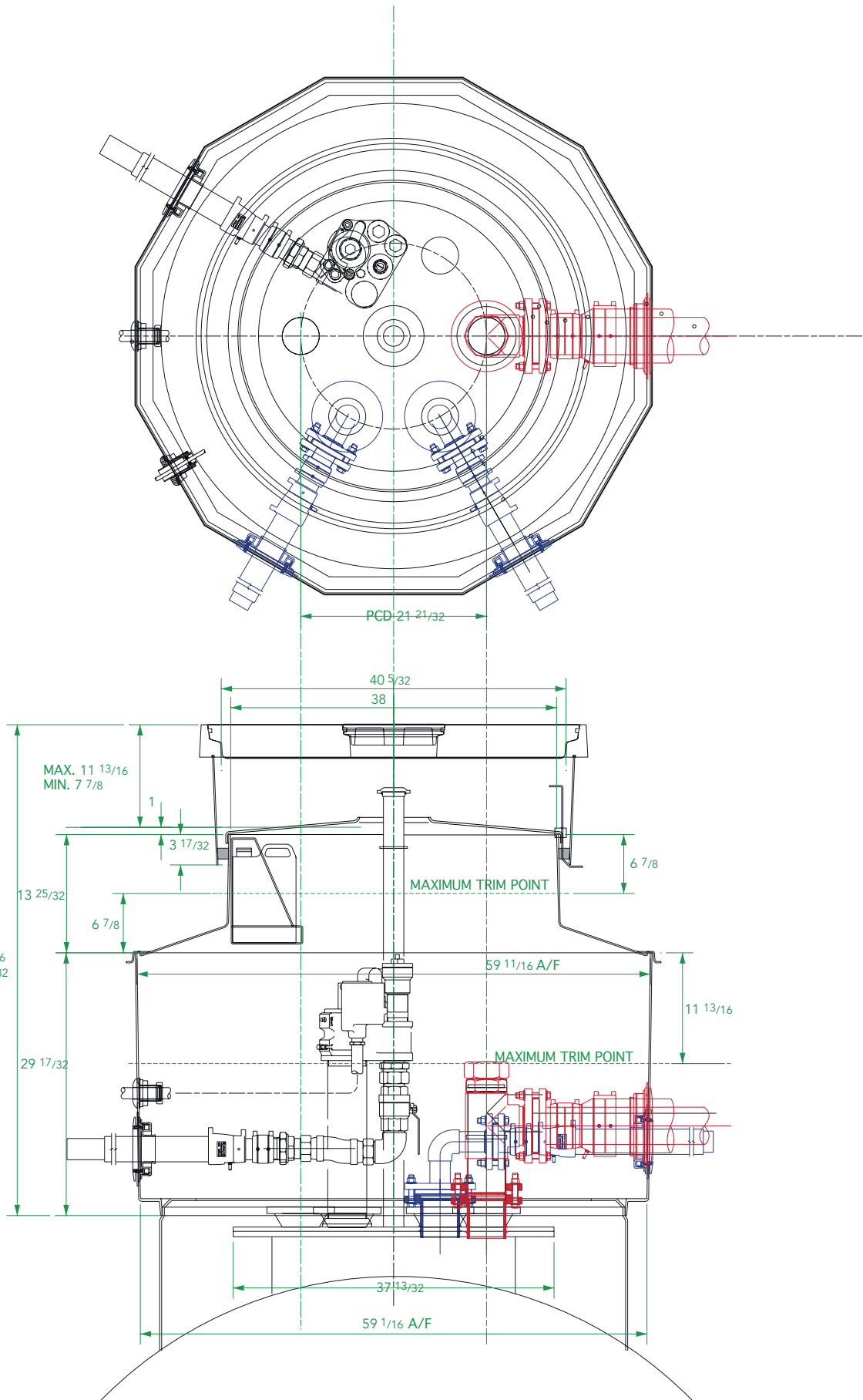

59 1/16" dia twelve sided sump with collar ring base. corbel, skirt, non structural internal lid with dipstick hole. 42" dia flat sealed black cover with central sealed cover and frame. Designed for a remote fill line with a central dip.

For reference purposes only. This drawing is not a specification. Order against product code only. To enable continuous improvement of our products, the designs and specifications are subject to change without notice.

FIBRELITE 
 PART OF OPW A DOVER COMPANY

VERY IMPORTANT
 OUTER EDGE "A" OF FRAME SET $3/16"$ - $13/32"$
 ABOVE GENERAL FORECOURT AREA WITH
 CONCRETE RAMPED AWAY OVER $11\ 13/16"$.

TYPICAL INSTALLATION

CONCRETE

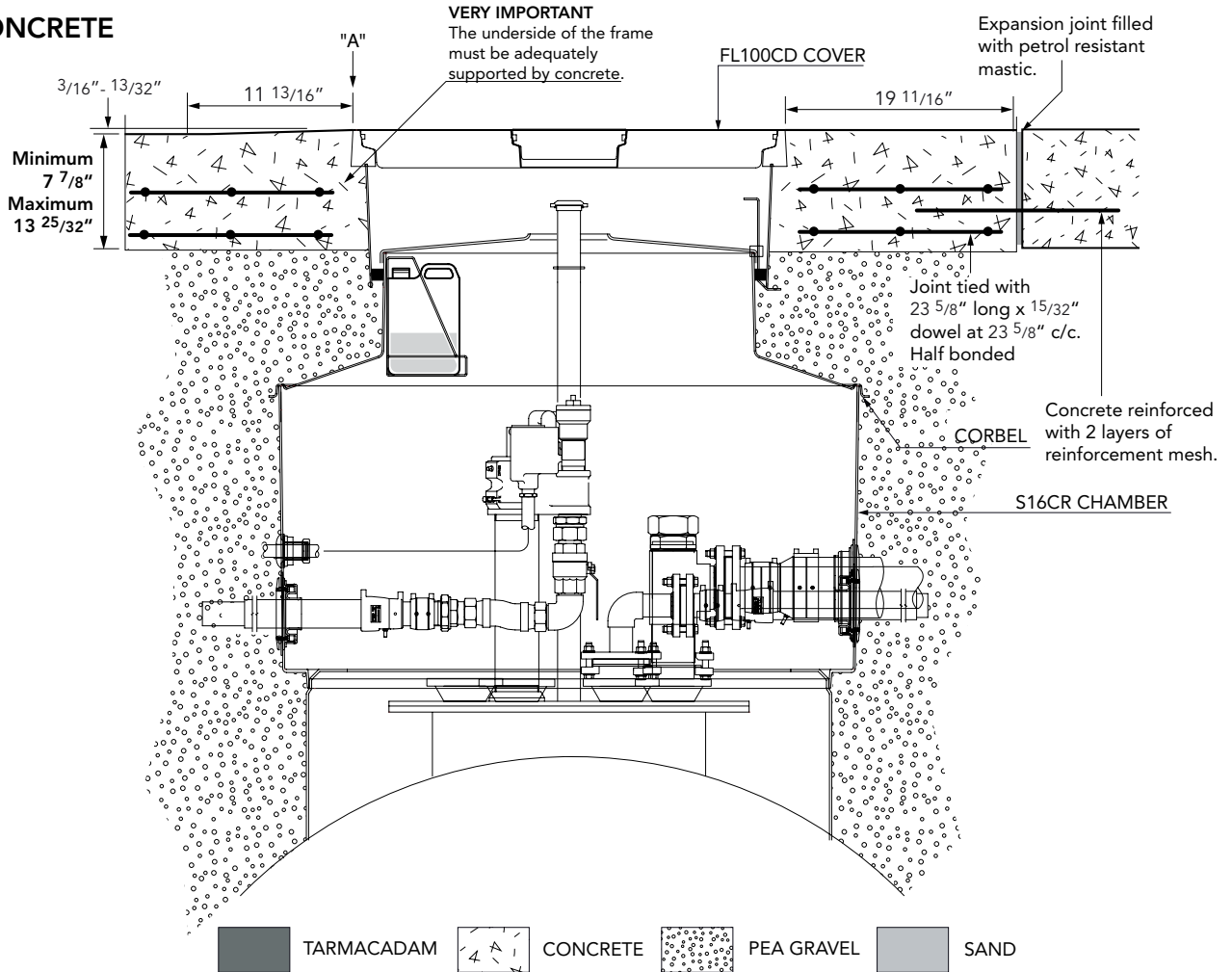

ALTERNATIVE INSTALLATION ADVICE

TARMACADAM

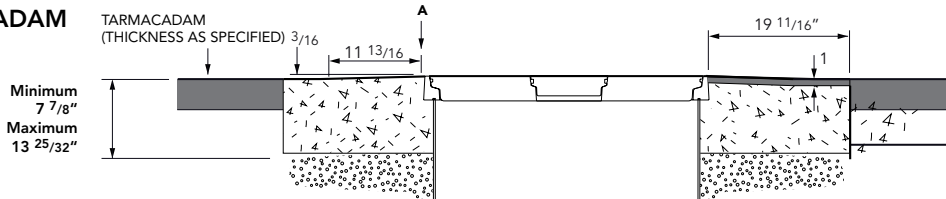

SETTS

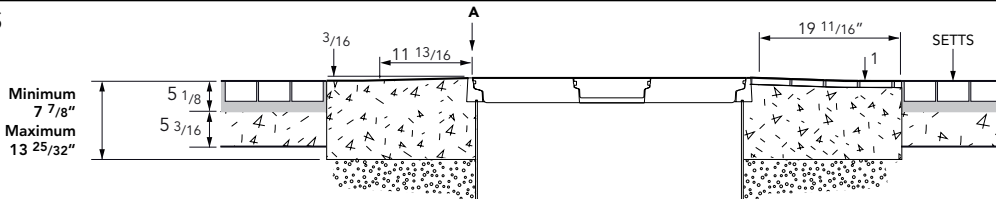

59 1/16" dia twelve sided sump with collar ring base. corbel, skirt, non structural internal lid with dipstick hole. 42" dia flat sealed black cover with central sealed cover and frame. Designed for a remote fill line with a central dip.

For reference purposes only. This drawing is not a specification. Order against product code only. To enable continuous improvement of our products, the designs and specifications are subject to change without notice.

