

20" square x 24" deep FRP solid base sump, FRP spill container, FRP skirt, 30" dia flat sealed cover and frame. 1/2 tin sealant. 1 Fill and 1 VR1B

For reference purposes only. This drawing is not a specification. Order against product code only. To enable continuous improvement of our products, the designs and specifications are subject to change without notice.

FIBRELITE 
PART OF OPW A DOVER COMPANY

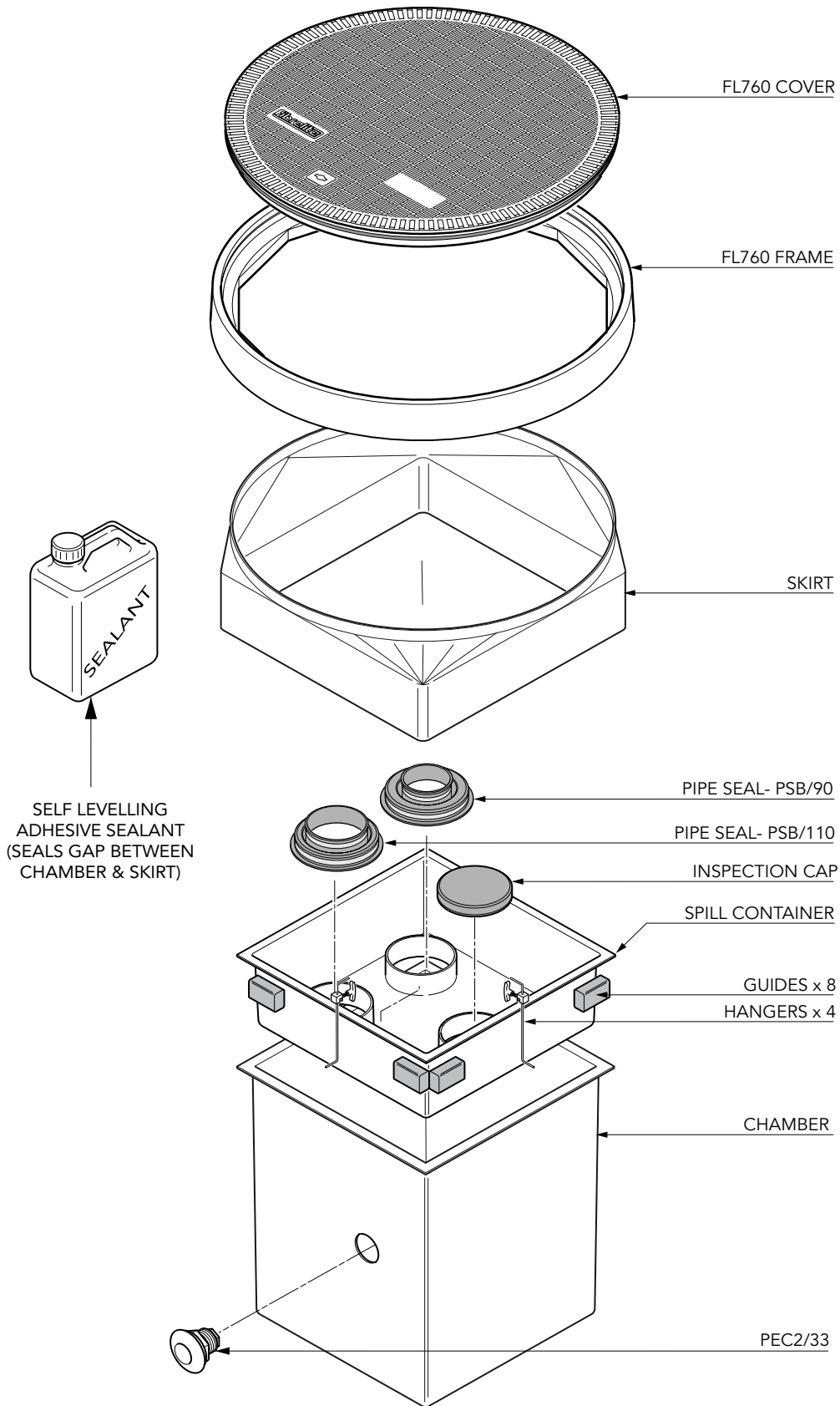

20" square x 24" deep FRP solid base sump, FRP spill container, FRP skirt, 30" dia flat sealed cover and frame. ½ tin sealant. 1 Fill and 1 VR1B

For reference purposes only. This drawing is not a specification. Order against product code only. To enable continuous improvement of our products, the designs and specifications are subject to change without notice.

FIBRELITE 
PART OF OPW A DOVER COMPANY

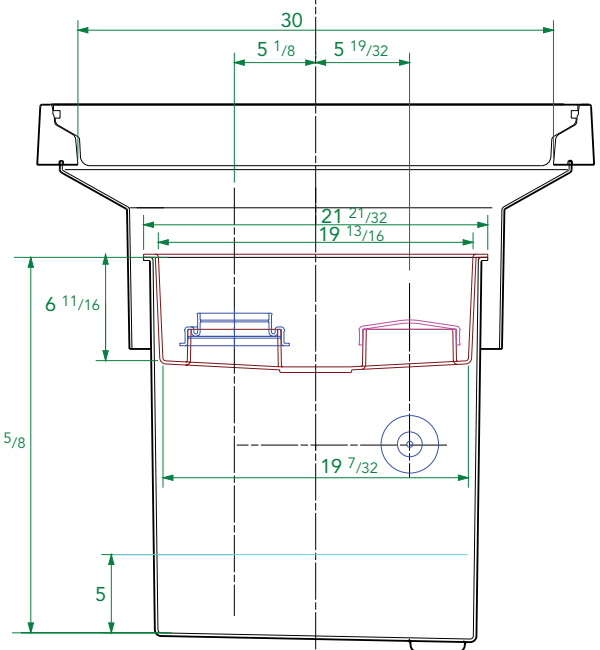
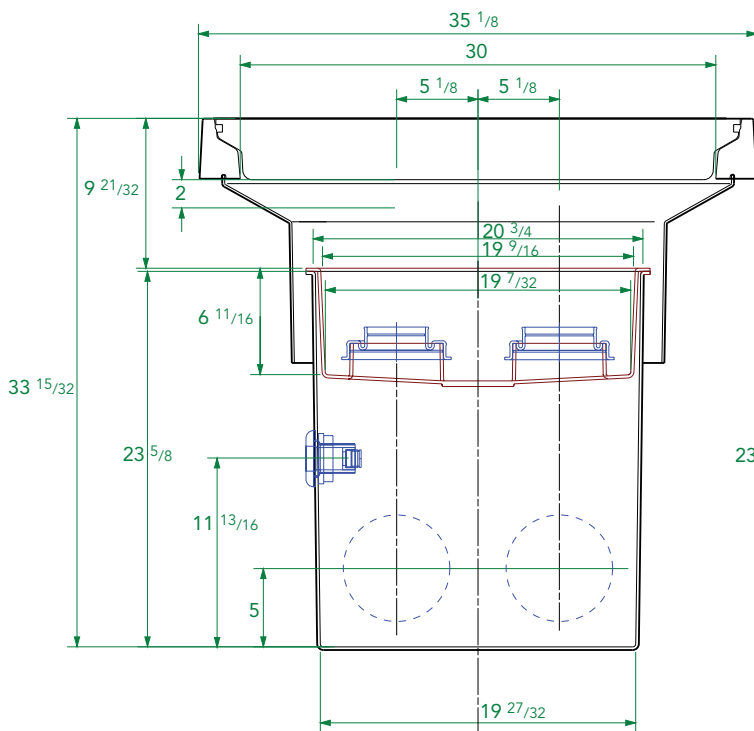
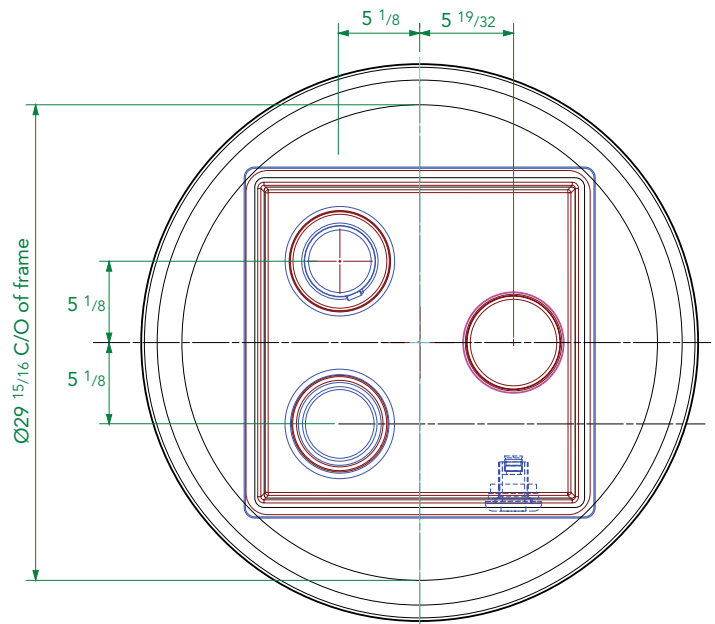

20" square x 24" deep FRP solid base sump, FRP spill container, FRP skirt, 30" dia flat sealed cover and frame. 1/2 tin sealant. 1 Fill and 1 VR1B

For reference purposes only. This drawing is not a specification. Order against product code only. To enable continuous improvement of our products, the designs and specifications are subject to change without notice.

FIBRELITE 
PART OF OPW A DOWDER COMPANY

TYPICAL INSTALLATION

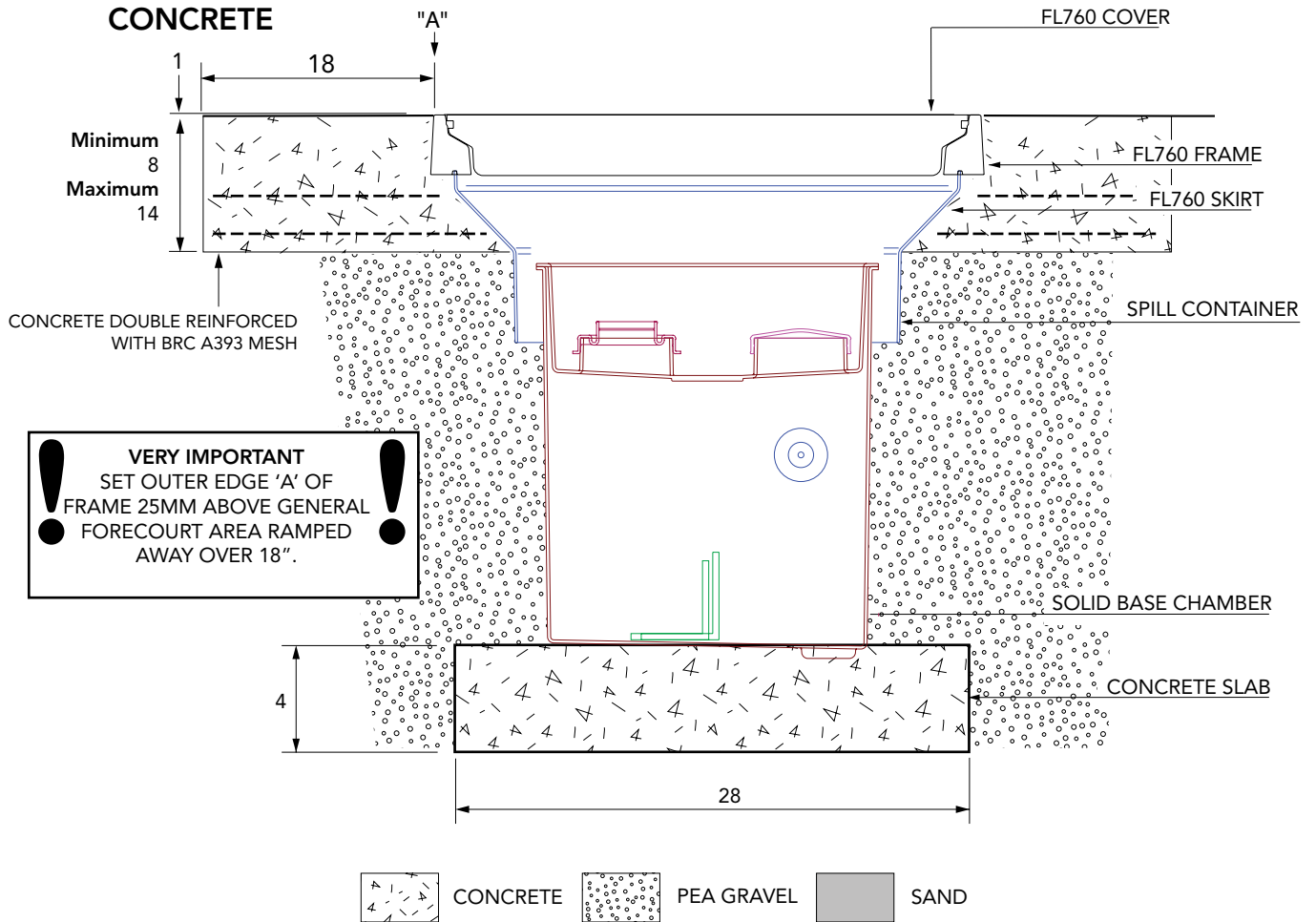

ALTERNATIVE INSTALLATION ADVICE

TARMACADAM

