

45" diameter x 33" deep sump base to fit 42" tank collar ring, corbel and watertight spill platform for (2) 5-gallon spill buckets. 36" diameter multiport cover, frame and skirt.

For reference purposes only. This drawing is not a specification. Order against product code only. To enable continuous improvement of our products, the designs and specifications are subject to change without notice.

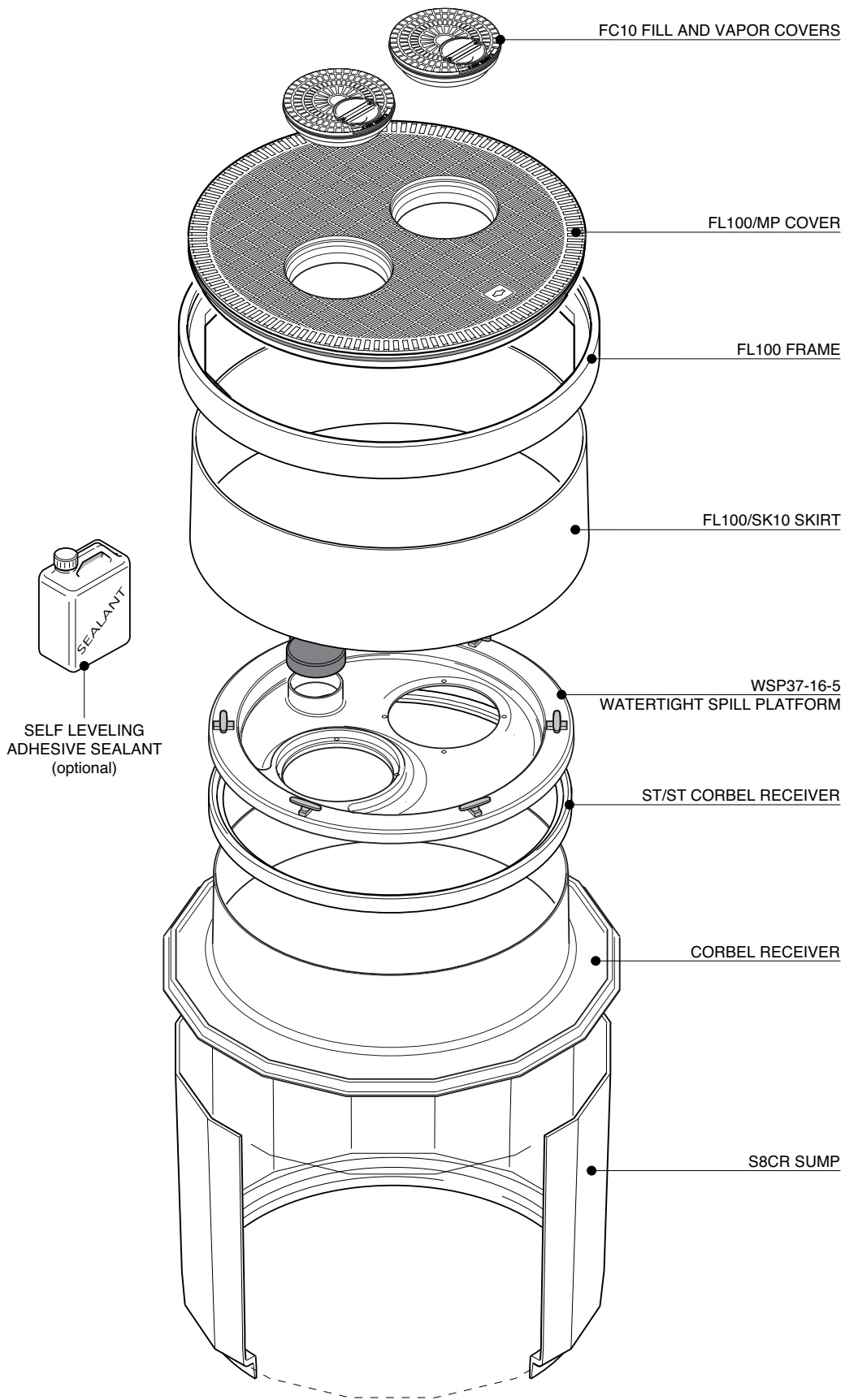

45" diameter x 33" deep sump base to fit 42" tank collar ring, corbel and watertight spill platform for (2) 5-gallon spill buckets. 36" diameter multiport cover, frame and skirt.

For reference purposes only. This drawing is not a specification. Order against product code only. To enable continuous improvement of our products, the designs and specifications are subject to change without notice.

FIBRELITE 
PART OF OPW A DOWDER COMPANY

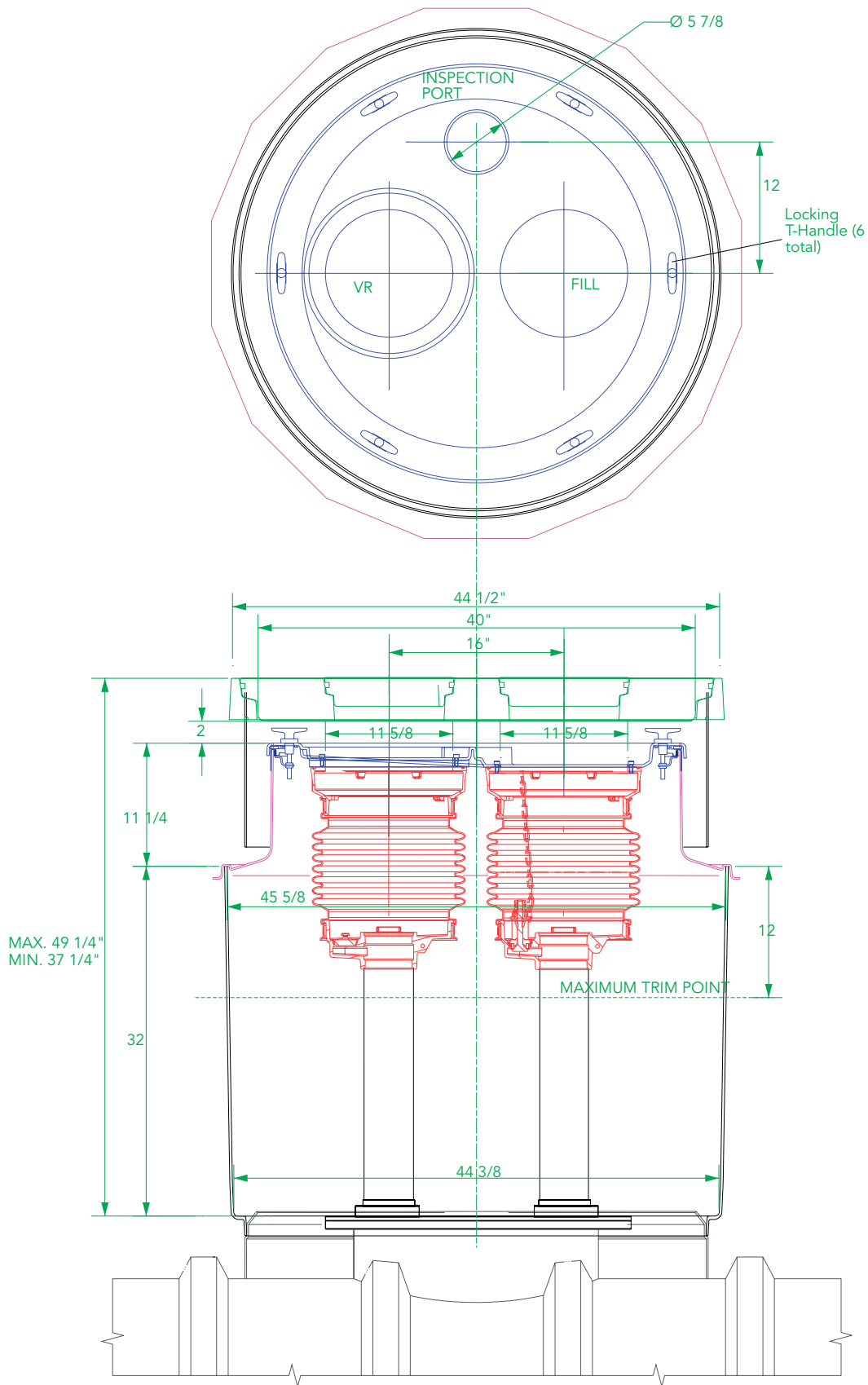

45" diameter x 33" deep sump base to fit 42" tank collar ring, corbel and watertight spill platform for (2) 5-gallon spill buckets. 36" diameter multiport cover, frame and skirt.

For reference purposes only. This drawing is not a specification. Order against product code only. To enable continuous improvement of our products, the designs and specifications are subject to change without notice.

FIBRELITE 
PART OF OPW A DOVER COMPANY

TYPICAL INSTALLATION

VERY IMPORTANT

To allow for drainage, Fibrelite recommends that the concrete be sloped away from the top outer edge of the frame (A) a minimum of 1/2" over a 12" distance. Do not expose the top outer edge of the frame (A) – the concrete pad must be flush with the top outer edge of the frame.

CONCRETE

VERY IMPORTANT

FRAMES MUST BE INSTALLED FLUSH WITH FINISHED GRADE OR SET SLIGHTLY BELOW FINISHED GRADE TO PROTECT FROM SNOWPLOW DAMAGE

VERY IMPORTANT

The underside of the frame must be adequately supported by concrete.

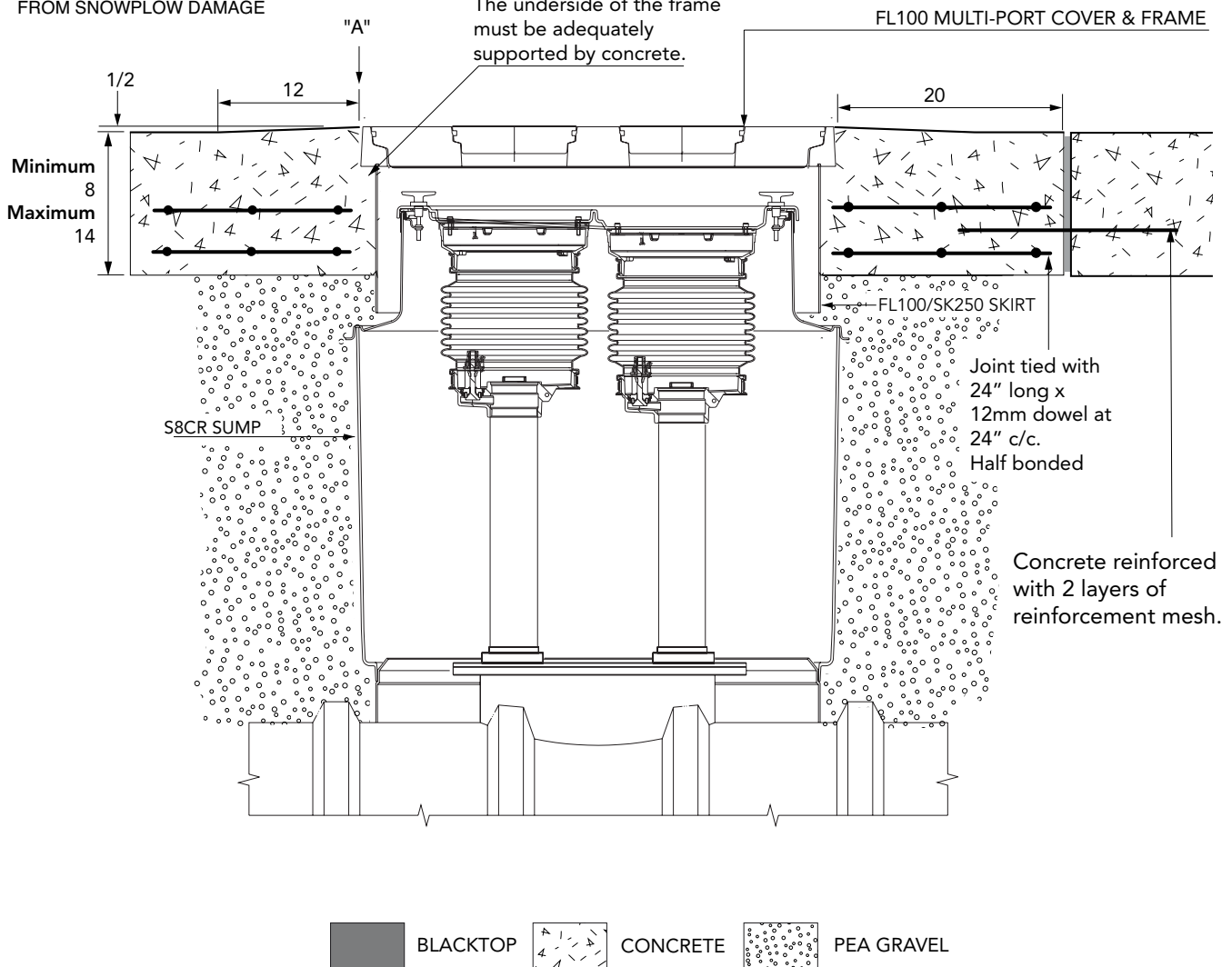

45" diameter x 33" deep sump base to fit 42" tank collar ring, corbel and watertight spill platform for (2) 5-gallon spill buckets. 36" diameter multiport cover, frame and skirt.

For reference purposes only. This drawing is not a specification. Order against product code only. To enable continuous improvement of our products, the designs and specifications are subject to change without notice.

FIBRELITE

PART OF OPW A DOVER COMPANY