

45" diameter sump to fit 42" tank collar ring with corbel, internal lid, adjustable skirt and round 36" offset dip flat sealed cover, corbel/skirt sealkit with condensation bottle and fixing kit.

For reference purposes only. This drawing is not a specification. Order against product code only. To enable continuous improvement of our products, the designs and specifications are subject to change without notice.

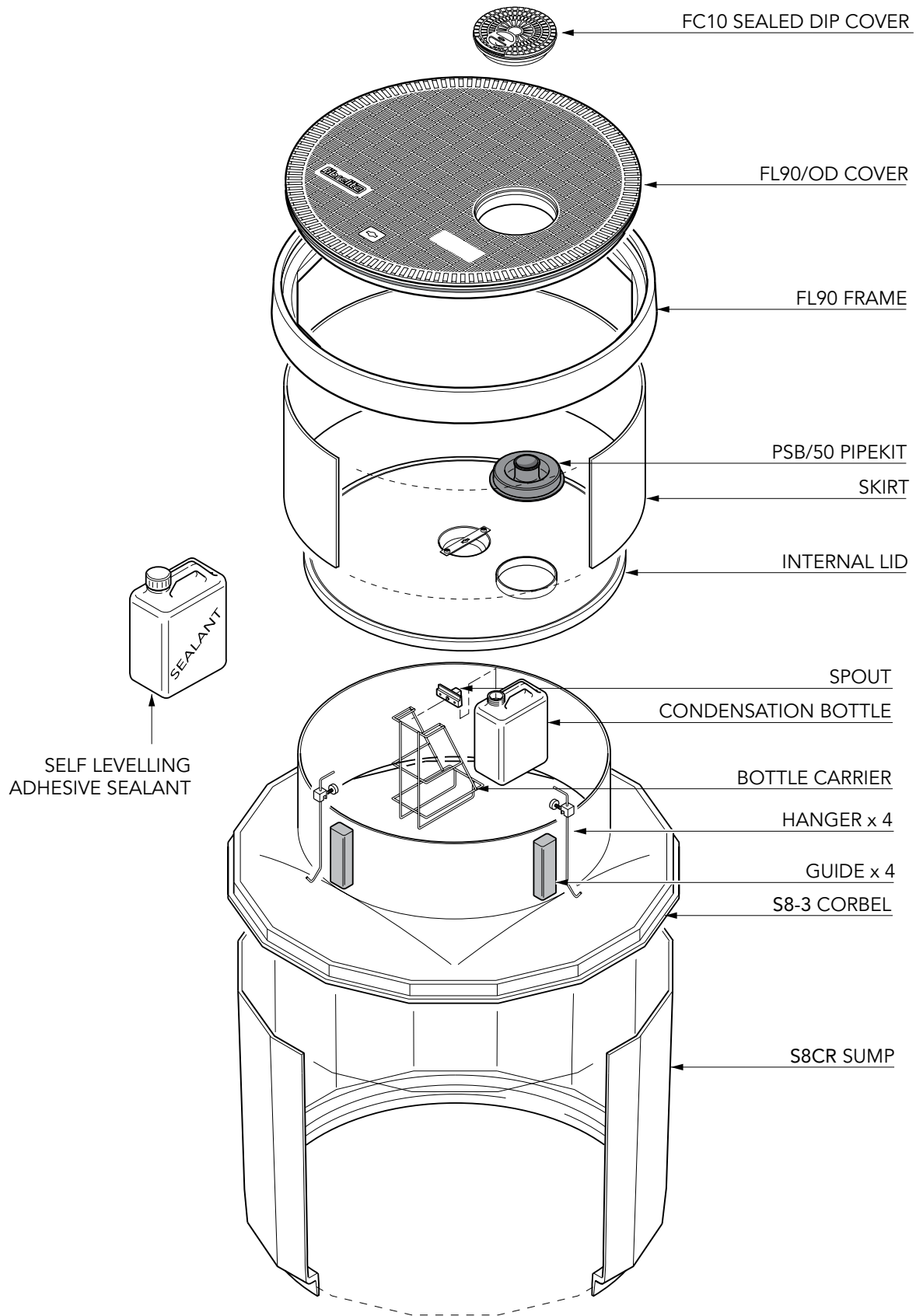

45" diameter sump to fit 42" tank collar ring with corbel, internal lid, adjustable skirt and round 36" offset dip flat sealed cover, corbel/skirt sealkit with condensation bottle and fixing kit.

For reference purposes only. This drawing is not a specification. Order against product code only. To enable continuous improvement of our products, the designs and specifications are subject to change without notice.

FIBRELITE 
PART OF OPW A  COMPANY

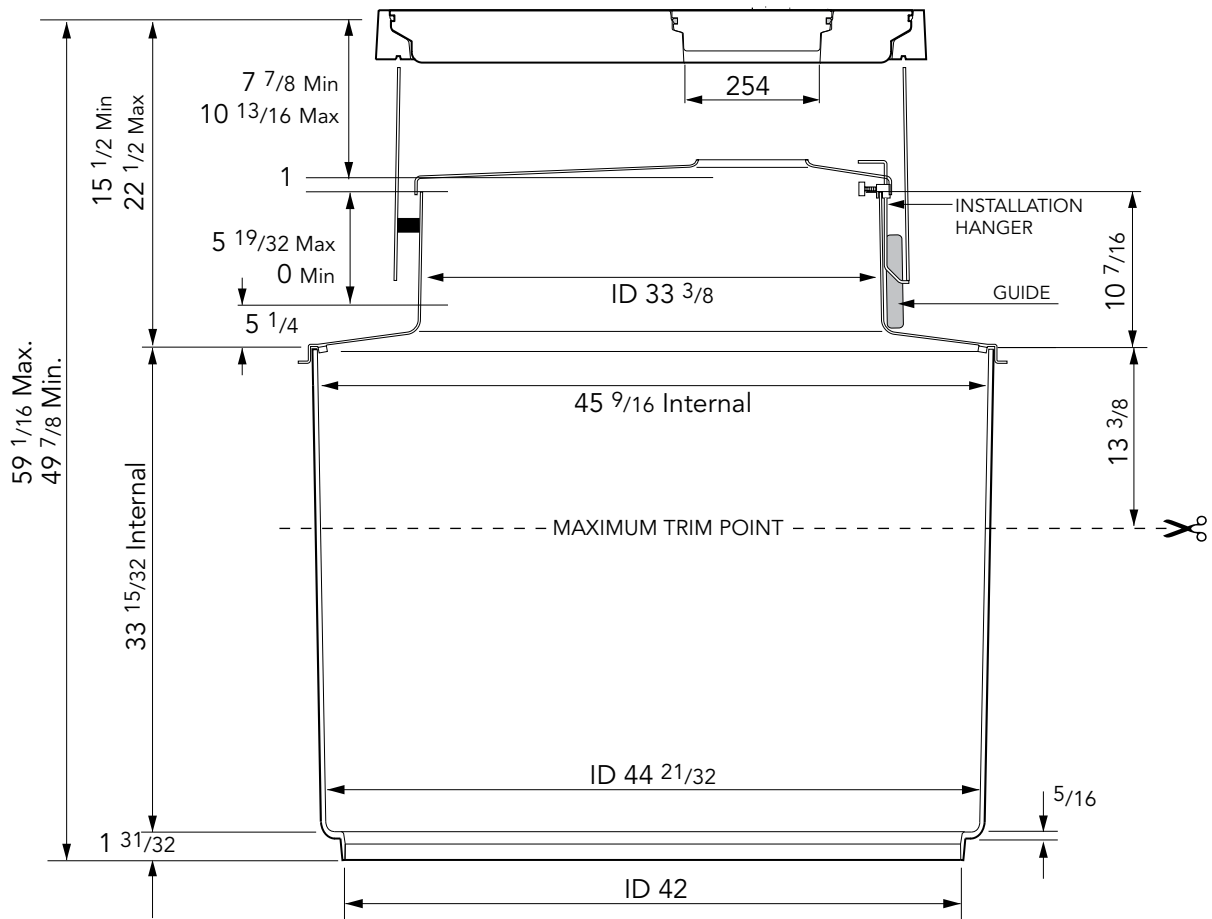
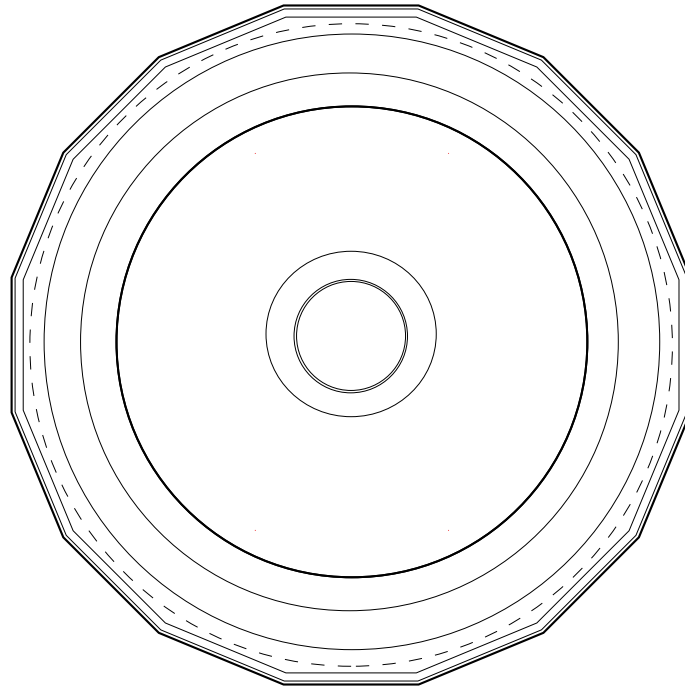

45" diameter sump to fit 42" tank collar ring with corbel, internal lid, adjustable skirt and round 36" offset dip flat sealed cover, corbel/skirt sealkit with condensation bottle and fixing kit.

For reference purposes only. This drawing is not a specification. Order against product code only. To enable continuous improvement of our products, the designs and specifications are subject to change without notice.

FIBRELITE 

PART OF OPW A DOVER COMPANY

VERY IMPORTANT
 OUTER EDGE "A" OF FRAME SET $\frac{1}{4}$ - $\frac{1}{2}$ "
 ABOVE GENERAL GRADE AREA WITH
 CONCRETE RAMPED AWAY OVER 12".

TYPICAL INSTALLATION

CONCRETE

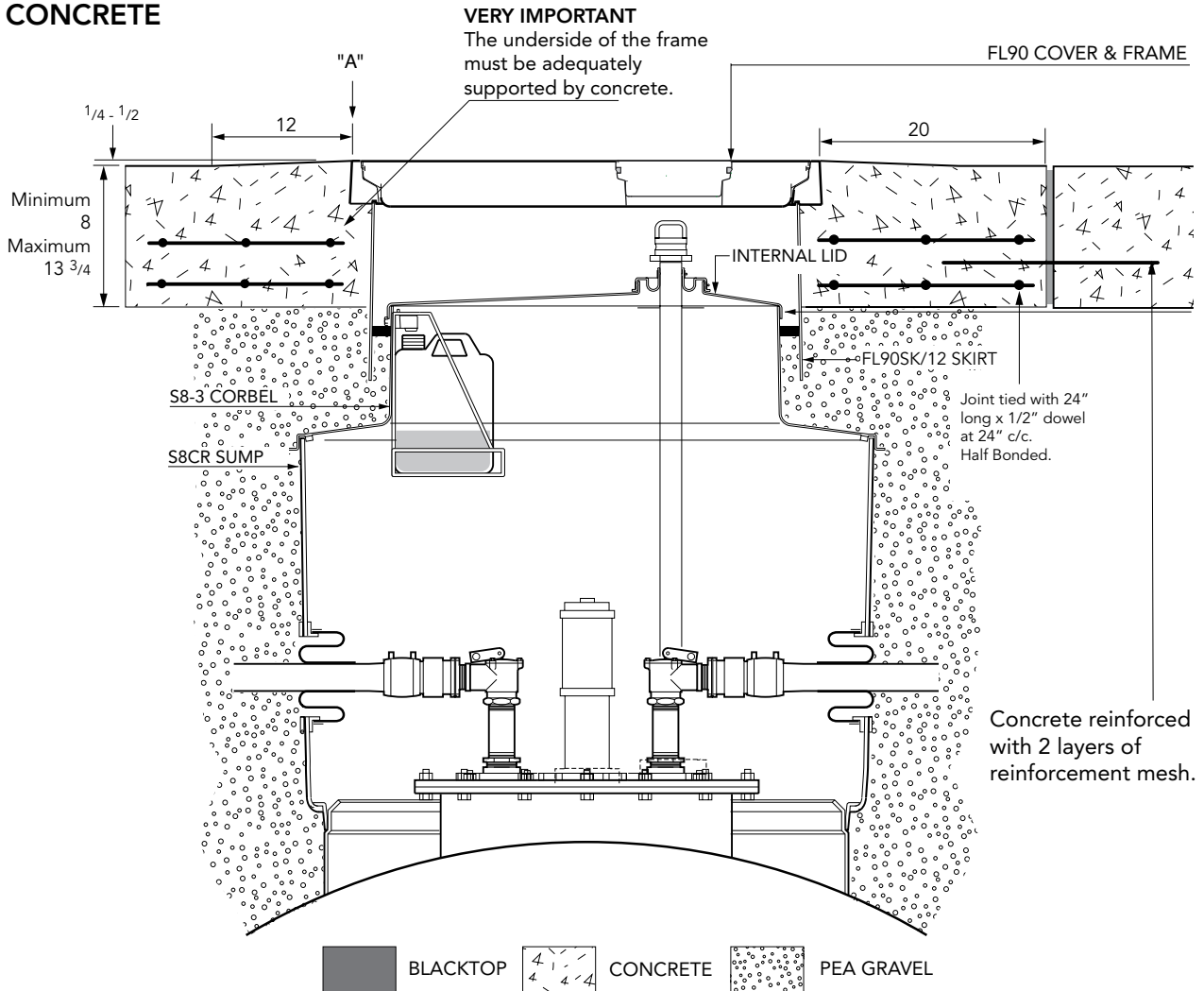

ALTERNATIVE INSTALLATION ADVICE

BLACKTOP

