

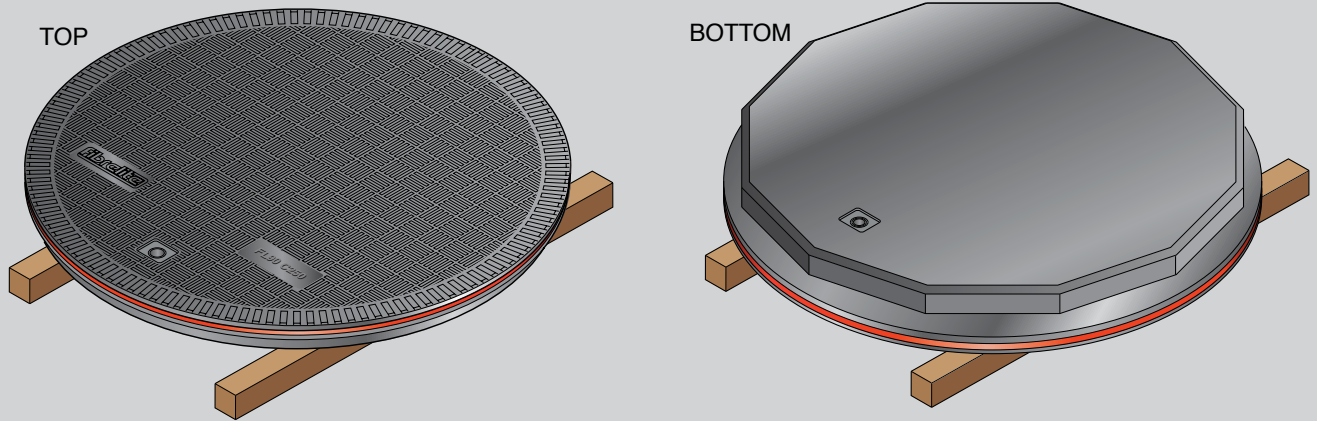

NB: Remove the cover to a safe working area as identified in your risk assessment and cover the open manhole and barrier off. When removing the old key housing, impact safety glasses/goggles and gloves should be worn. When mixing and applying the adhesive, chemically resistant glasses/goggles and gloves should be worn.

Removing the Damaged Key Housing

1



Elevate the cover using wooden blocks to allow the damaged key housing to drop down and protect the cover surface.

2

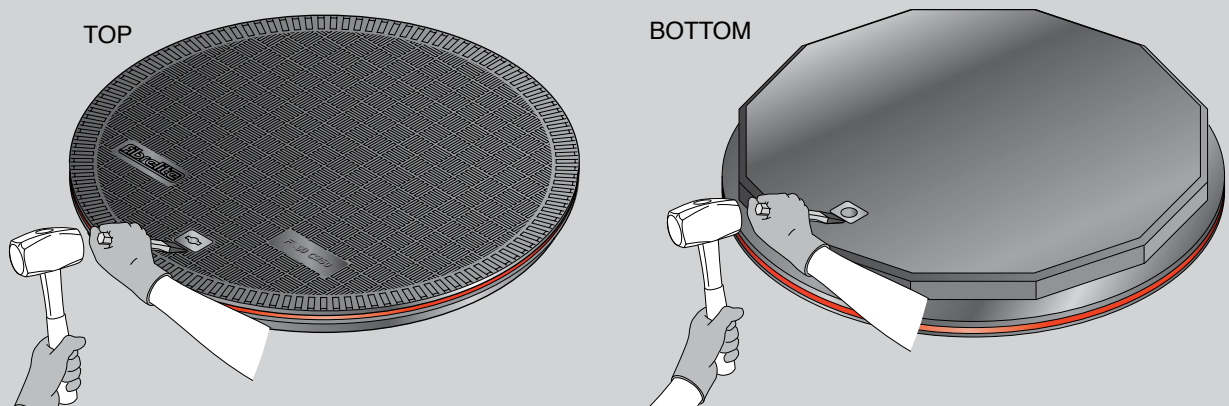

Break either the top or bottom flange of the key-housing away using a cold chisel and hammer

3

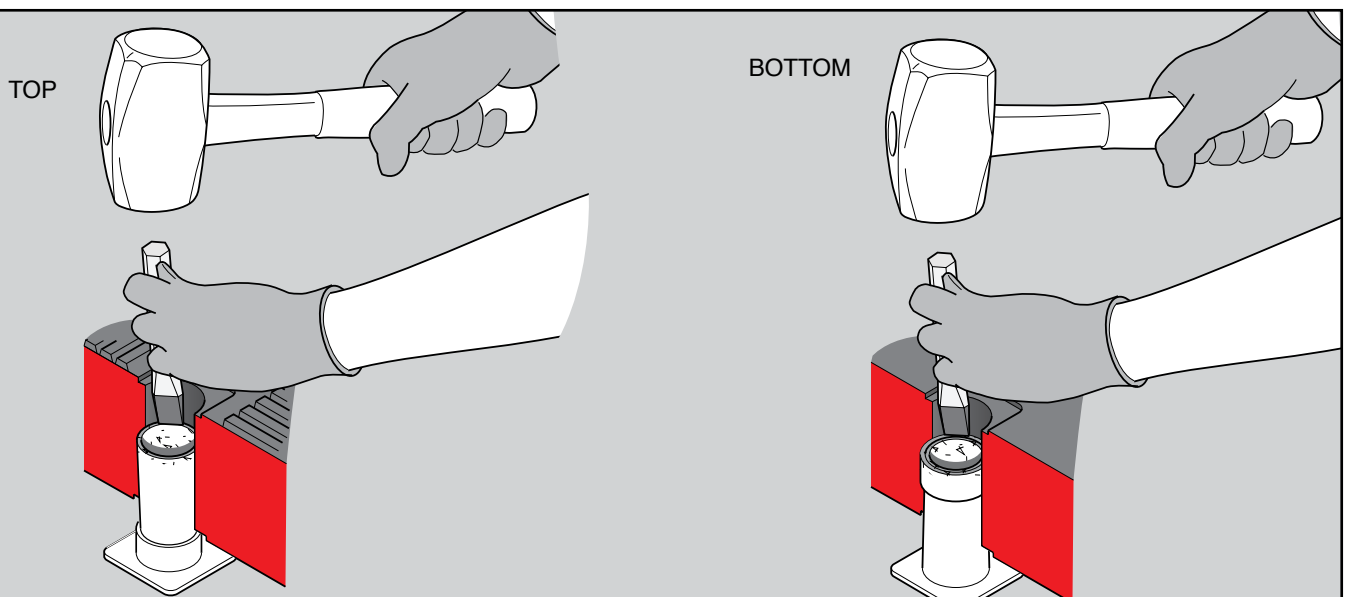

Drive the barrel section and remaining flange out.

Fitting the new Key Housing

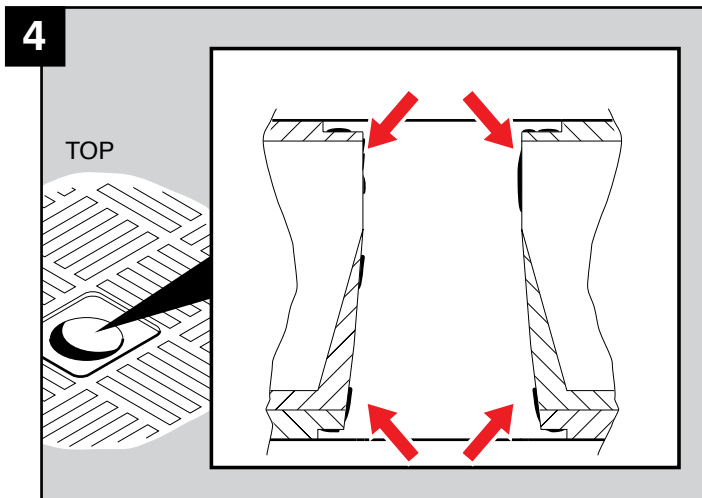

Remove the original adhesive and thoroughly clean the cover flange recesses (top & bottom) and the key housing accommodation hole.

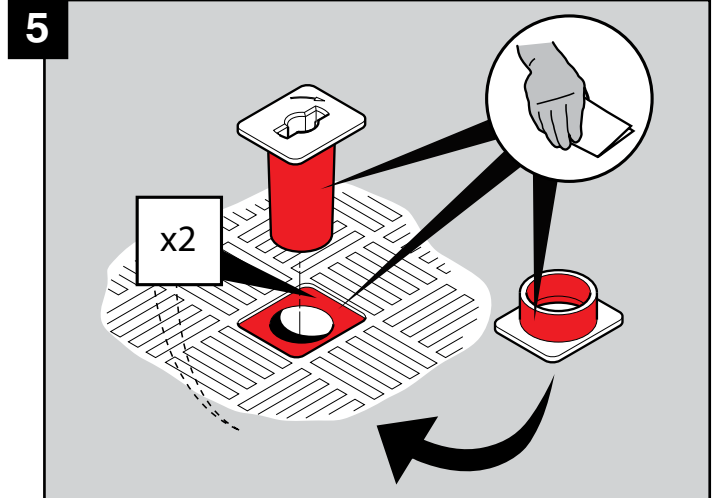

Using the sand paper, abrade the contact surfaces of the key housing and retainer. Also abrade the cover flange recesses.



After mixing, ensure that the adhesive is used within the time shown below for 'Usable life'.

NOTE: The cure speed of 2 part epoxy resins is generally affected by the ambient temperature. A fall of 8°C will roughly double the cure time; a rise of 8°C will tend to halve it.

Typical Performance

Cure Speed	Usable Life	Handling Strength	Working Strength	Full Strength
at 23°C	2 hours	8 hours	24 hours	72 hours

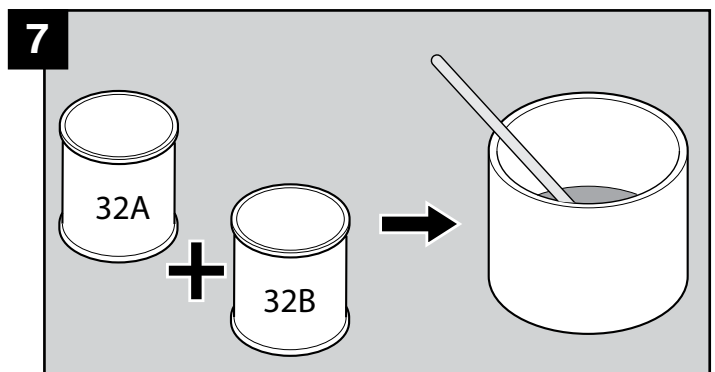

Mix the Resin (32A) and the Hardener (32B) components together in the correct ratio until a uniform Grey colour is achieved. This is the adhesive compound.

Resin Hardener Mixing Ratio

Mix Ratio	(32A) Resin	(32B) Hardener
By Weight	5	4
By Volume	1	1

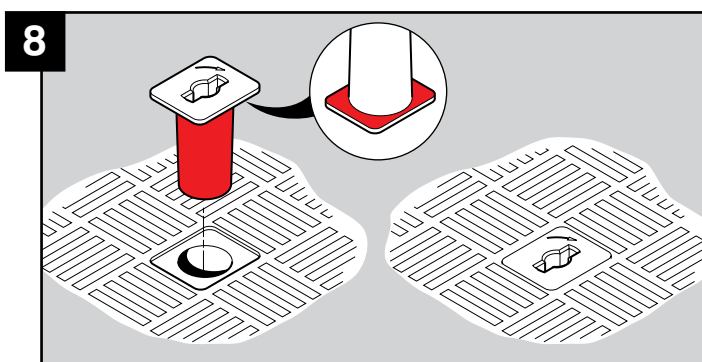

Apply a continuous film of adhesive to the contact surfaces of the key housing. Insert the key housing into the cover, locating the key housing flange in the cover top flange recess.

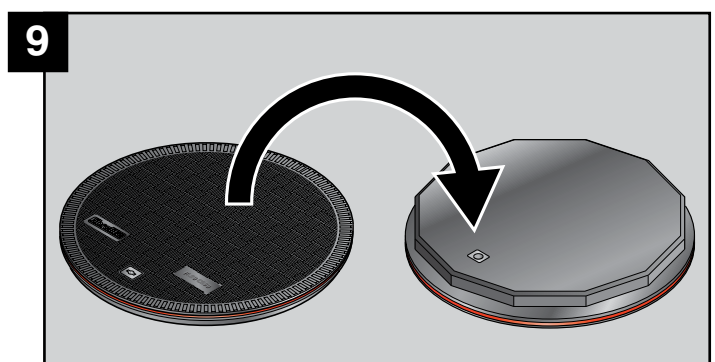

Turn the cover over.

10

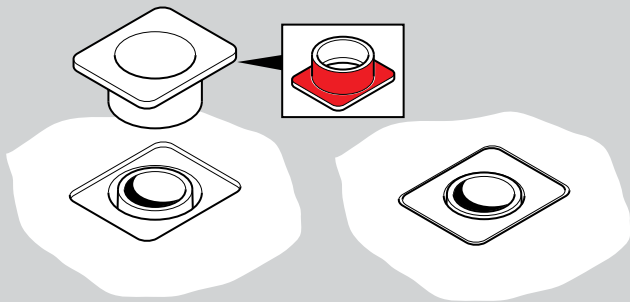

Apply a continuous film of adhesive to the contact surfaces of the retainer. Locate the retainer ring over the key housing. Push the retainer into position until the flange locates into the cover flange recess - ensure the retainer is fully home.

11

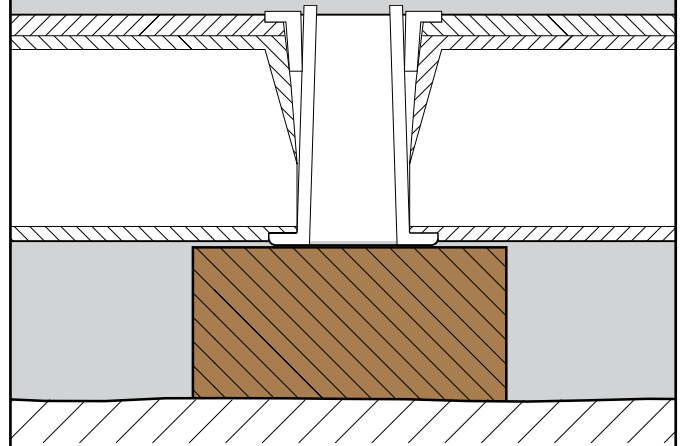

Ensure the key housing flange is supported on a solid surface for the next operation.

12

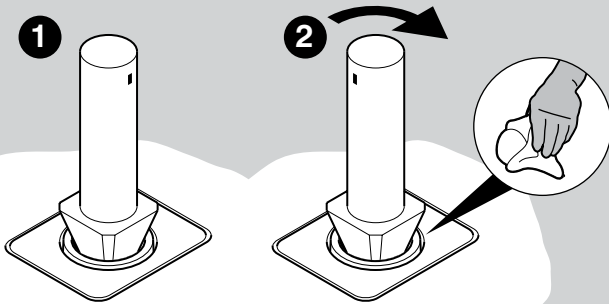

Insert the Swaging Punch into the bore of the retainer and strike with hammer; turn the Swaging Punch through approx 45° and strike again to achieve an additional mechanical bond. Remove excessive adhesive.

Note: caution should be exercised when swaging the retainer to ensure no cracking of the retainer occurs.

13

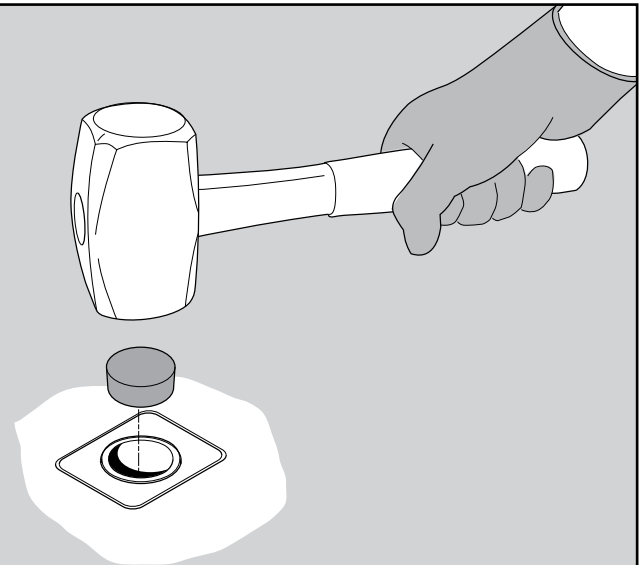

Drive the bung into the key housing bore until it engages on the taper.

14

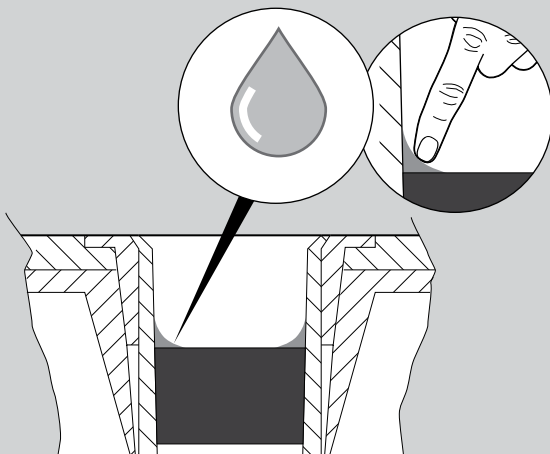

Apply a bead of 40FC sealant to the edge of bung and smooth over to seal.